

# Radio-<sup>IND</sup>Electronics<sup>®</sup>

60c ■ JUNE 1973

FOR MEN WITH IDEAS IN ELECTRONICS

**LEONARD FELDMAN TELLS  
How SQ Logic Works**

**TEST IC's 11 WAYS  
With Your Vtvm**

**VIDEO TAPE RECORDERS  
Where They Stand Today**

**PHONE SENTRY  
Build It For \$30**

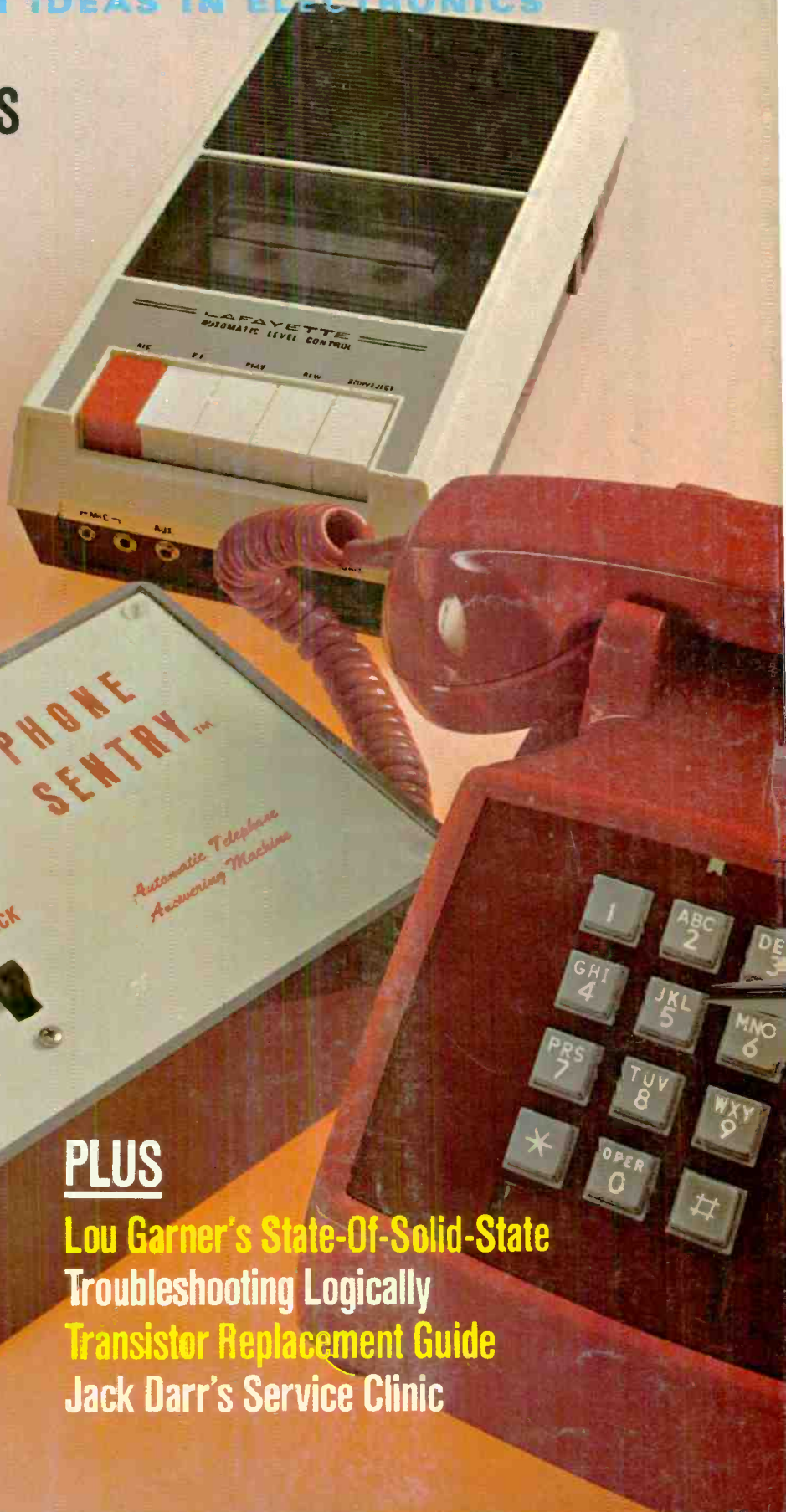

**PLUS**

**Lou Garner's State-Of-Solid-State  
Troubleshooting Logically  
Transistor Replacement Guide  
Jack Darr's Service Clinic**

A  
**GERNSBACK**  
PUBLICATION



## As you can see, your Sylvania distributor has 200 picture tubes in stock.

And they're all in just five Sylvania cartons.

Because our line of five color bright 85XR® OEM-quality tubes gives maximum coverage of 19V, 21V, and 25V diagonal sets with a minimum of stock.\*

It also means faster service because these Sylvania picture tubes are direct replacements. You replace a kimcode with a kimcode, a bonded with a bonded.

And then, there is the biggest advantage of all: You can count all your large-screen color tube needs on the fingers of one hand.

See your local GTE Sylvania distributor for a complete replacement list. With needs that you

can count on one hand, you can bet he has the tube you want in his hands.

Sylvania Electronic Components, 100 First Ave., Waltham, Mass. 02154.

- \*XR23VANP22/
- SRE25BGP22 . . . . . Replaces 53 types
- XR23VAQP22/
- SRE25BHP22 . . . . . Replaces 27 types
- XR19VABP22 . . . . . Replaces 22 types
- XR18VAHP22 . . . . . Replaces 82 types
- XR18VADP22 . . . . . Replaces 16 types

**GTE SYLVANIA**

If you've ever said...

# "There must be a better way to earn a living.."

one of our free Career Guidance Booklets may provide the opportunity you've been looking for.

It happens to all of us, sooner or later. No matter what kind of job we have.

One day, it suddenly strikes home that—like it or not—we're going to have to work for a living, the rest of our lives. And most of us are horrified at the thought of forever being locked into the jobs we now hold.

"Surely," we tell ourselves, "there must be a way to earn enough extra dollars each month to balance the family budget. Surely, there must be a way to get the kind of position where you don't have to worry about job security. Surely, there must be a way to get a job that offers greater opportunity for advancement, and more job satisfaction."

"Surely," in other words, "there must be a better way to earn a living!"

If you, too, have been thinking these thoughts lately, you'll find one of our free Career Guidance Booklets very helpful at this time. We invite you to send for one.

Your free booklet will describe the opportunities for higher income and greater job security you might



expect in one of the career fields listed on the coupon below. It will also explain why ICS can prepare you for this new career field... right in your own home... in your spare time... *regardless of your education or past experience.*

In addition, you will receive a free "Demonstration Lesson" that lets you see for yourself why preparing for a more rewarding career—the ICS way—may be a lot easier than you think.

Please bear in mind, as you check off your career choice on the coupon below, that ICS has a long and distinguished record of success as a career training organization. In fact, more than 8,500,000 men and women have turned to ICS for career training, since 1891.

ICS has provided training programs for various divisions and branches of companies like Ford; U.S. Steel; Chrysler; Mobil; DuPont; etc.

ICS Career Training is approved for Veterans and Servicemen under the new G.I. Bill, and is Accredited by the Accrediting Commission of the National Home Study Council.

In short, ICS training methods are valued and respected not only by ICS graduates...but also by leaders in Business, Industry, Government, and Education.

Now it's your turn to discover how ICS training can start you in a rewarding new profession. Just fill in the coupon below and mail it today for your free Career Guidance Booklet and free "Demonstration Lesson."

**Keep this certificate when you mail the coupon for your free Career Guidance Booklet and "Demonstration Lesson"**

This certificate symbolizes the long and distinguished record of success that ICS has enjoyed as a Career Training Institute. It is your assurance that ICS stands ready to serve you, just as it is serving individuals, business and industry of the world.

**ICS** International Correspondence Schools  
Scranton, Pennsylvania 18515 XA638X

Please send me a free Career Guidance Booklet, and a free "Demonstration Lesson" for the field I have checked. I understand I am under no obligation.

<input type="checkbox"/> Accounting	<input type="checkbox"/> Communications/ Broadcasting/Elec- tronics Specialist	<input type="checkbox"/> FCC Licensing	<input type="checkbox"/> Restaurant/Club Management
<input type="checkbox"/> Air Conditioning/ Refrigeration & Heating	<input type="checkbox"/> Drafting	<input type="checkbox"/> Hotel/Motel Management	<input type="checkbox"/> TV Repair and Servicing
<input type="checkbox"/> Airline/Travel	<input type="checkbox"/> Electrician	<input type="checkbox"/> Income Tax Specialist	<input type="checkbox"/> High School Division (For students who want to earn a High School Diploma.)
<input type="checkbox"/> Automotive Mechanics	<input type="checkbox"/> Electronics Technician	<input type="checkbox"/> Interior Decorat- ing and Design	
<input type="checkbox"/> Business Management	<input type="checkbox"/> Engineering	<input type="checkbox"/> Production Management	
<input type="checkbox"/> CATV/MATV Electronics Specialist	<input type="checkbox"/> Check here for special information if age 16, or under,		
<input type="checkbox"/> Computer Programming			
<input type="checkbox"/> Computer Servicing			

Name \_\_\_\_\_ Age \_\_\_\_\_  
Address \_\_\_\_\_ Apt. no. \_\_\_\_\_  
City \_\_\_\_\_ State \_\_\_\_\_ Zip \_\_\_\_\_

Approved for Veterans' Training. Eligible Institution under the Guaranteed Student Loan Program. Accredited Member National Home Study Council. Canadian residents use coupon address for service from ICS Canadian, Ltd. In Hawaii: 931 University Ave., Honolulu, Hawaii 96814

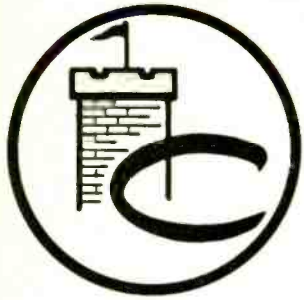

# The Tuner People

*Pioneers of TV Tuner Overhauling  
Originators of Complete TV Tuner Service*

*Castle offers the following services to solve ALL your television tuner problems.*

## Universal Replacements from \$8.95

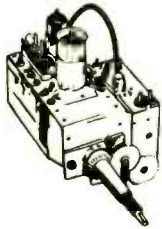

These universal replacement tuners are all equipped with memory fine tuning and uhf position with plug input for uhf tuner. They come complete with hardware and component kit to adapt for use in thousands of popular TV receivers.

STOCK No.	HEATERS	SHAFT		I.F. Snd.	PRICE
		Min.*	Max.*		
CR6P	Parallel 6.3v	1 3/4"	3"	41.25	8.95
CR7S	Series 600mA	1 3/4"	3"	41.25	9.50
CR9S	Series 450mA	1 3/4"	3"	41.25	9.50
CR6XL	Parallel 6.3v	2 1/2"	12"	41.25	10.45
CR7XL	Series 600mA	2 1/2"	12"	41.25	11.00
CR9XL	Series 450mA	2 1/2"	12"	41.25	11.00

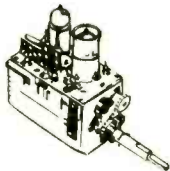
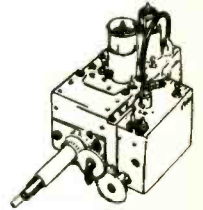

## Castle Replacements \$15.95

Castle custom replacements made to fit in place of original tuner. Purchase outright . . . no exchange needed. Write for current list of Castle replacements, or request the part number you require (use number on ORIGINAL TUNER ONLY; do not use service literature numbers). Available for many of the popular models of following manufacturers: Admiral, Curtis Mathes, Emerson, GE, Heathkit, Magnavox, Motorola, Muntz, Philco, RCA, Sears, Sylvania, Westinghouse, Zenith and many private labels.

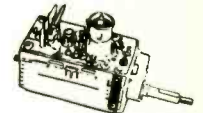

## Tandem uhf-vhf replacements NOW \$21.95

Available in popular models of: Muntz, Olympic, Philco, Sears, Westinghouse and private labels.



## Overhaul Service \$9.95

*This is the service pioneered by Castle! We are now in our third decade of serving the TV Service Industry*

Service on all makes and models, vhf or uhf, including transistor and color tuners . . . one price \$9.95 (does not include tuners older than 10 years). Overhaul includes parts, except tubes and transistors.

Simply send us the defective tuner complete; include tubes, shield cover and any damaged parts with model number and complaint. Your tuner will be expertly overhauled and returned promptly, performance restored, aligned to original standards and warranted for 90 days.

Dismantle tandem uhf and vhf tuners and send in defective unit only. Remove all accessories . . . or dismantling charge may apply.

## Custom Exchange Service \$17.95

When our inspection reveals that original tuner is unfit for overhaul, and it is not available from our stock of outright replacements, we offer to make a custom replacement on exchange basis. Charge for this service is \$15.95 for uhf tuner and \$17.95 for vhf tuner.

If custom replacement cannot be made we will custom rebuild the original tuner at the exchange replacement price.

All replacements are new or rebuilt. All prices are f.o.b. our plant. Add shipping and handling of \$1.25 on all prepaid orders. We will ship C.O.D.

## CASTLE TV TUNER SERVICE, INC.

5715 N. Western Ave., Chicago, Ill. 60645 • Ph. 312-561-6354

Circle 2 on reader service card

# Radio-Electronics

FOR MEN WITH IDEAS IN ELECTRONICS

More than 65 years of electronics publishing

JUNE 1973

## SPECIAL FEATURES

- 38 **VTR's—Many Different Systems**  
Home video recording is just around the corner. Compare the existing systems. *by Fred Petras*
- 53 **Video Cassettes—Everything You Wanted To Know**  
The ¾-inch video cassette and how it works.  
*by Alfred Zuckerman*

## BUILD ONE OF THESE

- 35 **Phone-Sentry Takes Your Calls**  
Add two plug-in cassette tape recorders to complete the system. *by Roger L. Smith*
- 56 **Electronic Music Synthesizer**  
Part II—Build the controller electronics.  
*by John Simonton, Jr.*

## 4-CHANNEL SOUND

- 44 **How SQ Logic Works**  
R-E's Contributing High-Fidelity Editor takes a close look at how the SQ logic system functions.  
*by Leonard Feldman*

## TELEVISION

- 48 **Troubleshooting Logically**  
Part III—Speed servicing technique you'll want to know about. *by Jon Turino*
- 58 **Step-By-Step Troubleshooting**  
Inside modular TV. *by Art Margolis*
- 67 **Service Clinic**  
Replacement parts. *by Jack Darr*
- 68 **Reader Questions**  
R-E's Service Editor solves reader problems.

## TEST EQUIPMENT

- 42 **11 Ways To Test IC's With A VTVM**  
Easy to make tests that tell you when an IC is bad.  
*by Robert G. Middleton*

## GENERAL ELECTRONICS

- 4 **Looking Ahead**  
Tomorrow's news today. *by David Lachenbruch*
- 26 **Equipment Report**  
Electrix Electrical Kit
- 50 **State-Of-Solid-State**  
New method of FM detection leads off this month's article. *by Lou Garner*
- 60 **R-E's Guide For Substitution Transistors**  
Part IV—220 more types are listed—2N684 thru 2N958.  
*compiled by Robert and Elizabeth Scott*
- 90 **Appliance Clinic**  
Electric heaters. *by Jack Darr*

## DEPARTMENTS

- |                           |                               |
|---------------------------|-------------------------------|
| 93 <b>Books</b>           | 92 <b>Next Month</b>          |
| 16 <b>Letters</b>         | 99 <b>Noteworthy Circuits</b> |
| 6 <b>New &amp; Timely</b> | 107 <b>Reader Service</b>     |
| 89 <b>New Literature</b>  | 98 <b>Try This</b>            |
| 84 <b>New Products</b>    |                               |



**SQ DECODER** is made by Sony. Do you know how it works? . . . . turn to page 44



**VIDEOTAPE CARTRIDGE** machine from Panasonic is one of many entries in the great home videotape race. . . . turn to page 38

Hugo Gernsback (1884-1967)  
founder  
M. Harvey Gernsback, editor-in-chief  
and publisher  
Larry Steckler, CET, editor  
Robert F. Scott, W2PWG CET, technical editor  
Jack Darr, CET, service editor  
Louis E. Garner, Jr., semiconductor editor  
I. Queen, editorial associate  
Leonard Feldman, contributing high-fidelity editor  
David Lachenbruch, contributing editor  
Vincent P. Cicienia, production manager  
Nancy Gipson, production assistant  
H. Matysko, circulation

Cover photograph by Walter Herstatt  
Cover design by Louis E. Rubsamen

Radio-Electronics is indexed in *Applied Science & Technology Index and Readers Guide to Periodical Literature.*



Radio-Electronics, June 1973, Vol. 44, No. 6. Published monthly by Gernsback Publications, Inc., 200 Park Avenue South, New York City 10003. Second-class postage paid at New York, N. Y. and additional mailing office. One-year subscription rate: U.S.A., U.S. possessions and Canada, \$7; Pan-American countries, \$8; Other countries, \$8.50. Single copies 60¢. ©1973 by Gernsback Publications, Inc. All rights reserved. Printed in U.S.A.

**Subscription Service:** Mail all subscription orders, changes, correspondence and Postmaster Notices of undelivered copies (Form 3579) to Radio-Electronics Subscription Service, Boulder, Colorado 80302.

A stamped self-addressed envelope must accompany all submitted manuscripts and/or artwork or photographs if their return is desired should they be rejected. We disclaim any responsibility for the loss or damage of manuscripts and/or artwork or photographs while in our possession or otherwise.

As a service to readers, Radio-Electronics publishes available plans or information relating to newsworthy products, techniques and scientific and technological developments. Because of possible variances in the quality and condition of materials and workmanship used by readers, Radio-Electronics disclaims any responsibility for the safe and proper functioning of reader-built projects based upon or from plans or information published in this magazine.

# looking ahead

## Spain going PAL

MADRID—Although Spanish government sources continue to insist that it's still a wide open race between the German PAL and the French SECAM color systems, we have learned authoritatively that the decision has already been made to go along with Europe's majority in selecting PAL as the official Spanish color transmission system.

After Italy, Spain is the largest West European country still in the black-and-white age. Italy has broadcast experimentally in both PAL and SECAM systems. Spain is currently conducting test broadcasts in PAL. Spain's choice of the PAL system will leave France as the single major West European nation using SECAM. France had held out economic enticements to induce Spain to adopt its system, as it is doing in both Italy and Greece. Because Spain is a "bridge" between France and the North African countries (many of which have selected SECAM but are still broadcasting in black-and-white), Spain's choice of PAL—although not at all unexpected—will come as a bitter blow to French prestige.

Spain, with two networks (vhf and uhf) and 32 TV stations feeding some 5,000,000 TV sets, will take its time in officially inaugurating color broadcasting. It's scheduled now for early 1975. But the government-operated Television Espanola (TVE) which owns all the stations and puts on all programs, has had years of experience in color TV work—for other countries. TVE operates one of Europe's major color standard converters, used in the Olympic games and other major worldwide TV transmissions to change PAL to NTSC color. TVE produces taped

programs in NTSC color for broadcast in Mexico.

## 50-channel cable

A new hotel and convention center in Zurich, Switzerland, gives hotel guests as well as conventioners a choice of 50 channels of color television. Both guest rooms and meeting halls can dial a wide variety of technical, commercial, educational and other programs, as well as regular television programs. The system, developed by Rediffusion Ltd., uses 50 Philips color videotape cartridge players.

## Profusion of brands

As in TV's pioneering days in America, there's a bewildering variety of television brands available in Spain. Because of a strict import quota system, almost all are made in Spain. Many of the brand names, however, are familiar because of technical and/or ownership alliances between Spanish and foreign firms. An American sees such familiar makes as Zenith, Emerson and GE (called "GEE" for General Electrica Espanola), Sony and Sanyo. The ever-present Philips and Telefunken are among the best-selling brands, as are some 100% Spanish makes, such as Vanguard, Inter, Iberia and Elbe. The number of manufacturers has declined from more than 100 to perhaps 25, due to the increasing saturation of the black-and-white market.

Without color, monochrome television has reached a maximum degree of sophistication in Spain. Most large-screen sets (19 and 23 inches) have electronic varactor tuning and many are all-solid-state. There are few truly unique television products on the

market here, however. One is a 23-inch battery-powered receiver by Elbe, its circuitry composed of five solid-state modules. Just the thing to take with you on a picnic when you don't want to miss the bullfight in big-screen living black-and-white.

## Glass cables coming?

The promise of fiber optics—whose commercial uses up to now have been confined largely to gimmicky—may soon be realized, on the basis of development work being carried on in widely scattered laboratories around the globe. The use of a light beam to transmit messages through a glass cable theoretically could move 100 billion bits of information per second, as compared with 100 million for a coaxial cable or microwave relay system.

The problem so far has been energy loss, or leakage, which originally came to 1,600 dB per mile. New developments have reduced this leakage to as low as 6.5 dB, well below the figure required for successful long-distance transmission. There are still many problems—such as the method of modulation and the light source. One straightforward system envisions a simple and conventional light provided by one or more semiconductor diodes. Another would use a laser as a light source.

Among the advantages of fiber-optics transmission: (1) Glass is not affected by moisture or temperature. (2) Being an excellent insulator, glass would be unaffected by stray electrical fields; since modulated light is used, the system would be impervious to magnetic disturbances. (3) Glass cables could be routed through existing underground cable conduits, increasing

their capacity by hundreds of times.

## 4-year warranty

The honors (or whatever you call them) for the longest television warranty probably go to Curtis Mathes. Applying to 19-, 23- and 25-inch modular solid-state color sets, the policy now being tested covers all components except the picture tube (which carries a two-year full warranty and six additional years of pro-rated warranty). Although there is no labor covered by the warranty, the manufacturer believes that most repairs will involve merely the exchange of one of the 14 modules in the set. Defective modules are returned by the technician to the factory for rebuilding.

## Move TV upstairs?

First there was vhf, then uhf. Will it soon be time to start a new television service-way, way upstairs in the GHz bands. One proposal by a member of the White House Office of Telecommunications Policy's Frequency Management Advisory Council suggests that perhaps it will. A. James Ebel, president of KOLN-TV, Lincoln, Neb., envisioned to his conferees a new hi-fi TV system with greater definition, truer color, stereo sound, and perhaps a 3-D picture. For this, a 20 to 25 MHz bandwidth would be required, he reasoned, and therefore stations would have to be moved far higher on the spectrum. To avoid dislocations during the transition period, he suggested that stations also continue to broadcast in lo-fi on their present frequencies.

by DAVID LACHENBRUCH  
CONTRIBUTING EDITOR

# Microfarads never had it so good.



Top-value capacitors all, from the long Mallory line. Each with excellent electrical characteristics, and a choice of leads. Very economically priced. And you can get 'em now, in quantities from a single unit to amounts for any mass-production need.

**PVC epoxy-dipped Mylar® and paper dielectric capacitors.** Long life: 500 hours at 125°C with 50% derated voltage. Excellent moisture resistance. From 100 to 2000 VDC. A wide capacitance range, up to 2 mfd, depending on voltage.

**EPM epoxy-dipped Mylar dielectric capacitors.** Low dissipation factor, good capacity stability, high dielectric strength, small size. Ideal for

radio, TV, general electronics. From 100 to 600 VDC, up to 1 mfd, depending on voltage.

**EWF Mylar-wrap, epoxy-end-filled capacitors.** Mylar dielectric provides high insulation resistance, good moisture resistance, excellent electrical parameters, low dissipation factor, miniature case sizes. Great for coupling and by-pass applications. From 160 to 630 VDC, to .47 mfd, depending on voltage.

**SX polystyrene capacitors.** Exceptionally high insulation resistance, very low power factors. Use them where the utmost in stability versus temperature and time is needed. From 0 to 600 VDC, up to .47 mfd, depending on voltage.

Write for literature, or see your authorized Mallory Distributor.

**MALLORY**

**MALLORY DISTRIBUTOR PRODUCTS COMPANY**

a division of P. R. MALLORY & CO. INC.

Box 1284, Indianapolis, Indiana 46206; Telephone: 317-636-5353

Batteries Capacitors Controls • CRIME ALERT® • DURATAPE® • Resistors • Semiconductors • SONALERT® • Switches • Timers • Vibrators

®Registered Trademark E. I. du Pont de Nemours & Co., Inc.

Circle 3 on reader service card

JUNE 1973 • RADIO-ELECTRONICS 5

# new & timely

## Foil electrets miniaturize pushbutton phone "dials"

A new experimental dialing mechanism that uses less than half the space of the present one is being tested by Bell Labs scientists at Murray Hill, NJ. Instead of the electromechanical switch of the regular pushbutton mechanism, the new device uses a foil electret, a sheet of plastic about a thousandth of an inch thick, which carries a permanent electrical charge or high voltage between its opposite surfaces.

(This permanent electric field is comparable to the magnetic field of a permanent magnet, and the electret has been called the electrostatic analog of the magnet.)

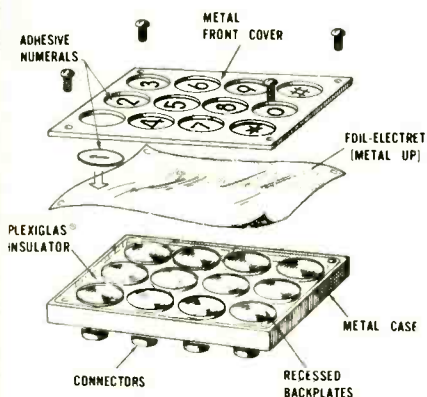

**ELECTRET DIALING DEVICE** has a foil electret sandwiched between the metal front cover and twelve recessed conductive backplate contacts.

The foil, metal-coated on one side, is stretched over a "backplate" of 12 separate conductors. It is covered with a metal cover having twelve apertures in the same positions as the buttons on the pushbutton mechanism. Depressing the foil through any of these apertures moves it nearer the conductor directly behind it, causing a current to flow in the circuitry.

The action is practically identical with that of a "condenser" microphone, except that the change in proximity and resultant flow of charges through the circuit is brought about by finger pressure instead of by sound pressure. (Microphones are now made with foil electrets, which carry their own polarizing charge, making a high-potential supply for the microphone unnecessary.)

The foil is protected by flexible plastic discs, on which the numbers are printed. The pushbutton switch assembly

is only about one-eighth inch thick.

If the new dialing mechanism proves suitable for mass use, it can not only make telephone handsets more compact, but may be cheaper to manufacture. The principle may even be extended to replace keyboard mechanisms in typewriters, computer terminals and other keyboard-operated equipment.

## Computerized metal detector makes plane trips safer

A new type of weapons detector ignores harmless objects like buckles, keys and cigarette lighters, but sounds an alarm when a person is carrying a weapon. Already installed at eight major airports, one hundred have been built under contract from the Federal Aviation Administration by Westinghouse Electric Corp.

The new gun detector is unlike conventional types, which work on the magnetometer principle, simply sensing disturbances in the earth's magnetic field. It is an active device, that generates two electromagnetic fields at different frequencies, one high and one low, in three planes within the passageway. No matter where or how the weapon is carried it is certain to be detected, according to Westinghouse spokesman R. W. Esary. "The console of the detector has data processing circuitry," he said, "that analyzes disturbances in the fields with a high degree of accuracy. This gives us

the selectivity that cuts down on false alarms."

## Laser and computer teamed for air pollution quick-test

A new and quick method of detecting gas concentrations in air has been developed by Bell Labs scientist Lloyd B. Kreuzer. His method is based on modifications of ordinary gas spectroscopy, which operates on the principle that different gases absorb light at different frequencies. Thus one gas may have a strong "absorption band" near the red end of the spectrum, another in the green.

A sample of the air to be analyzed is held in a specially designed absorption cell, and a laser beam directed into the cell. If the pollutant gas is one that absorbs energy at the frequency (wavelength) of the laser light, the temperature and air pressure in the cell rise in direct proportion to the quantity of gas in the air.

Changes in pressure are registered by a microphone in the cell, and the resultant electric signal is fed into the computer, which identifies the pollutant and records its quantity. The computer also "tunes" the laser, sending various frequencies of light into the absorption cell to detect different types of pollutants. The computer can handle up to about 20 different gases simultaneously.

*(continued on page 12)*



**AIRLINE PASSENGER** clears new Westinghouse Electric gun-probe tunnel.



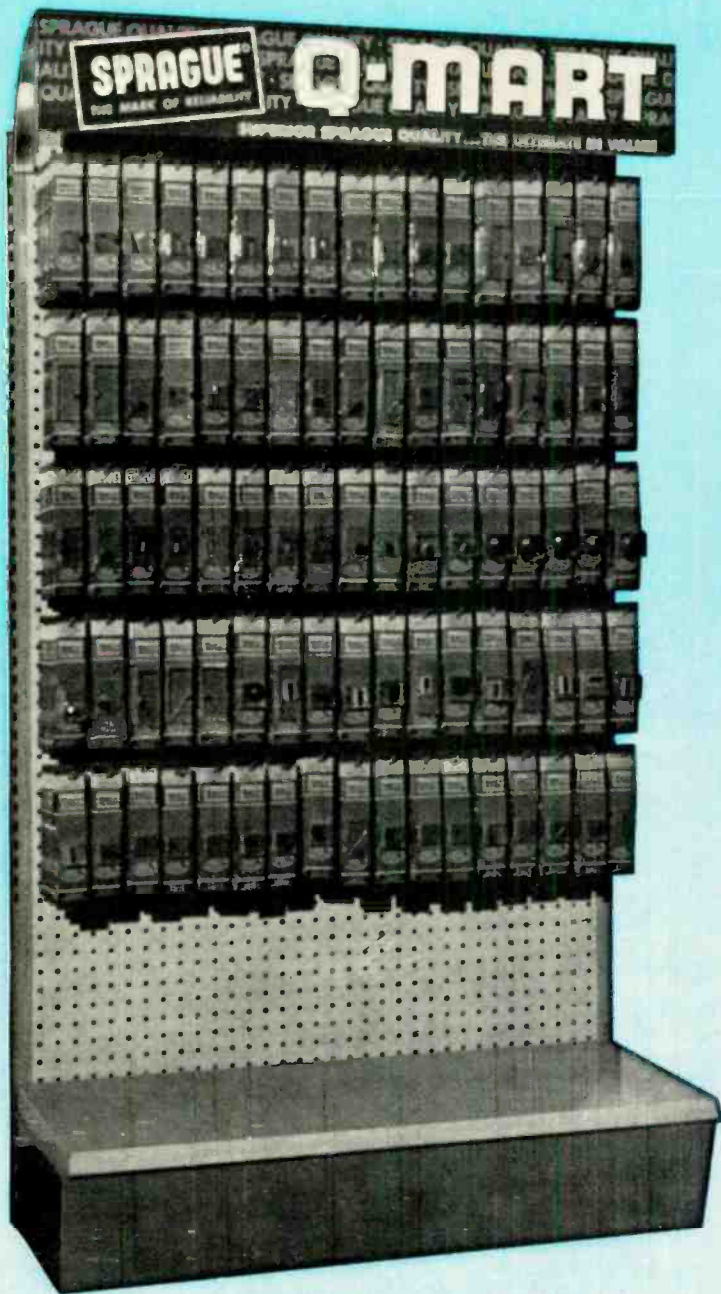

**Don't delay . . . Stop at your Sprague distributor's Q-MART today! And while you're there, don't forget to pick up your free copy of Sprague's 48-page Semiconductor Replacement Manual K-500. Or . . . write to Sprague Products Co., 81 Marshall St., North Adams, Mass. 01247.**



**THE BROAD-LINE PRODUCER OF ELECTRONIC PARTS**

*New*  
**SPRAGUE  
 SEMICONDUCTOR  
 Q-MART READY  
 TO SERVE YOU!**

**Replacement Semiconductors for  
 Service Technicians, Laboratories,  
 Hobbyists, Experimenters**

Sprague's "Total-Capability" Replacement Semiconductor Q-MART, being installed in more distributors' stores with each passing day, simplifies the selection and purchase of small-signal transistors, power transistors, field effect transistors, silicon rectifiers, linear integrated circuits, and LED devices, with a product variety that cannot be obtained from any other single source.

Designed with the service technician/hobbyist/experimenter in mind, it gives you ready replacements for over 30,000 original manufacturers' part numbers which are frequently found in home/mobile entertainment and communications equipment.

You'll enjoy the ease with which you can serve yourself right from your Sprague distributor's Q-MART. Every semiconductor is individually packaged in a handy, reusable Klear-Pak® plastic box (no hard-to-open bubble packs or blister packs) mounted on a card that gives you a good description of the device, complete with pinning diagram, electrical parameters, and important cross-reference replacement information.

What's more, every device is a popular device. There are no dogs to waste time with or cause confusion. Your distributor's Q-MART contains only the hottest, fastest-selling semiconductors based on frequency-of-use. With this kind of movement, you can be sure you're always getting factory-fresh stock.

65-2115



Circle 4 on reader service card

# Kit for kit, text for text, dollar for dollar, your best home training buy is NRI

*NRI "hands on" method gives you as much as 2 years of on-the-job experience. Pick your field and enroll now!*

After over 55 years of training men for Electronics in their homes, NRI knows that theory alone is not enough. That's why NRI concentrates so heavily in the development of special training equipment. Your hands must be trained as well as your head, and NRI gives you both kinds of training in a manner no other school can match.

**You get your hands on professional parts** and demonstrate theory you read in NRI's unique "bite-size" texts. You build designed-for-learning Electronic circuits and complete, operating equipment. You use what you build to prove out what you read. Electronics comes alive in the most valuable, practical manner. You experiment with the same kinds of solid-state and transistorized and tube circuits you'll find on the job—not hardware or breadboard hobby kits.

**NRI prepares you for your choice of careers** in Color TV Servicing, Communications, Industrial Electronics and the growing field of Computer Electronics. Many NRI graduates start earning \$5 to \$7 an hour extra soon after they enroll, fixing home Electronic equipment for friends and neighbors in spare time. NRI's remarkable teaching method simplifies, organ-

izes, dramatizes subject matter so that any ambitious man, regardless of his education, can effectively learn and profit from the Electronics course of his choice—and NRI gives you 15 training plans to choose from.

**Over three-quarters of a million** men have enrolled with NRI since 1914. Proof of the value and experience you get when you choose NRI for your Electronics training . . . proof of why NRI continues to be the country's largest Electronics home-study school. Discover for yourself how easy it is to move into Electronics and move up in a rewarding career. Mail the postage-free card for the new NRI Catalog. There is no obligation. No salesman will call on you because NRI does not employ salesmen. NATIONAL RADIO INSTITUTE, Washington, D.C. 20016.



If postage-free card is missing, write to:  
**NATIONAL RADIO INSTITUTE**  
Washington, D.C. 20016

#### **GET FACTS ABOUT GI BILL**

If you have served since January 31, 1955, or are in service now, check GI line on postage-free card.

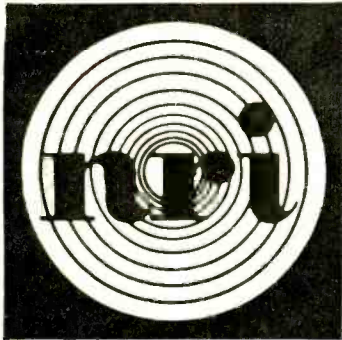

**...first and only school to include training equipment designed from chassis up for your education**

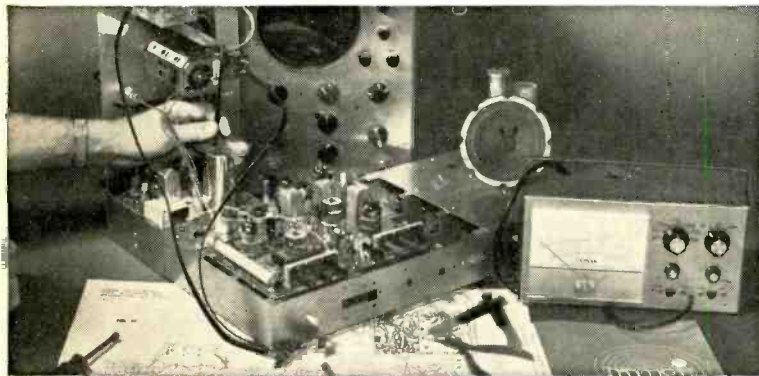

**Earn \$5 to \$7 an hour spare or full time in COLOR TV SERVICING**

It's easy to learn as you build, stage-by-stage, the only custom designed Color TV receiver engineered specifically for training purposes. You grasp a professional understanding of all color circuits through logical demonstrations never before presented. The end product is a superb Color TV set that will give you and your family years of viewing pleasure. NRI gives you the option of selecting either Color or black-and-white training equipment.

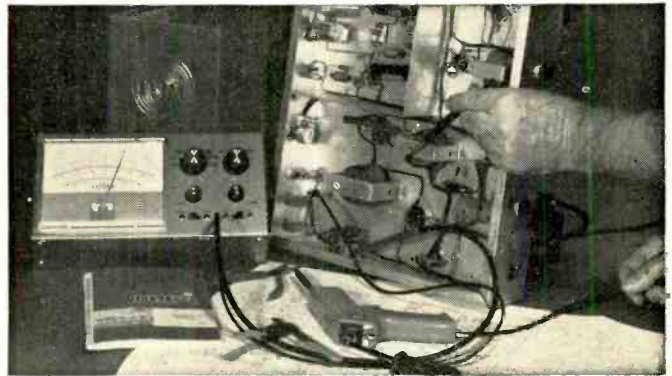

**There's glamour, success awaiting Technicians in COMMUNICATIONS**

NRI gives you the experience you need to qualify for jobs in TV broadcasting stations, or operating and servicing mobile, marine, aviation communications equipment. You build and use a solid-state voltohmmeter; perform experiments on transmission lines and antenna systems, even build your own 25-watt, phone-cw amateur transmitter band. In all NRI Communications courses, *you must pass your FCC exams—or you get your money back.*



**Fill technical jobs without a degree in INDUSTRIAL ELECTRONICS**

NRI's Electronics Technology course gives you completely specialized training kits engineered for business, industrial and military Electronics fields. On completing this training, competent technical ability can be instantly demonstrated by you. As you learn, you actually build and use your own training center in solid-state motor control and analog computer servo-mechanisms. Telemetry circuits, solid-state multi-vibrators, even the latest integrated circuits are included in your home training program.

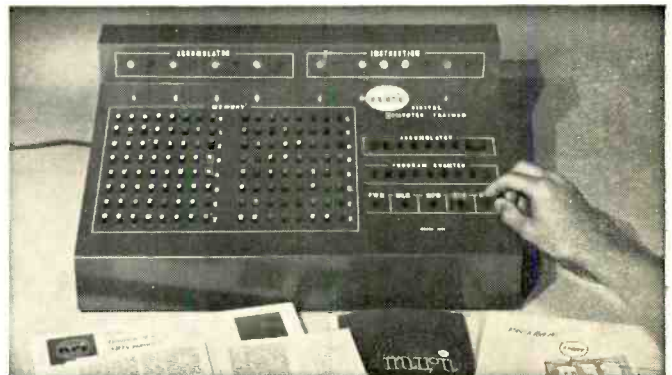

**Prepare quickly for a high pay career in COMPUTER ELECTRONICS**

This may well be the most unique and exciting educational aid ever developed for home training—a digital computer *with memory* you build and use to learn organization, trouble shooting, operation and programming. It performs the same functions as commercial computers you encounter on the job. Lessons stress computer repair. You perform a hundred experiments, build hundreds of circuits. Your own solid-state voltohmmeter is included among the ten training kits you receive.

**OVER 50 YEARS OF LEADERSHIP IN ELECTRONICS TRAINING**

The new system can detect gas concentrations as low as 1 part in 10 billion, a much greater sensitivity than needed in present practical applications. It has the further advantage that it can identify

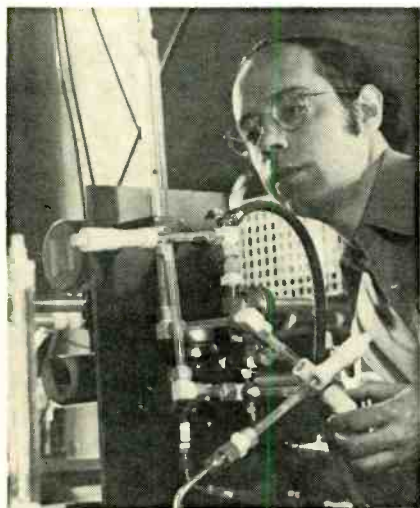

**POLLUTANTS ARE MEASURED** by a blend of spectroscopic, acoustic and electronic techniques in this laser-computer detection system developed by Bell Laboratories.

many kinds of pollutants without changes in instrumentation. Chemical methods of detection often require entirely different set-ups for different pollutants. The new system can also be operated by persons not specially skilled in the particular field.

### **NATESA Executive Council discusses convention, merger**

After hearing convention chairman Nolan B. Boone report on the status of the second annual joint associations convention, the second 1972-73 quarterly meeting of the NATESA Executive Council resolved to hold the NATESA-NEA 1973 convention at the Crown Center Hotel in Kansas City, Mo, August 24-26.

Merger Committee Chairman LeRoy Ragsdale, reporting on the lack of progress by the combined merger committee, stressed a need to steer away from any tendencies toward personality conflicts and from continued dwelling on negative aspects. The Council concurred that positive action toward the goals of merger was the only sensible course. Executive Director Frank Moch reemphasized that he would not hesitate to work for the new Association if a realistic and equitable merger can be effected.

Copies of the by-laws of NEA and NATESA in side-by-side form, with a space between for suggestions and comments, have been sent to service associations by By-Laws Committee Chairman Bob Harrison. He was instructed by the Council to receive the studied suggestions and incorporate the information into a completely drafted by-laws proposal, to be submitted as a composite suggestion to the combined Merger Committee before the convention in August.

### **Long-playing record now 25 years old**

In June 1948, Dr. Peter Goldmark, engineering director of the Columbia Broadcasting System, announced a revolutionary new phonograph record, the long-playing microgroove disc, playing at 33 1/3 revolutions per minute, and recorded with 224 to 300 grooves per inch, instead of the 90 grooves per inch of the (then) standard 78-rpm record. Fidelity equal to—in fact superior to—that of the high-fidelity 78-rpm record of the day was made possible, it was reported, by using a stylus only one-thousandth of an inch in diameter, one-third that of the 78-rpm styli. This stylus, it was said, played with a tracking force of only 1/5 ounce (in today's language, between 5 and 6 grams.).

Up to 50 minutes of playing time could be obtained with a 12-inch microgroove record, as contrasted to the 8 or 9 minutes possible up to that time.



**DOCTOR PETER GOLDMARK**, as he appeared at the announcement of the Columbia LP Microgroove record in 1948.

Goldmark and others made optimistic predictions for the new technique, but nobody imagined the almost complete takeover by the microgroove. The transistor celebrated its 25th birthday a few months ago, but the tube is still with us. But more than one of the youthful modern devotees of high fidelity (or rather hi-fi) has never seen a 78-rpm record, and on being shown one, calls it an "album." Possibly the greatest single factor in bringing about our age of all-pervading recorded music, it opened the way to improved recording and reproducing equipment, stereo, four-channel and all the other features of today's audio scene.

### **L/Cpl Tanguay wins 1973 Hugo Gernsback scholarship**

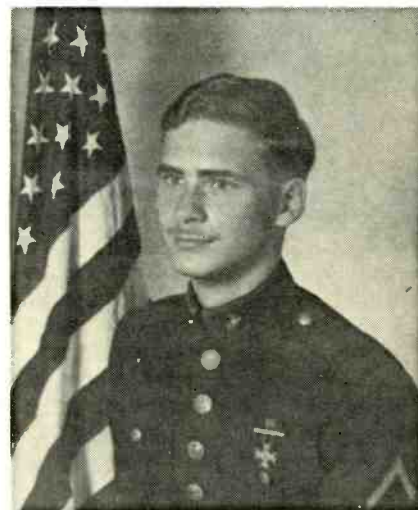

Girard D. Tanguay is one winner of the 1973 Hugo Gernsback Scholarship Award, given annually to an outstanding student in each of nine home-study schools of electronics.

Now 20 years old, Girard was born and brought up in West New York, New Jersey. An Eagle Scout and member of the Order of the Arrow, he also acted as softball scorekeeper for the Town of West New York during the summers of 1969 and 1970. He enlisted for 4 years service with the United States Marine Corps in October, 1971, and is now a Lance-Corporal of the Marines. Enrolling in Career Academy, Milwaukee, Wisc. in October, 1972, he finished all the examinations and experiments by the end of January, 1973, and graduated with an "A" average.

L/Cpl Tanguay hopes that his elec-  
*(continued on page 14)*

# This *Free* sample lesson can start you towards a high-pay career as **ELECTRONICS TECHNICIAN**

## The man needed for today's "world of tomorrow"

Find out how to take the important step from a low-pay, dead-end job to an exciting future in electronics. LaSalle's free sample electronics lesson demonstrates how you can learn at home to earn big money as an electronics technician. Send for this free lesson. There's no obligation.

### Thousands of technicians in demand!

Each year the electronics field continues to grow, revolutionizing industry and communications, developing new applications that reshape our lives. "The world of tomorrow" is here . . . with electronic crime detectors, electronic traffic control, electronic factory automation, electronic medicine . . . and with TV-radio broadcasting reaching new peaks of development. No wonder the electronics technician is the man of the hour — with thousands of high-pay opportunities to choose from! Why don't you get started in this rewarding field?

### Let LaSalle teach you at home

You don't need previous experience for LaSalle training. You learn the basic principles of electronics under the guidance of experienced instructors. Lessons in this up-to-date course are simply presented, easy to understand. You are led step-by-step into practical applications — with emphasis on modern techniques. You actually build your own electronic equipment with parts supplied to you. You receive individual attention and you can have additional help by mail whenever you need it. When you have satisfactorily completed your studies, you are awarded the LaSalle diploma, a respected credential.

### Training for FCC License included

If your goal is in the field of communications you will need the Government FCC (Federal Communications Commission) License. LaSalle training in communications fully prepares you to pass the FCC's first class radio-telephone operator license exam.

LaSalle has enrolled more than 2,000,000 men and women in its many career programs. It gives you a great feeling of confidence to know that your training is in the hands of a leader in home study.

### Send for FREE sample lesson right away

You owe it to yourself to find out how LaSalle can prepare you for a big future in electronics. Mail the coupon today. Send now for your free sample lesson. There's no obligation. LaSalle, 417 South Dearborn Street, Chicago, Illinois 60605.

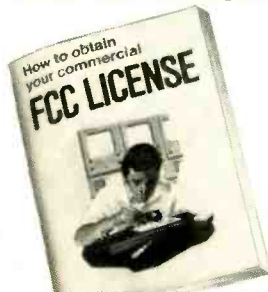

## FREE! Guide for FCC License.

Gives complete information on how to get a Federal Communications Commission license. Sent with your free sample lesson and electronics booklet.



© 1973 LaSalle Extension University.

## MAIL THIS HANDY POSTAGE PAID ENVELOPE

Cut coupon along dotted lines, fill in your name and address . . . fold, seal (tape, paste or staple) and mail. No stamp or envelope is necessary.

Dept. 90-069

**YES,** I want, free of cost or obligation, your sample lesson and also your two illustrated Booklets, "Your Place in the World of Electronics" and "How to Obtain Your Commercial FCC License."

I am especially interested in:

- Instrumentation Electronics       Automation Electronics  
 Communications Electronics       First Class FCC License

Mr. \_\_\_\_\_ Age \_\_\_\_\_  
 Mrs. \_\_\_\_\_  
 Miss \_\_\_\_\_ (Circle title and please print)

Address \_\_\_\_\_ Apt. No. \_\_\_\_\_

City \_\_\_\_\_ State \_\_\_\_\_ Zip \_\_\_\_\_

03B FOLD HERE (DO NOT CUT) SEAL AND MAIL TODAY — NO STAMP NEEDED

FIRST CLASS  
 PERMIT NO. 27  
 CHICAGO, ILL.

BUSINESS REPLY MAIL

No postage stamp required if mailed in the United States

Postage will be paid by

**LA SALLE EXTENSION UNIVERSITY**  
*A Correspondence Institution*  
**417 S. DEARBORN STREET**  
**CHICAGO, ILLINOIS 60605**

Circle 5 on reader service card

# The first NEW amplifier design since



## the ORIGINAL Super Amp

You remember the first super power amplifier - the Crown DC300. Well, most of its competitors are still using those six year old circuit designs pioneered by Crown. Most every amp but Crown's new **DC300A** - a totally redesigned amplifier inside and out. Frankly, the DC300A is not created for the hi fi mass market, but for demanding commercial and professional applications. However, we know there are discerning audiophiles, perhaps like yourself, who can appreciate the difference.

The new DC300A has double the number of output transistors, effectively twice the muscle of the old DC300 for driving multi-speaker systems. Each channel has eight 150-watt devices for 1200 watts of transistor dissipation per channel. Advanced electronic output protection permits the DC300A to drive the toughest speaker loads at higher outputs before going into protection, and even then there are no annoying flyback pulse noises or DC fuses to blow.

The new DC300A has unprecedented signal purity. IM and harmonic distortion ratings are .05%, although typically below .025%. Hum and noise rating is 110dB below 150 watts, while typically -122dB. The difference in increased listening comfort is impressive.

Although totally new, the DC300A has inherited some important traits from its predecessor:

**PRICE** — still under \$700

**WARRANTY** — three years on all parts, labor and round-trip shipping

**POWER RATING** — 150 w/ch continuous at 8 ohms; power at clip-point typically 190 w/ch at 8 ohms, 340 w/ch at 4 ohms, 500 w/ch at 2.5 ohms, or plug in two parts for 600 watts continuous mono power at 8 ohms.

There are many new super-power amplifiers. But when you buy a Crown DC300A, you're buying more than just an amp. You're buying the Crown company — a professional audio equipment manufacturer with a 26-year reputation for solid quality and lasting value. There are thousands of Crown amps in the field still working to their original specifications, and still outperforming most new amps. Visit your Crown dealer to hear the difference. For detailed product data, write Crown International, Box 1000, Elkhart, Indiana, 46514.



# CROWN

Circle 6 on reader service card

# new & timely

(continued from page 12)

tronic knowledge may help him advance in the Marines, and will go into some section of the electronics field—he has not yet determined which—upon his discharge.

### Employment now opening up for engineering technicians

With the economy apparently on an upturn, it appears that there are more openings for engineering technicians than for full-fledged engineers, many of whom are still finding the going very slow. A two-year midwestern college (Scott Community College of Davenport, Iowa) reports that they have had 56 requests for engineering technicians in three months, and are having difficulty in filling the jobs. Letters or calls to graduates indicate that they, too, are practically all employed at rates that make the openings for beginners unattractive.

The positions offered vary from mechanical technician on a potato chip machine to one for work with computers, and include engineering aid, drafting, circuit design and industrial electronics. While most of the jobs appear to be one cut below engineering, some seem at-

tractive enough to interest (at least until something better comes along) those engineers who are still having difficulty getting back into the field.



**PICTURED ABOVE** is equipment used in the Air Force's newest airborne radar program, the Airborne Warning and Control System (AWACS). The radar equipment was designed and built by Westinghouse, winner of a contest with a competing design (see Radio Electronics December 1972, page 14). A high-flying, long-range surveillance system to detect and track aircraft. It can also, in peacetime emergencies, manage aircraft traffic and direct rescue operations. **R-E**

**Radio-Electronics** is published by Gernsback Publications, Inc. 200 Park Ave. S. New York, N.Y. 10003 (212) 777-6400  
President: M. Harvey Gernsback  
Secretary: Bertina Baer

### ADVERTISING SALES

#### EAST

Stanley Levitan, Eastern Sales Mgr.  
Radio-Electronics  
200 Park Ave. South  
New York, N.Y. 10003  
(212) 777-6400

#### MIDWEST/Texas/Arkansas/Okla.

Ralph Bergen  
The Ralph Bergen Co.  
6319 N. Central Ave.  
Chicago, Ill. 60646  
(312) 792-3646

#### PACIFIC COAST/Mountain States

Jay Eisenberg  
J.E. Publishers Representative Co.,  
8560 Sunset Blvd.,  
Suite 601,  
Los Angeles, Calif. 90069  
(213) 659-3810  
420 Market St.,  
San Francisco, Calif. 94111  
(415) 981-4527

#### SOUTHEAST

E. Lucian Neff Associates  
25 Castle Harbor Isle,  
Fort Lauderdale, Florida 33308  
(305) 566-5656

### MOVING?

Don't miss a single copy of **Radio-Electronics**. Give us:

Six weeks' notice

Your old address and zip code

Your new address and zip code

ATTACH  
LABEL  
HERE

name (please print)

address

city

state

zip code

Mail to: Radio-Electronics  
SUBSCRIPTION DEPT., BOULDER, COLO.  
80302

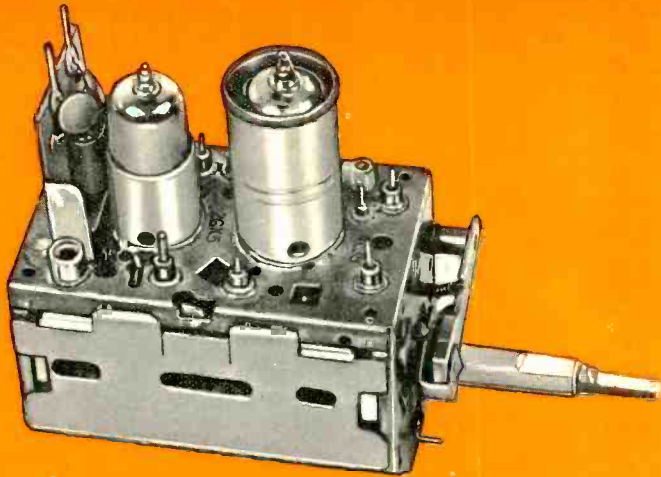

# \$9.75

**ALL PARTS INCLUDED**

except tubes and transistors

**ONE YEAR GUARANTEE**

## TUNER SERVICE CORPORATION

**PROVIDES YOU WITH A COMPLETE SERVICE FOR ALL YOUR TELEVISION TUNER REQUIREMENTS.**

### REPAIR

VHF Or UHF Any Type \$9.75.  
UHF/VHF Combo \$15.00.

In this price all parts are included. Tubes, transistors, diodes, and nuvistors are charged extra.

Fast efficient service at our conveniently located service centers. This price does not cover mutilated tuners.

All tuners are cleaned ultrasonically, repaired, realigned and air tested.



**WATCH US GROW**

### REPLACE

Universal Replacement Tuner \$9.75.

This price buys you a complete new tuner built specifically by SARKES TARZIAN INC. for this purpose.

All shafts have a maximum length of 10" which can be cut to 1½".

Specify heater type parallel and series 450mA or 600mA.

### CUSTOMIZE

Customized tuners are available at a cost of only \$15.95. (With trade-in \$12.95)

Send in your original tuner for comparison purposes to:

### TUNER SERVICE CORPORATION FACTORY-SUPERVISED TUNER SERVICE

Backed by the largest tuner manufacturer in the U.S.—SARKES TARZIAN, Inc.

<b>HEADQUARTERS</b> .....	537 SOUTH WALNUT ST., Bloomington, Indiana 47401	TEL: 812-332-7251
<b>ARIZONA</b> .....	2629 NORTH FIRST AVE., Tucson, Arizona 85717	TEL: 602-791-9243
<b>CALIFORNIA</b> .....	SARKES TARZIAN, Inc. TUNER SERVICE DIVISION	
	10654 MAGNOLIA BLVD., North Hollywood, Calif. 91601	TEL: 213-769-2720
<b>FLORIDA</b> .....	1505 CYPRESS ST., Tampa, Florida 33606	TEL: 813-253-0324
<b>GEORGIA</b> .....	938 GORDON ST., S. W., Atlanta, Georgia 30310	TEL: 404-758-2232
<b>INDIANA</b> .....	817 N. PENNSYLVANIA ST., Indianapolis, Ind. 46204	TEL: 317-632-3493
	6833 GRAND AVE., Hammond, Indiana 46323	TEL: 219-845-2676
<b>KENTUCKY</b> .....	2920 TAYLOR BLVD., Louisville, Kentucky 40208	TEL: 502-634-3334
<b>NEW JERSEY</b> .....	547-49 TONNELE AVE., Jersey City, New Jersey 07307	TEL: 201-792-3730
	(On U. S. Highway 1 & 9)	
<b>TENNESSEE</b> .....	1215 SNAPPS FERRY RD., Greeneville, Tennessee 37743	TEL: 615-639-8451
	1703 LAMAR AVE., Memphis, Tennessee 38114	TEL: 901-278-4484
<b>TEXAS</b> .....	11540 GARLAND RD., Dallas, Texas 75228	TEL: 214-327-8413
<b>VIRGINIA</b> .....	4538 PRINCESS ANN ROAD, Norfolk, Virginia 23502	TEL: 703-855-2518

Circle 7 on reader service card

# The GREATEST TV Schematic Bargain EVER Offered!

## Complete TV Schematics for less than 5c each

COVERS ALL COLOR TV 1960-1968 AND  
23 BRANDS B & W FROM 1965-1968

Here are FABULOUS savings on nationally-known TV schematic and service data—on everything you need to fill your vital service data needs for TV model years 1965 through 1968 . . . plus COLOR TV from 1960 through 1968! It amounts to a low, low cost of less than \$9.00 per year for your TV service data . . . with 5 more years of Color TV coverage thrown in for good measure!

### SERVICE DATA FOR 23 BRANDS

TV TECH/MATICS includes complete schematic diagrams and vital servicing data for every TV receiver produced by more than 20 leading American Manufacturers for 1965, 1966, 1967, and 1968. All diagrams and servicing details are completely authentic. Each year's coverage is permanently bound into two convenient-to-use volumes which open flat to 11" x 29½", ready to provide you with instant service data at your workbench. Some diagrams as large as 58" x 22"!

### HERE'S WHAT YOU GET

You receive 8 BIG volumes in all. Included is a clearly detailed and annotated TV schematic diagram for each specific model. You also get complete replacement parts lists, alignment instructions, tube and component location diagrams, plus key waveforms and voltage readings . . . all the information you need to service over 90% of the TV receivers you'll encounter!

Each volume is organized alphabetically by manufacturer, then numerically by model number. In addition, a handy Chassis/Model Finder is bound into each volume. Regular list price for each year's coverage—2 BIG volumes—is \$19.90. All 8 volumes normally sell for \$79.60. Your price is ONLY \$34.95 . . . a savings of nearly \$45.00!

### MONEY-BACK GUARANTEE

Order at our risk for FREE 10-day examination. Prove to yourself they are worth many times the price.

### CONTENTS

The 8 BIG volumes (2 for each year) cover all black-and-white receivers for model years 1965 through 1968—PLUS Color TV coverage from 1960 through 1968—for these brands: Admiral, Airline, Andrea, Coronado, Curtis Mathes, Dumont, Electrohome, Emerson, Firestone, General Electric, Hoffman, Magnavox, Motorola, Muntz, Olympic, Packard-Bell, Philco, Philco-Ford, RCA Victor, Sears Silvertone, Satchell-Carlson, Sonora, Sylvania, Truetone, Westinghouse and Zenith.

Publisher's List Price each year \$19.90  
Total \$79.60. Special price \$34.95 only while they last!



LARGE PAGES, 15x11", open flat to 29½x11".  
Provides complete schematic diagrams.

### NO RISK COUPON—MAIL TODAY

TAB Books, Blue Ridge Summit, Pa. 17214

I enclose \$34.95. Please send me your complete 8-Vol. Tech/Matics Schematic Offer postage prepaid. . . plus my 5 FREE SINGLPAK Manuals.

Please invoice me for \$34.95 plus postage. Same return privileges.

Name \_\_\_\_\_ Phone \_\_\_\_\_

Company \_\_\_\_\_

Address \_\_\_\_\_

City \_\_\_\_\_ State \_\_\_\_\_ Zip \_\_\_\_\_

Foreign, add 10%. Pa. add 6% sales tax. RE 63

Circle 8 on reader service card

# Letters

## FREE WORLD DX SEALS

To promote the World DX Friendship Year '73, Radio Nederland is issuing a gummed letter seal as shown here.

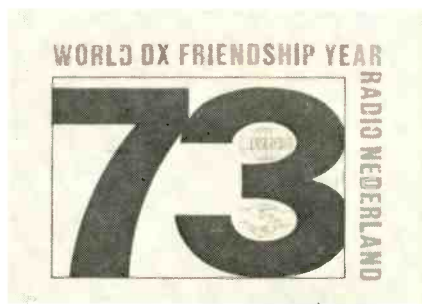

A sheet of 20 seals can be obtained free of charge from DX Juke Box, c/o Radio Nederland, P.O. Box 222, Hilversum, Holland.

HARRY VAN GELDER

*DX Producer*

*Radio Nederland*

*P.O. Box 222*

*Hilversum, Holland*

## ORBITS VS ORBITS

Since reading the January 1973 issue, I have been planning to write concerning a slight technical inaccuracy that I believe reflects the lack of understanding, on the part of many people, of a major factor in modern communications. It's been some time now, but I just ran across the article again and thought it may not be too late.

On page 34, in the article on Short-wave Television, the author mentions the placing of amateur-use satellites in strategic locations over the U.S. I have heard even communication engineers propose such a thing without really thinking about what they were saying.

You see, it is not possible to place a stationary satellite (and that *must* be what was implied) over any part of the United States. Most proposals for simplified satellite communication systems, including those of the big-time international services, include the use of a stationary satellite to obviate the need for sophisticated tracking equipment.

What many people seem not to realize is that the only place where you can put a geostationary satellite, that is one that appears to stay in one place in the sky, is over the equator. Some kind of outer-space reflector might be placed over some point in the U.S., but it will be a powered vehicle, not a satellite.

Some who might otherwise know better have confused the synchronous orbit satellite with the stationary one. In a synchronous orbit the satellite goes around the earth in precisely one day, but may be in any orbit plane. If the plane is over the poles, for example, the satellite will follow the same path across the earth every day, but it will not "sit still". Only if the orbit is synchronous and is also over the equator, with the satellite headed east, will the satellite appear to hang motionless (except for a few minor perturbations).

RICHARD H. HOUSTON

*Ricardson, Texas 75080*

## RINGS THE BELL

Your editorial, "Serviceability—Something For Everyone"—rings the bell.

May I suggest that you invite technicians to send in their pet gripes.

Mine is the way backs of portable TV sets are mounted. Sometimes it takes a great deal of fiddling to get them re-mounted. This is an unnecessary waste of time. Therefore I say—no antenna inputs—no speakers—no antenna rods should be mounted on the backs. Also, there should be a plastic panel in the bottom of the cabinet which can be removed to get at the bottom of the chassis.

Another sore point is the lack of standardization of the hardware—in the same set. Sometimes three different self tapping screws are used on tuners.

Plastic gears on tuners are another sore point. All uhf tuners should be separately tuned—no gearing.

JACK LANE

*Los Angeles, Calif. 90046*

## WATCH OUT FOR ROCK MUSIC

In Mr. Coronado's article's *Hard Rock And Your Hearing*, **Radio-Electronics**, March 1973, the point seems to be that at the expense of using forty of his unsuspecting, (or at least trusting) students as guinea pigs in a poorly-designed and useless experiment he has only succeeded in confirming what is well known about hearing loss attributable to exposure to high noise level.

In fact, had Mr. Coronado been the employer of his subjects he would be in violation of U.S. law.

One of the most amazing aspects of Mr. Coronado's cruel experiment is the foreknowledge he expresses in in-

*(continued on page 22)*



Don't let the handy size fool you.

The Serviset E/C is a complete, self contained versatile field test instrument. A precision-built, reliable, much-used instrument to compliment your VOM, scope or other equipment, too.

The Serviset E/C is great for servicing all sorts of electronics in the field and on the bench. Whether you're a professional engineer working on communications or EDP devices. An electronics or appliance technician working in radio, television, hi-fi audio or appliance repair. Or an amateur electronics enthusiast, ham radio operator or student.

Checks you'll make with the Serviset E/C include: sync, sweep, video, audio circuits; high or low DC, RF, or pulse voltage supplies; coils, capacitors, resistors, tubes, transistors, diodes, transformers, speakers--whatever you're trouble-shooting from stage to stage, or discrete components. What's more, your Serviset E/C is safe: whatever you check, you won't blow it.

The Serviset E/C. The \$35. Electronic Test Lab (almost) that will follow you anywhere. One of an advanced line of guaranteed electronic test devices from Lee that will save you time and effort. Including our CT-1 Condenser Tester and Leakage Indicator.

\*send check or money order. C.O.D., send \$2. deposit.

Serviset E/C, \$34.95 postpaid \*from Lee Electronic Labs.  
Available also at electronic dealers and all Olson Stores, nationwide.

## The \$35. Electronic Test Lab (almost) that will follow you anywhere: Serviset E/C



**Lee Electronic Labs, Inc.**

BOX 78, WATERTOWN, MASS. 02172 (617) 891-8686

# Great careers

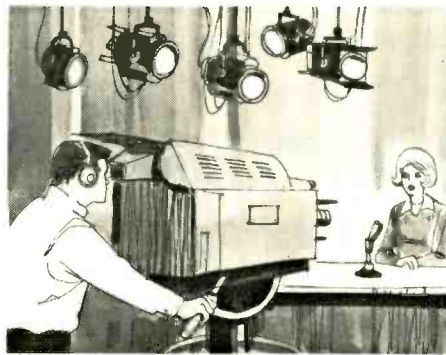

## Join the high-paid electronics technicians who got their start through NTS Home Training.

Your home can become your own private classroom-workshop. NTS sends you everything you need to learn valuable technical skills in electronics. You get easy-to-grasp lessons, comprehensive kit manuals, large fold-out charts, and more. Plus the finest professional equipment available today. It's all included in your tuition, yours to keep.

You'll work with commercially-designed equipment, and school training material. Cash in on the tremendous opportunities in the expanding, exciting world of electronics.

If your field is television, you might decide to join a first-class TV repair center. Or start a shop of your own. Or specialize in industrial applications of television. Once you master an area of electronics, the direction you take is really up to you. And you'll be able to use the test instruments you built yourself.

It all begins at home, with NTS Project Method Training. Check card or coupon today for free full-color NTS Catalog and complete details. No obligation. No salesman will call.

### NTS COLOR AND B&W TV SERVICING

Build the largest most advanced color TV made! It's a Heath! Over-all solid-state design, 315 sq. in. ultra-rectangular screen, 24 channel detent UHF/VHF power tuning, matrix picture tube, built-in self-servicing features, "Instant On," A.F.T., solid-state VHF tuner, and much more! This is a commercial set, the kind you'll encounter in the field — and not for training purposes only. Also build and keep AM-SW Radio, Solid-State Radio, FET Volt-Ohmmeter, and Electronic Tube Tester. Learn trouble-shooting, stereo multiplex systems, radio, color and B&W TV servicing.

**Solid-state B&W TV 74 sq. in. picture (cabinet included)**



Learn advanced solid-state circuitry as you build this B&W TV receiver. Course covers the full range of home entertainment electronics

### NTS AUDIO ELECTRONICS SERVICING

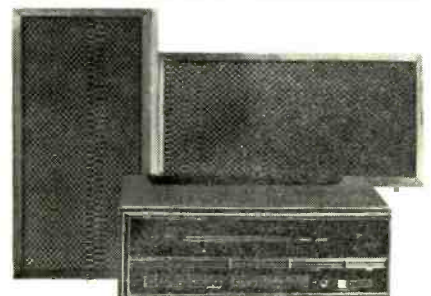

**Solid-state Heath Stereo Receiver and Speakers**

Learn sound theory — how it works in home radio, 4-channel, and more! Set up a spectacular music system. Learn about sound distortion, amplification and control, loud-speaker baffles, problems of system installation, etc. Included is Volt-Ohmmeter, In-Circuit Transistor Tester and solid-state Radio. Prepare yourself for great opportunities in the Home Entertainment Industry!

# begin at home.



**New solid-state  
315 sq. in. color TV**



**The exclusive  
NTS Compu-Trainer**

## NTS COMPUTER ELECTRONICS

Build and operate the exclusive NTS Compu-Trainer! Loaded with integrated circuits, it teaches you the how, what, and why of computers — faster, more thoroughly. You perform all wiring and patch-cording. No shortcuts! No pre-wired circuit boards. Also receive an FET Volt-Ohmmeter and a 5" wide-band Solid State Oscilloscope.

## NTS ELECTRONIC COMMUNICATIONS

Gain the prestige and earning power of owning an FCC First Class Radio Telephone License! Two exciting courses in the fields of transmitting and receiving. Experiment with an amateur phone 6-meter VHF transceiver, NTS exclusive 6-transistor solid-state radio and a fully transistorized volt-ohmmeter.

**5-watt AM transmitter/receiver.**

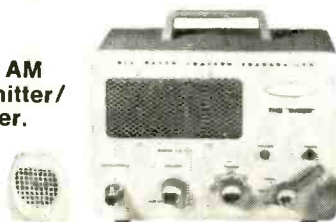

## NTS AUTOMATION/ INDUSTRIAL ELECTRONICS

Systems automation is the future of the industry — and you can play an important role! Enter the age of electronic controls by training on the NTS Electro-Lab — a complete workshop. Also receive a Solid State 5" wide-band professionally rated Oscilloscope. Build five industrial controls to regulate motor speed, temperatures, pressure, liquid level and much more.

**5" Solid State Oscilloscope**



## CLASSROOM TRAINING AT LOS ANGELES

You can take classroom training at Los Angeles in sunny Southern California. NTS occupies a city block with over a million dollars in facilities devoted exclusively to technical training. Check box in coupon.

## APPROVED FOR VETERANS

Accredited Member: National Association of Trade and Technical Schools: National Home Study Council.

## NATIONAL TECHNICAL SCHOOLS

Resident & Home Study Schools  
World-Wide Training Since 1905  
4000 S. Figueroa St., Los Angeles, CA 90037

**Please rush Free Color Catalog and Sample Lesson, plus information on course checked below. No obligation. No salesman will call.**

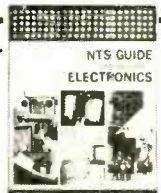

### National Technical Schools

Resident & Home Study Schools  
World-Wide Training Since 1905  
4000 S. Figueroa St., Los Angeles, CA 90037

- Master Course in Color TV Servicing
- Color TV Servicing (For Advanced Technicians)
- Master Course in B&W TV & Radio Servicing
- Master Course in Electronic Communications
- Practical Radio Servicing
- FCC License Course
- Master Course in Electronics Technology
- Automation & Industrial Electronics
- Computer Electronics Dept. 206-063
- Basic Electronics
- Audio Electronics Servicing

Name \_\_\_\_\_ Age \_\_\_\_\_

Address \_\_\_\_\_

City \_\_\_\_\_ State \_\_\_\_\_ Zip \_\_\_\_\_

- Check if interested in Veteran Training under new G.I. bill.
- Check if interested ONLY in Classroom Training at Los Angeles.

# ARROW AUTOMATIC STAPLE GUNS

## CUT WIRE & CABLE INSTALLATION COSTS

... without cutting into insulation!

**SAFE!** Grooved Guide positions wire for proper staple envelopment! Grooved Driving Blade stops staple at right depth of penetration to prevent cutting into wire or cable insulation!

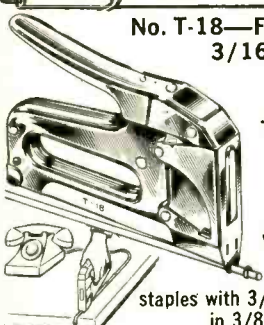

**No. T-18—Fits wires up to 3/16" in diameter.**

**BELL, TELEPHONE, THERMOSTAT, INTERCOM, BURGLAR ALARM and other low voltage wiring.**

Uses T-18 staples with 3/16" round crown in 3/8" leg length only.



**No. T-25—Fits wires up to 1/4" in diameter.**

Same basic construction and fastens same wires as No. T-18.

Also used for **RADIANT HEAT WIRE**

Uses T-25 staples with 1/4" round crown in 9/32", 3/8", 7/16" and 9/16" leg lengths.

T-18 and T-25 staples also available in Monel and with beige, brown and ivory finish at extra cost.

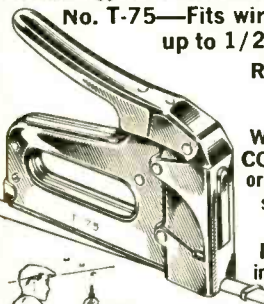

**No. T-75—Fits wires and cables up to 1/2" in diameter.**

**RADIANT HEAT CABLE, UF CABLE, WIRE CONDUIT COPPER TUBING or any non-metallic sheathed cable.**

Also used as **DRIVE RINGS** in stringing wires.

Uses T-75 staples with 1/2" flat crown in 9/16", 5/8" and 7/8" leg lengths.

Arrow Automatic Staple Guns save 70% in time and effort on every type of wire or cable fastening job. Arrow staples are specially designed with divergent-pointed legs for easier driving and rosin-coated for greater holding power! All-steel construction and high-carbon hardened steel working parts are your assurance of maximum long-life service and trouble-free performance.

Ask your Electrical Supply Dealer or write for further details.

**ARROW FASTENER COMPANY, INC.**  
Saddle Brook, New Jersey 07683  
**"Pioneers and Pacesetters  
For Almost A Half Century"**

### LETTERS

(continued from page 16)

roducing the experiment to your readers... "It is well known that prolonged exposure to sound levels of 100 dB in some instances may result in permanent irreversible damage to the inner ear."

Next he describes his experiment indicating he produced a constant level of over 100 to 120 dB, for three hours, even though his survey of discotheques indicated less severe 90 to 100 dB levels. Finally, Mr. Coronado indicates that he doesn't know whether the radically impaired hearing of his subjects ever improved because he was unable to test them the next day... (or presumably in the days since.)

Please inform your readers that the Walsh-Healy act sets a time limit on exposure to sound of 115 dB sound levels for no more than 15 minutes. I am not in the habit of writing letters of complaint but because of my area of work I am keenly aware of the severity of Mr. Coronado's experiment and want to minimize its possibility of repetition by some young or ignorant reader.

Other than this article, I am and have been an avid **Radio-Electronics** reader.

D. L. MILLER  
Harrisburg, Pa.

### REPAIR RATES

Service technicians, in general, applaud the fact that manufacturers are beginning to accept responsibility for their products. It is a wise decision to employ the independent service industry to help in this effort. We recognize that the final cost of this effort is legitimately passed on to the consumer.

Dealer views regarding warranty repair vary widely. A sales oriented dealer might expect to have to subsidize his service department. Any type of payment schedule is an improvement for this dealer who previously received nothing. Others do warranty work in the expectation of building future out-of-warranty business. Because of special considerations, others find warranty repairs profitable. Our view is that repairs must be profitable whether in warranty or out.

I don't know the method other dealers use to calculate service charges. My method is hardly scientific. It is this. We operate efficiently with competent people. We are reasonably provident. When we have difficulty meeting our financial obligations—we increase our rates.

This simple method of necessity has imposed the following schedule.

1. A basic hourly charge of \$15.00, with a minimum shop charge of:
  - B&W portable .....\$15.00
  - B&W console.....\$20.00
  - Color TV.....\$25.00

2. We have no maximum shop rate, however, with the exception of combination models with multiple problems we have not charged over \$45.00 shop labor.

Our philosophy is that the minimum charge be high enough to compensate for the occasional tough dog. Insurance companies operate on this same principle.

3. On home service calls we make a trip charge of \$10.00 plus \$15.00 per hour. As an example, 1/2 hour spent in the home would be:

Trip charge.....	\$10.00
Home labor.....	\$ 7.50
Total.....	\$17.50

We charge by 1/4 hour increments and the customer benefits from the odd time.

4. For the repair that cannot be completed in the home and requires shop facilities, the charges are itemized thus:

<b>Color TV</b>	
Trip charge.....	\$10.00
Home labor, pick up, install.....	\$20.00
Shop time.....	\$25.00 to 45.00
Total.....	\$55.00 to 75.00

<b>B&amp;W TV</b>	
Trip charge.....	\$10.00
Home labor, pick up, install.....	\$15.00
Shop time.....	\$20.00 to 35.00
Total.....	\$45.00 to 60.00

We recognize that a warranty repair can be accomplished more quickly than a repair on the same TV three years later. The newer chassis and cabinet do not require cleaning. Generally, the alignment is okay. Tuner maintenance probably is not required. Additional time is required for warranty paper work and parts handling.

For all of the above reasons our estimate is that we can accomplish an in-warranty shop repair in about 70% of the time required for the older TV. I don't know the exact percentage. Nevertheless, it is an important figure for the industry to know exactly, because it is the only one we have in common.

Each servicer has arrived at his own present customary rate schedule after years of trial. The process is individualistic. It is not the result of collusion with other servicers. It does take into consideration that income is also derived from parts sales. It is not the result of average-time studies.

It is not the manufacturer's role to attempt to change this process. He should cooperate in it to our mutual benefit or find the "average" shop to act as his service agency. A job-rated schedule that is offered on a take it or leave it basis is a source of annoyance in a relationship that should be harmonious.

DICK HOLMES, CET  
Dick Holmes TV Service  
Fallon, Nev. 89406

R-E

# Those also serve, who test or measure or protect or adapt or sit around & tell time.

AC ADAPTER Equips any MITS 1200 Series pocket calculator for operation from 110 VAC ..... \$6.95

### DC4/DC6 DIGITAL CLOCKS

6 DIGIT [hours, minutes, seconds]  
 DC6-E [electronics only] ..... \$49.50  
 DC6-K [complete kit] ..... \$58.50  
 DC6-M [assembled unit] ..... \$99.50  
 4 DIGIT [hours, minutes, and 1 sec. pulsed colon]  
 DC4-E [electronics only] ..... \$39.50  
 DC4-K [complete kit] ..... \$48.50  
 DC4-M [assembled unit] ..... \$89.50  
 Specify 12 or 24-Hour Operation on Assembled Units

### PS-500 POWER SUPPLY

Kit ..... \$29.95  
 Assembled ..... \$39.95

### ICT-1800 IC TESTER

Kit ..... \$119.95  
 Assembled ..... \$169.95

### CARRYING CASES

1230/1240 Padded leatherette or rigid vinyl ..... \$9.95

1200 Series High quality leatherette carrying case ..... \$5.95



# MITS®

WRITE OR MAIL COUPON FOR  
 ADDITIONAL INFORMATION:

## Micro Instrumentation & Telemetry Systems, Inc.

5404 Coal Ave., S.E., Albuquerque, New Mexico 87108

505/265-7553

ENCLOSED IS A CHECK FOR \$ \_\_\_\_\_  
 or  BANK AMERICARD # \_\_\_\_\_  
 or  MASTER CHARGE # \_\_\_\_\_  
 or  PURCHASE ORDER # \_\_\_\_\_

INCLUDE \$5.00 FOR POSTAGE AND HANDLING

MODEL # \_\_\_\_\_  KIT

PLEASE SEND INFORMATION ON ENTIRE MITS LINE.  ASSEMBLED  
 ELECTRONICS

NAME \_\_\_\_\_

ADDRESS \_\_\_\_\_

CITY \_\_\_\_\_

STATE & ZIP \_\_\_\_\_

MITS / 5404 COAL AVE. SE / ALBUQUERQUE, N.M. 87108

RE 6

Circle 11 on reader service card

**A. Build your own Heathkit  
25V Color TV...599.95\*** less cabinet

The GR-900 is the most advanced TV you can build. Yet everything goes together with traditional Heathkit simplicity. And the built-in convergence board and test meter for at-home maintenance add further savings over the life of the set. You preset any 12 UHF channels for positive pushbutton power tuning, and you can scan both UHF and VHF channels in either direction. An ultra-rectangular black matrix tube, voltage controlled varactor UHF tuner, MOSFET VHF tuner and an exclusive angular tint control for better flesh tones combine to produce an absolutely brilliant color picture. Mailing weight, 125 lbs.

**B. Heathkit 18V  
Color TV...349.95\*** less cabinet

Solid-state modular circuitry spells reliable operation and easy assembly. And the GR-269 comes with a full complement of alignment and self-service equipment — dot generator, convergence board, test meter and troubleshooting book. Factory assembled and aligned AFT module for perfect picture & sound at a touch. VHF tuner with MOSFET circuitry

and UHF tuner with hot-carrier diode design for low noise, high sensitivity. Both tuners & IF assembly factory assembled & aligned "instant-on", switch-controlled degaussing, hi-fi sound output; 75 & 300 ohm antenna inputs; exclusive Heath Magna-Shield, standard. Mailing weight, 100 lbs.

**C. Heathkit 14V  
Color TV...299.95\*** includes cabinet

Set aside about a dozen evenings. Build up 10 circuit boards, prepare the chassis. Install the wiring harness. Result: the Heathkit GR-169, with picture purity at the top of its class. And you keep it that way — with plug-in modular circuit boards, troubleshooting meter and data book to help you fix it right at home. A "big" little TV, the GR-169 has all the secondary controls found in our larger models —

color, tint, contrast, horizontal & vertical hold, height, AGC, color killer, switch-controlled degaussing. Carry it room to room or across the country — this is the portable that bounces back with console-like performance. Mailing weight, 69 lbs.

**D. NEW Heathkit 19V B&W  
Portable TV...179.95\*** includes cabinet

The new GR-1900 is like no other B&W portable! With advanced solid-state "modular" design — most circuitry mounts on just 4 plug-in boards. Just 2 tubes; picture & high voltage. Total detent tuning on all 70 UHF channels as well as VHF. "Instant-on." Front panel controls of VHF/UHF fine tuning; brightness; contrast, master on/off; vert. hold; AGC & height. New ultrarectangular tube for a full 184 sq. in. view. Other

# Start a Heathkit hobby...

It's fun, easy, and it  
saves you money.

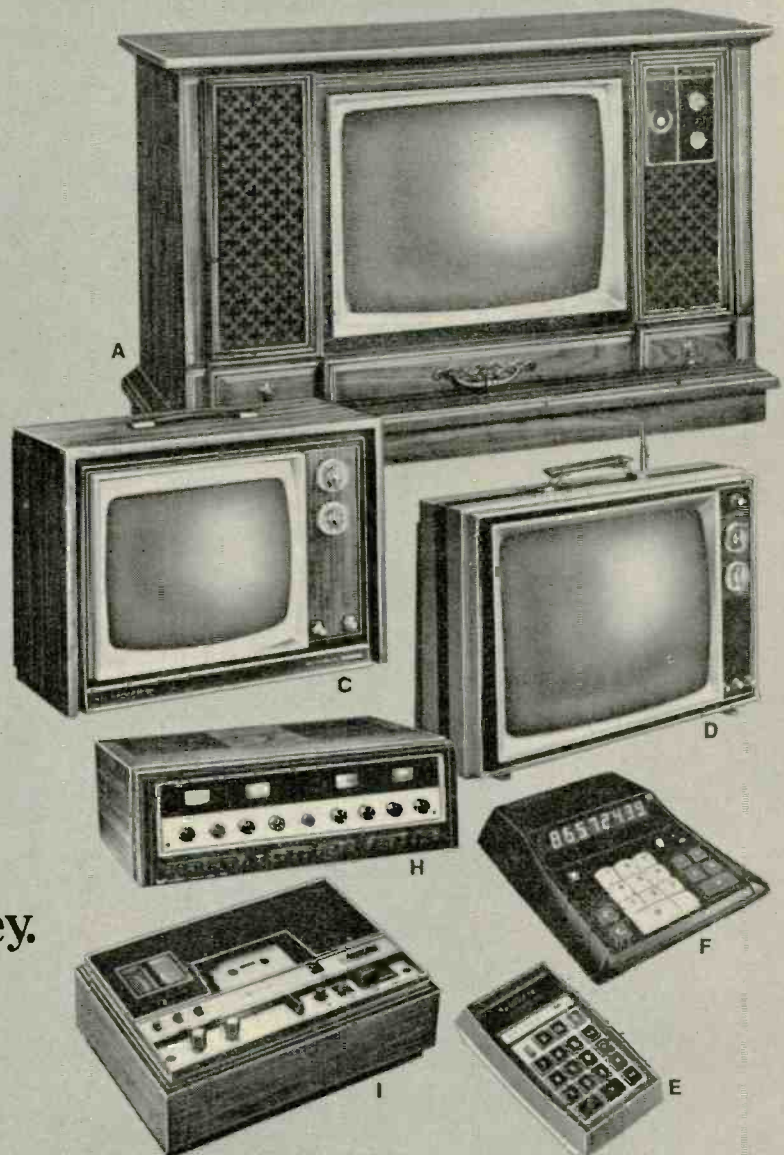

"big" set features are Automatic Vertical Linearity; dual-controlled AGC; extra-wide Video Bandwidth; 4-circuit grounded-base VHF tuner. A kit even the novice can build; both tuners come preassembled & aligned; transistors & ICs plug into sockets; and all chassis wiring is color coded. Mailing weight, 56 lbs.

**E. NEW Heathkit Pocket Calculator... 92.50\***

The new Heathkit IC-2009 is a fully portable calculator with rechargeable nickel-cadmium battery. Or you can leave it connected to the plug-in charger for permanent desk-top use. Weighs just 12 oz. And check over these features: 8-digit capacity. Four arithmetic function. Floating decimal. Constant key. Chain calculation capability. Clear-entry key. Entry & total overflow indicators. Low battery indicator. Battery-saver circuitry. And you can build it in three evenings. Mailing weight, 3 lbs.

**F. New Heathkit Desk-top Calculator... 79.95\***

The Heathkit IC-2108 — a great looking full-function electronic calculator for home or office. You can assemble it in two spare evenings. Features

include: Addition, subtraction, multiplication and division functions. Floating and fixed decimal. Constant key. Chain calculation capability. Clear display key. Entry and result overflow indicators. Negative answer indicator. 120 or 240 Volt operation. Mailing weight, 4 lbs.

**G. New Heathkit Small-engine Tune-up Meter... 39.95\***

Kit CM-1045 — for all 2- and 4-cycle engines, 1 to 4 cylinders, with conventional, CD, or transistorized ignitions. Great for motorcycles, snowmobiles, outboard marine engines, etc. Clip-on leads let you check dwell, volts, ohms and continuity without tearing down the engine to get at systems buried beneath the flywheel. A built-in inductive-pickup tachometer works with any number of cylinders. Blue high-impact plastic case stores leads and three "C" batteries for ultimate portability. Mailing weight, 5 lbs.

**H. Heathkit 4-Channel Amplifier with decoder... 359.95\* less cabinet**

You select discrete 4-channel, or switch-in the "Universal" decoder for reproduction of all the matrixed 4-channel discs now on the market, plus "derived" 4-channel from conventional stereo. Four solid-state amplifiers produce 200 watts (4x50 IHF) into 8 ohms, with power bandwidth on all channels from less than 5 Hz to greater than 45 kHz at 0.25% distortion.

Kit AA-2010, mailing weight, 37 lbs. AAA-2004-1, pecan cabinet 24.95\* Mailing weight, 7 lbs.

**I. Heathkit Cassette Deck with Dolby circuitry... 249.95\* less cabinet**

The Heathkit AD-1530 is a kit-form cassette deck utilizing the famous Dolby® noise reduction system. Accommodates the greater fidelity and dynamic range of chromium dioxide cassettes. Independent switches provide Dolby on/off and regular or CrO<sub>2</sub> bias control. Domestic-make tape transport comes preassembled for easy kit building. Mailing weight, 20 lbs.

**J. New Heathkit AM Radio... 14.95\***

The Heathkit GR-1008 is a smartly styled, great sounding solid-state radio that makes a great introduction to Heathkit building. Eight-transistor circuitry mounts on one printed board, big 3½" speaker mounts in high impact plastic case. If you've never built a kit before you can probably have this one together in one fun evening. Uses 9-volt battery (not supplied). Order the Heathkit GR-1008 for yourself or the kids. Mailing weight, 2 lbs.

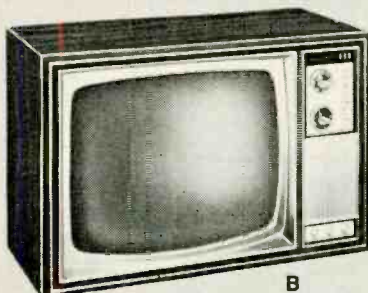

B



G

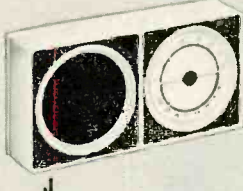

J

**OVER 350 KITS TO CHOOSE FROM IN THIS NEW FREE CATALOG**



**SEND FOR YOUR FREE**

**1973 HEATHKIT CATALOG**

— it describes more than

350 Heathkit projects

HEATH COMPANY, Dept. 20-6  
Benton Harbor, Michigan 49022

Please send FREE Heathkit Catalog.  
Enclosed is \$ \_\_\_\_\_, plus shipping

Please send model(s) \_\_\_\_\_

Name \_\_\_\_\_

Address \_\_\_\_\_

City \_\_\_\_\_ State \_\_\_\_\_ Zip \_\_\_\_\_

\*Mail order prices; F.O.B. factory CL-469



# LOW COST DIGITAL KITS

## NEW BIPOLAR MULTIMETER: AUTOMATIC POLARITY INDICATION



### Model ES 210K

Displays Ohms, Volts or Amps in 5 ranges • Voltage from 100 Microvolts to 500 V • Resistance from 100 Milliohms to 1 Megohm • Current from 100 Nano Amps to 1 Amp ..... \$77.00  
Case ex: \$12.50 (Optional probe) \$5.00

### 40 MHz DIGITAL FREQUENCY COUNTER:

- Will not be damaged by high power transmission levels.
- Simple, 1 cable connection to transmitter's output.



ES 220K — Line frequency time base. 1 KHz resolution. 5 digit: \$69.50 Case extra: \$10  
ES 221K — Crystal time base. 100 Hz resolution. 6 digit: \$109.50 Case extra: \$10.00

### DIGITAL CLOCK:



ES 112K/124K • 12 hr. or 24 hr. clock \$46.95  
Case extra: Walnut \$12.00 • Metal \$7.50

### CRYSTAL TIME BASE:

ES 201K — Optional addition to ES 112K, 124K or 500K. Mounts on board. Accurate to .002%.  
Kit Price \$25.00

### I D REMINDER:

ES 200K Reminds operator 9 min. 45 sec. have passed. Mounts on ES 112 or 124 board. Silent LED flash \$9.95. Optional audio alarm \$3.00 extra.

Dependable solid state components and circuitry. Easy reading, 7 segment display tubes with clear, bright numerals. These products operate from 117 VAC, 60 cycles. No moving parts. Quiet, trouble free printed circuit.

Each kit contains complete parts list with all parts, schematic illustrations and easy to follow, step by step instructions. No special tools required.



**ORDER YOURS TODAY:**  
Use your Mastercharge or  
BankAmericard  
Money Back Guarantee

10418 La Cienega • Inglewood, Ca. 90304  
(213) 772-6176

Circle 12 on reader service card

# equipment report

## Electrix electrical kit

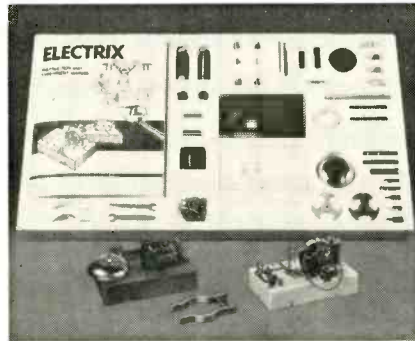

Circle 29 on reader service card

ELECTRIX IS AN ELECTRICAL EXPERIMENTERS kit that has been developed to help the user learn basic electrical theory. It has been popular with German youths for many years and is now available in the U.S.A. through Edmund Scientific Co. The kit includes over 135 precision engineered components and a 112 page instruction manual. Its parts includes two 2.7-volt light bulbs, two small wrenches for making the nut-and-bolt electrical connections, magnet wire, solenoids, hook-up wire, magnets, armature segments, and utility and galvanometer consoles. The consoles are plastic bases that are used when assembling most of the experimental devices. They include space for two cells and holes for components and mounting screws. Catalog No. 71647. \$17.95.

Basic electricity is taught through the study of switching circuits, series and parallel connections, current flow, magnetism and by experiments involving the construction and use of such things as sockets, switches, electric bells and buzzers, electromagnets, simple motor, generators, earphone, microphone, galvanometer and a magnetic compass. The manual leads you step-by-step through each experiment and explains what it is supposed to demonstrate. In the front of the manual it states, that all experiments have been tried and will work as described. However it was not stressed that you must do the experiments in the order that they appear; step-by-step, page-by-page, chapter-by-chapter. The man-

ual starts with a simple experiment and then just adds more on, re-enforcing what you have already learned. Try to start with an experiment in the middle of the book and you are in deep trouble! You won't be able to complete it!!! I guess that this is what makes this kit different from others I've had. Most of the others are mainly for entertainment, this one is educational as well.

I recommend this kit to anyone from 11 years old on up who wants to learn about simple electricity and how things work. I had a little trouble with some of the experiments because some of the parts were not fully illustrated or described and I needed adult help in locating some of them.

Working with this kit will help you understand magnetism, and electricity when you study them in school.

The Electrix kit includes everything that you need except four C cells. It comes in a box 24 by 14 by 2½ in. with notches and recesses to hold the various components. It is a simple kit suitable for the beginner who wants to learn as he plays. As a 13-year-old, I recommend it to any boy—or even girl—over this age.—Gregory Scott  
R-E



"We'll probably operate first thing in the morning and keep it in the recovery room a few days to make sure it doesn't have a relapse."



# NEW LOW PRICES ON WINEGARD® QUALITY ACCESSORIES!

set couplers—2-way splitters—band separators—matching transformers <sup>reduced up to</sup> **31%**

Why buy "second line" TV components when you can buy the best . . . Winegard engineered-and-built for less and get the same high quality and performance?

Check with your distributor for new low pricing on these items.

**Reduced 14%**

**CS-285 300 OHM V-U BAND SEPARATOR**—High quality, low loss Band Separator for adapting single 300 ohm downlead to separate 300 ohm VHF and UHF antenna connections of TV set. Perfect match insures perfect color and black and white reception.



**Reduced 31%**

**CC-482 82 CH. 4-SET COUPLER**—Deluxe low loss coupler connects four TV-FM sets to a single 300 ohm downlead. Efficient coupler circuit provides a maximum amount of signal to each receiver. Specially designed for color, black and white and stereo.



**Reduced 31%**

**CS-387 75 OHM V-U-FM BAND SEPARATOR**—Band Separator for making connection between 75 ohm coaxial downlead and separate 300 ohm antenna terminals of TV set and FM receiver. Features latest printed circuit design for low loss, high isolation and perfect match. Excellent for quality color and FM stereo reception. Connector included.



**Reduced 22%**

**CS-175 75 OHM V-U BAND SEPARATOR**—Quality 75 ohm Band Separator for attaching coaxial cable to separate 300 ohm antenna terminals of TV set. Features printed circuit and latest circuitry for low insertion loss and perfect color transmission. Connector included.



**Reduced 28%**

**CS-380 300 OHM V-U-FM BAND SEPARATOR**—Latest Band Separator design adapts 300 ohm downlead to separate VHF and UHF antenna terminals of TV set and provides FM stereo thru handy no-strip screw terminals. Unique printed circuit design has extremely low loss, excellent match and high isolation for perfect color and FM stereo.



**Reduced 26%**

**CC-33 82 CH. 2-SET COUPLER**—Inexpensive coupler for connecting two TV or FM sets to a single 300 ohm downlead. Features handy no-strip terminals for easy connection.



**Low Price!**

**LS-27 82 CH. LINE SPLITTER**—High quality line splitter for dividing a single 75 ohm coaxial cable into two trunk lines. Indoor type with transformer network features excellent match. Connectors included.



**NEW**

**Low Price!**

**T-12BLK 82 CH. MATCHING TRANSFORMER**—Compact indoor Matching Transformer for attaching coaxial cable to 300 ohm antenna terminals of TV or FM receiver. Packed 6 per poly bag, 8 bags per master carton. Connectors included.



**NEW**

**Reduced 26%**

**CC-282 82 CH. 2-SET COUPLER**—Efficient 300 ohm coupler connects two TV-FM sets to a single 300 ohm downlead. Input and output connections are handy no-strip type for easy installation. Quality circuitry insures perfect color and black and white reception.



**WINEGARD**  
ANTENNA SYSTEMS

3000 KIRKWOOD ST. • BURLINGTON, IOWA 52601

Circle 13 on reader service card

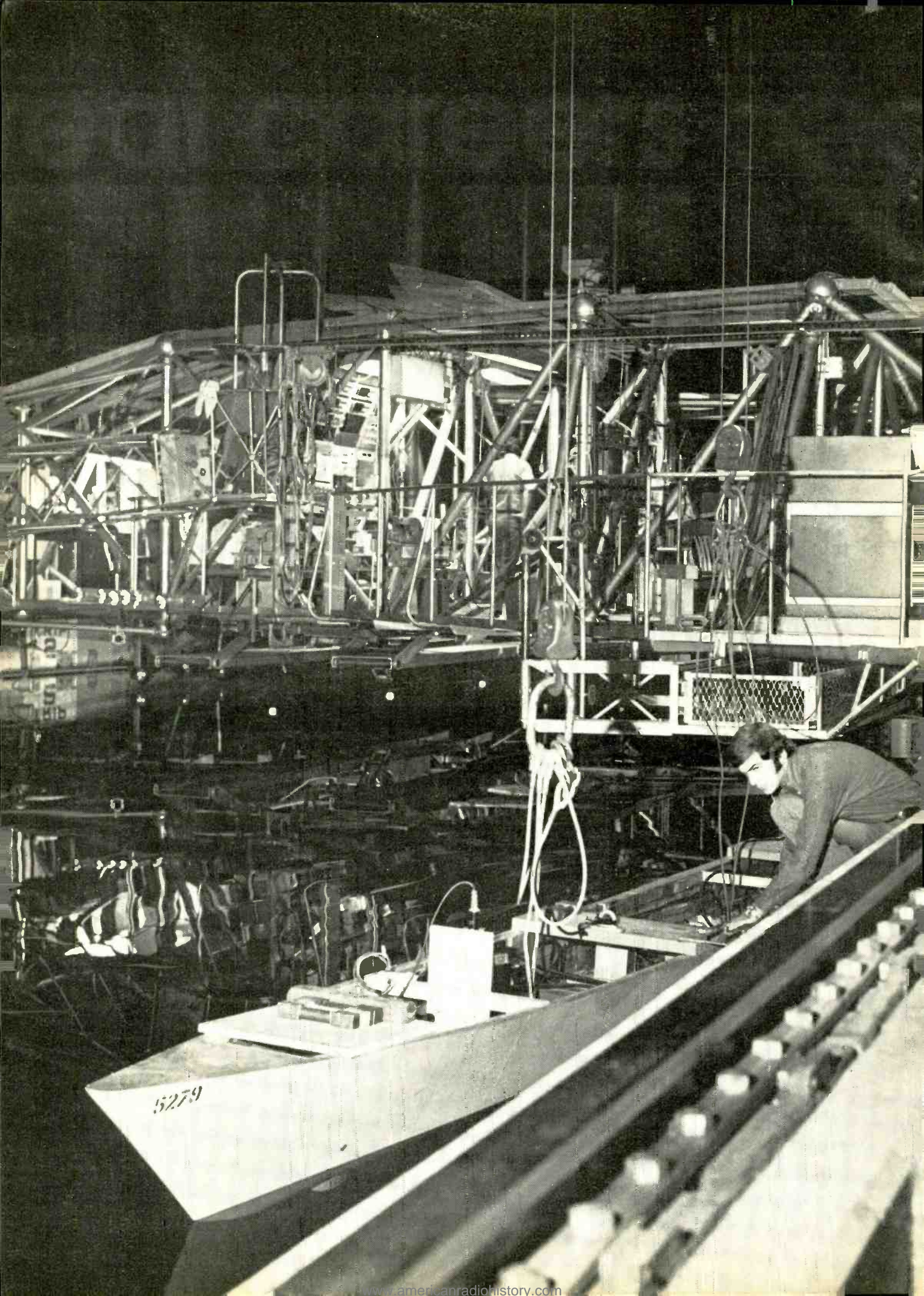

5279

# If you're looking for a career instead of a job in electronics ...

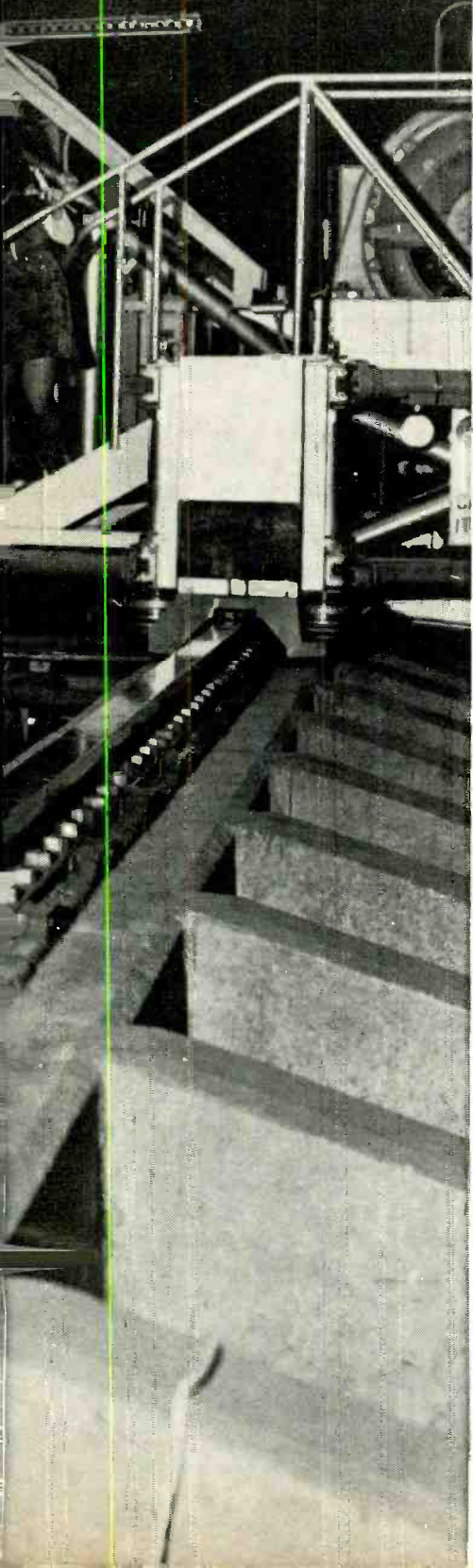

It costs millions of dollars to build modern ocean going vessels. The final design of such ships is based on extensive testing with sophisticated electronic measuring equipment using exact models as shown in the photo of the Naval Research and Development Center. The engineering technicians who check out, maintain and repair such equipment have to be experts. Their work is not only interesting and exciting, they also enjoy top pay in their field.

CREI offers Electronic Engineering Technology programs through home study. You have a choice of *eighteen* different program arrangements so you can specialize in exactly the area of electronics you want. All of the programs, except a brief introductory course, are college-level.

If you want to qualify for the highest paying level of technical employment in electronics, we invite you to consider the unique home study programs of CREI. Here is a list of just some of the CREI programs: *Communications Engineering • Computer Engineering • Missile & Spacecraft Guidance • Radar & Sonar • Television Engineering • Nuclear Instrumentation & Control • Digital Communications • Industrial Electronics • Electronic Systems Engineering • Microwave Communications • Satellite Communications • Cable Television Engineering*

For over 45 years, CREI programs have been recognized by leading technical organizations as effective home study training in advanced electronics.

**Qualifications to Enroll.** To qualify for enrollment in a CREI program, you must be a high school graduate (or equivalent). You should also be working in electronics or have previous training in this field.

**Send for FREE book.** If you are qualified, send for CREI's newly published book describing your career opportunities in advanced electronics. This full color book is filled with facts about career opportunities for you.

**Capitol Radio Engineering Institute**  
A Division of McGraw-Hill Continuing Education Co.  
3939 Wisconsin Avenue, Washington, D. C. 20016



Accredited Member, National Home Study Council

CREI, Dept. E1406D  
3939 Wisconsin Avenue  
Washington, D.C. 20016

Rush me your FREE book describing my opportunities in advanced electronics. I am a high school graduate.

Name \_\_\_\_\_ Age \_\_\_\_\_

Address \_\_\_\_\_

City \_\_\_\_\_ State \_\_\_\_\_ ZIP \_\_\_\_\_

If you have previous training in electronics, check here

Employed by \_\_\_\_\_

Type of Present Work \_\_\_\_\_

Veterans and servicemen, check here for G. I. Bill information

**CREI**  
**CAPITOL**  
**RADIO**  
**ENGINEERING**  
**INSTITUTE**  
WASHINGTON, D.C.

ANYTHING



# II COULD DO III CAN DO BETTER!

Several years ago, we decided that our next challenge would be to go beyond the best there was. Our computers told us we had taken the existing cartridge structure and stylus assembly of the V-15 Type II Improved as far as we could, and that hereafter, any improvement in one performance parameter would be at the expense of performance in some other parameter.

Therefore, over the past several years, a wholly new *laminated cartridge* structure has been developed, as was an entirely new stylus assembly with a 25% reduction in effective stylus mass! These developments have resulted in optimum trackability at light tracking forces ( $\frac{3}{4}$  –  $1\frac{1}{4}$  grams), a truly flat, unaccented frequency response, and more extended dynamic range than was possible even with the Type II Improved, without sacrificing output level!

Further, because these factors are held in perfect equilibrium, wherein each design parameter enhances every other parameter, the total audio effect is greater than the sum of its individual engineering achievements. Engineers call this effect a Synergistic Reaction; ergo, we call the Type III the Synergistic Cartridge.

If you like its sound today, you will like it even more as time goes on. In fact, to go back to any other cartridge after living with the Type III for a short while is simply unthinkable, so notable is its neutral, uncolored sound. You must hear it. \$72.50.

INTRODUCING THE NEW



## V-15 TYPE III Super-Track "Plus" Phono Cartridge

Shure Brothers Inc. • 222 Hartrey Ave. • Evanston, Ill. 60204  
In Canada: A. C. Simmonds & Sons Ltd.

Circle 14 on reader service card

JUNE 1973 • RADIO-ELECTRONICS 33

# Here's everything you'd expect from a high-priced portable multimeter.

## Except a high price.

The B & K Solid-State Electronic Multimeter (Model 277) has 8 important features that you can get on most other quality-made units, but not at prices like ours.

You'd expect to pay quite a lot for a multimeter featuring both high and low power ohms ranges. Both are critically necessary. The B & K 277, with its .068 V power source on low power ohms, will always read the true value of a resistor shunted by a semi-conductor without concern for the semi-conductor's presence. A con-

ventional ohmmeter with a 1.5 volt supply could cause a shunt semi-conductor to conduct, giving a false resistance reading.

The 277's high-power resistance ranges are useful in determining whether transistors are good or bad simply by first forward biasing them to make them conduct and then reversing the leads to qualify the front-to-back ratio.

The B & K 277 has so many features you wouldn't expect at the price: like a .1 V low-voltage scale for both AC and DC; a DC current range of

1  $\mu$  A full-scale for testing sensitive semi-conductor leakage; the unit is fully protected from overloads by fuse; input impedance of 15 M  $\Omega$  on DC; 1% precision resistors; a 4 1/2 inch, 50  $\mu$  A mirrored scale meter; frequency response to 150 KHz and 59 individual ranges.

Our price alone doesn't make it a value, but our features at our price make it a fantastic value.

# \$99<sup>95</sup>

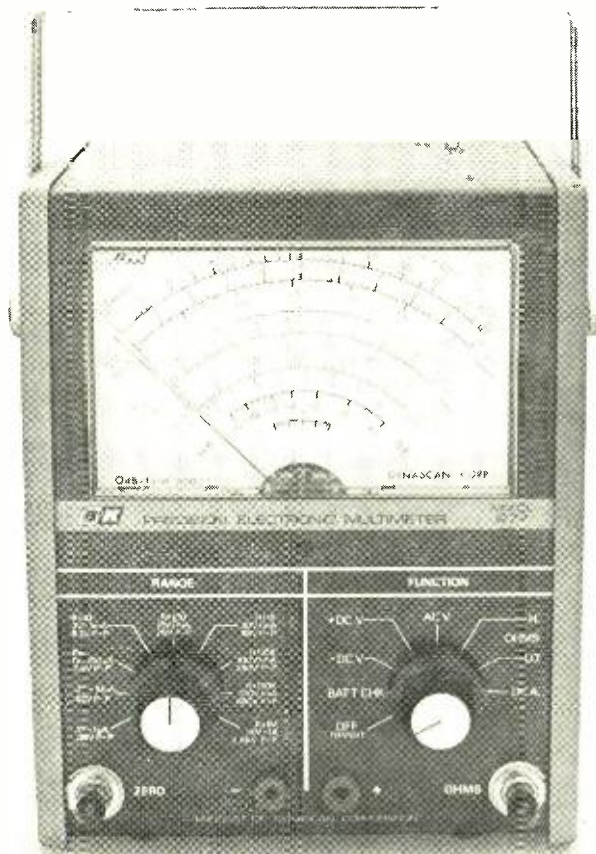

**B & K** Very good equipment at a very good price.

Product of Dynascan Corporation/1801 W. Belle Plaine Ave., Chicago, Ill. 60613

NOW YOU'LL HAVE NO MORE MISSED phone calls with this home-built Phone Sentry on the job. It automatically answers the phone for you and takes the caller's message.

The Phone Sentry features an electronic control unit you can build yourself. It is used along with one or two *unmodified* cassette tape recorders. When the Phone Sentry is not being used, you may use the recorders for other purposes.

Several recent developments have made this Phone Sentry possible and practical: inexpensive cassette recorders, an endless loop cassette on which you record your "answer message", two new integrated circuits, and highly reliable yet low-cost reed relays. With the Phone Sentry, the equivalent of an expensive phone answering service is available to the smallest businesses and even for home use at a fraction of the cost of units now on the market. If you build the unit yourself, the parts will cost you \$29.50, or you can buy an assembled and tested unit for \$49.50 (assembled price includes a 30-second endless loop tape).

The heart of the Phone Sentry is an electronic control unit that "answers" the phone, sequences the tape recorders, and "hangs up" after the caller's message is recorded. The unit is triggered by the telephone ring. A relay is energized which turns on the answer tape player. At the end of the answer message, a pre-recorded tone signal causes the answer player to be turned off and the message recorder to be turned on. The message recorder remains on for 30 seconds to record the caller's message, then it and the entire unit is automatically turned off. The Phone Sentry is then ready to receive the next call.

### Building the control box

Mount the four reed relays, the two integrated circuits, transistor Q1, the neon lamp, capacitors, and resistors on the printed circuit board as shown in the pictorial diagram. Observe capacitor and diode polarities and proper orientation of IC1 and IC2. Pin 1 of IC1 and IC2 can be determined by the dot or depression in the top of the case. Mount the neon lamp on the foil side of the board and bend the leads so it lies flat against the board.

Connect 2-foot 2-wire leads to T1 and T2 (these will go to plugs P1 and P2) and to RY3 and a six-inch twin lead to RY4 (these will go to P3 and PLAYBACK switch). Using 3 6-inch leads, connect a spdt pushbutton switch (this will be the TONE button) as follows: the common terminal to C6, the normally closed terminal to ground, and the normally open terminal to the primary of T2. Connect a

spst pushbutton switch using two 6-inch leads to TEST terminal (near R1) and to normally open contact of S1-6 (ON/OFF switch); this will be the TEST button.

Connect a 6-foot twisted pair cable to common terminal (near C2) and to ON/OFF switch S1-a. Connect the other side of S1-a to RY1 terminal with a 6-inch lead. Use another 6-inch lead to connect S1-6 to RY2 and connect the other side of S1-6 to positive lead from the battery holder. The negative lead from the battery holder connects to common (near C2).

Mount the printed circuit board and battery holder in the case. Connect a 2-foot twin lead to N.O. terminals of the PLAYBACK switch (goes to P4). The 2-wire lead from RY4 is already on these terminals. Bring out the five leads and solder the proper plugs (P1-P4) to their respective ca-

bles. Place a piece of white tape around the cables to P1 and P3 and mark on the tape ANSWER UNIT No. 1. Put a similar tape on the cables to P2 and P4 and label it MESSAGE RECORDER UNIT No. 2. A four-pin telephone plug, or any plug to match your phone jack, can be mounted on the LINE cable. Mount the four switches to the front cover of the case.

After you assemble the control unit, record your answer message on the endless loop cassette. The following message is just one example: "Hello. This is Roger Smith. Your call is being answered by an automatic Phone Sentry. This is because I am either away or unable to answer the phone at this time. However, I would like to return your call. Will you please leave your phone number or message at the sound of the tone, and I will call you back as soon as pos-

# build a phone sentry to take your calls

*A simple adapter  
mates inexpensive  
cassette recorders  
to phone line.*

by ROGER L. SMITH



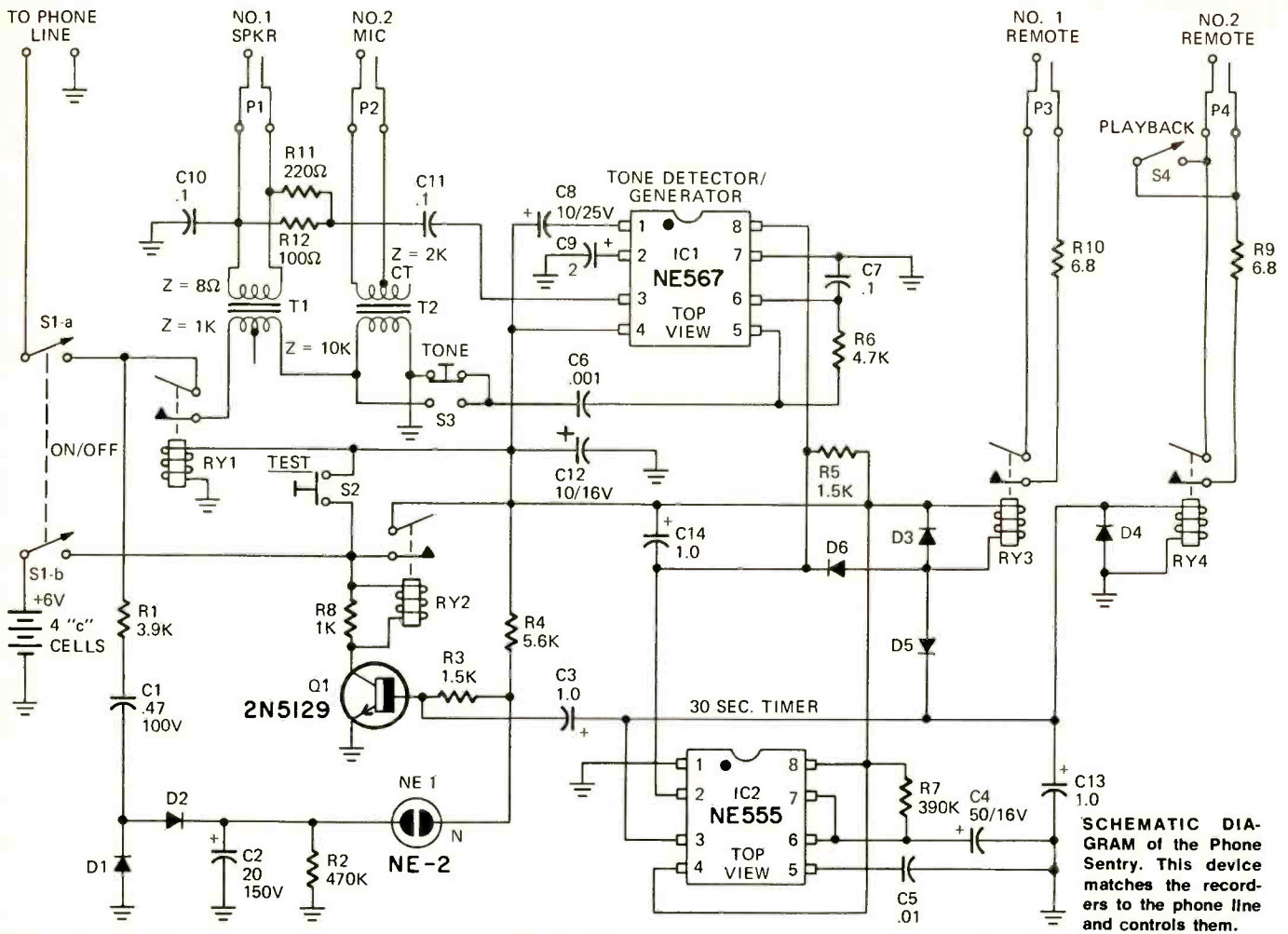

**SCHEMATIC DIAGRAM** of the Phone Sentry. This device matches the recorders to the phone line and controls them.

- All resistors 1/4 watt**  
 R1—3900 ohms  
 R2—470,000 ohms  
 R3, R5—1500 ohms  
 R4—5600 ohms  
 R6—4700 ohms  
 R7—390,000 ohms  
 R8—1000 ohms  
 R9, R10—6.8 ohms  
 R11—220 ohms  
 R12—100 ohms  
 C1—.47  $\mu$ F, 100V Mylar  
 C2—20  $\mu$ F, 150V electrolytic  
 C3, C13, C14—1.0  $\mu$ F, 25V electrolytic  
 C4—50  $\mu$ F, 16V electrolytic

- C5—.01  $\mu$ F, 25V disc  
 C6—.001  $\mu$ F, 25V disc  
 C7, C10, C11—.1  $\mu$ F 25V disc  
 C8—10  $\mu$ F, 25V electrolytic  
 C9—2  $\mu$ F, 25V electrolytic  
 C12—10  $\mu$ F, 16V electrolytic  
 NE1—NE-2 neon lamp  
 RY1, RY2, RY3, RY4—4 reed relays, 6-volt coil, spst (Electronic Applications)  
 IC1—NE 567V tone decoder IC (Signetics)  
 IC2—NE 555V timer IC (Signetics)  
 T1—Miniature audio output transformer (1,000 ohms to 8 ohms impedance)  
 T2—Miniature driver transformer (10,000 ohms to 2000 ohms, ct)

- D1-D6—1A silicon diodes, IN4001 or equal  
 Q1—n-pn, 2N5129 or equal  
 P1, P2, P3, P4—phone plugs (type as req'd)  
 S1, S4—dpst slide switch  
 S2, S3—dpdt push button switches  
 MISC: PC board, 2-conductor speaker cable (18'), solder, endless-loop cassette tape (TDK type EC-30S or equiv.), plastic battery holder for 4 "C" cells, plastic instrument case (6 x 5 x 2)  
**NOTE: A kit of all of the above parts except the endless loop tape can be obtained for \$29.50 (plus postage for 1 1/2 lb.) from Southwest Technical Products Co., 219 W. Rhapsody, San Antonio, Texas 78216**

sible. Remember, leave your phone message at the sound of the tone. Thank you for calling." The answer message should be about five seconds shorter than the playing time of the endless loop (30 seconds in this case). Now, insert plug P2 from the Phone Sentry into the microphone jack of the answer unit No. 1, and plug P3 into the REMOTE jack. Turn the Phone Sentry on, place the recorder in the RECORD mode and momentarily depress both the TEST and TONE push buttons, then turn off the Phone Sentry. Now turn off recorder and remove P2. You will now have a short tone signal of the proper frequency recorded at the end of your answer message on the endless loop tape. Whenever you make a new answer message and tone signal, be sure the Phone

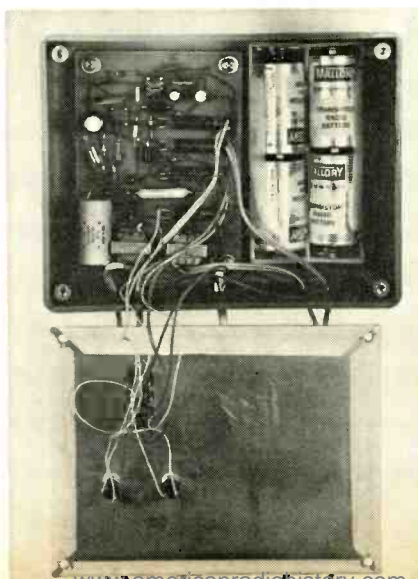

Sentry is disconnected from the phone line. You may have to check your watch closely when making the recording so you don't overlap the end of the message or the tone with the beginning of the message.

You are now ready to test your Phone Sentry. Connect the answer player unit No. 1 to plugs P1 and P3 (plug P1 to the "earphone" jack and P3 to the "remote" jack). Turn on the player to the "play" mode. Connect the message recorder unit No. 2 to

**If anyone experiences trouble with the message recorder coming on instead of the answer player, add a 1- $\mu$ F capacitor to the bottom of the PC board between pins 1 and 8 of IC2, the NE555. Connect the plus lead to pin 8 and mount it as close as possible to IC2. C12 provides filtering for IC1 but is not close enough to IC2 to bypass transients around it.**



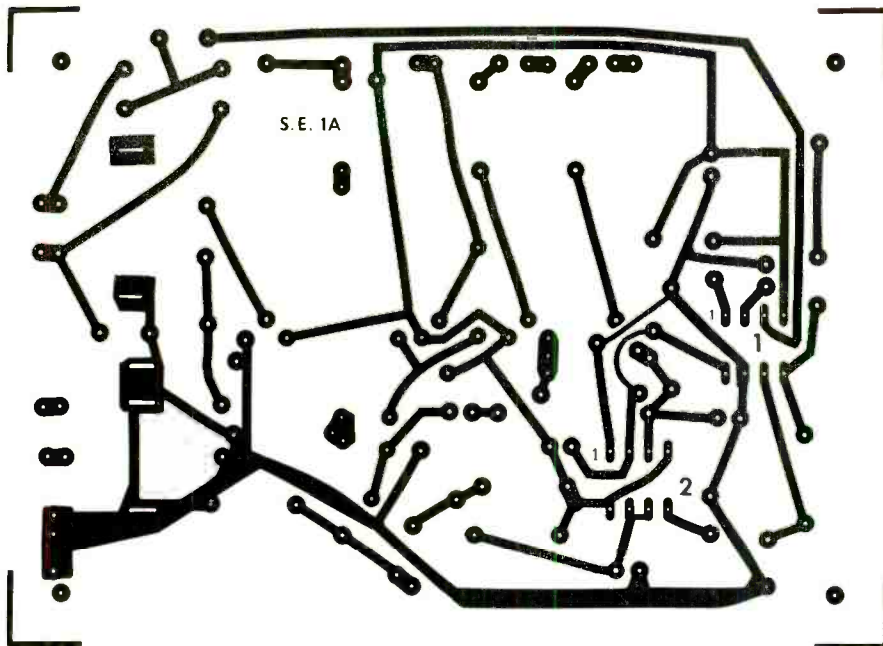

INTERCONNECTION WIRES TO BOARD

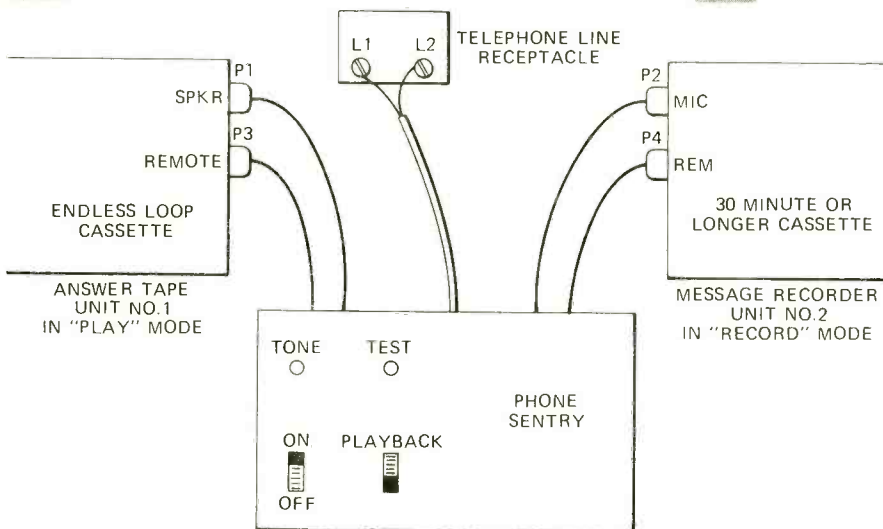
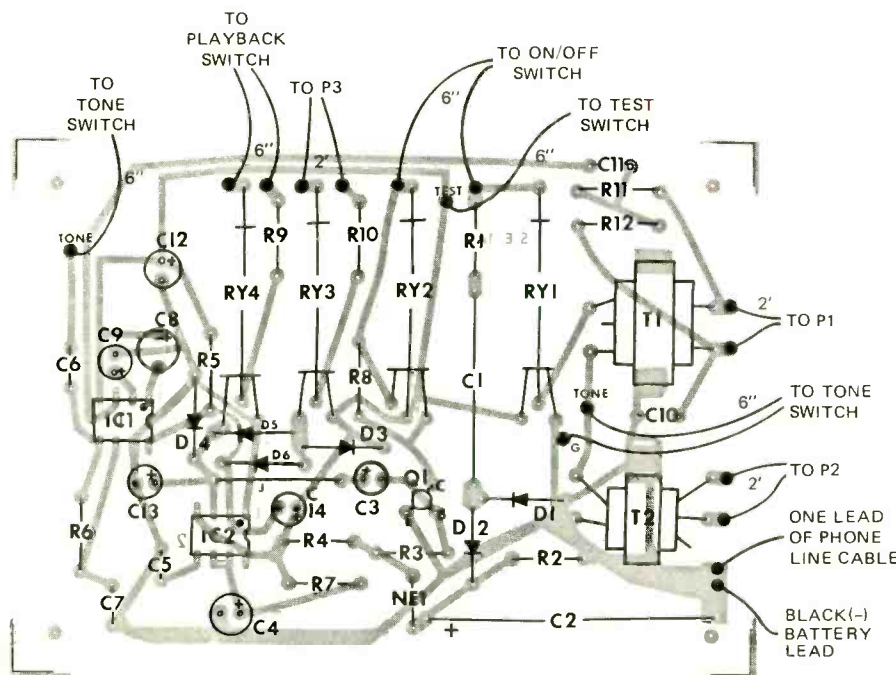

SYSTEM INTERCONNECTION

FOIL PATTERN (at left) for the Phono Sentry is fullsize. Parts are placed as in the middle illustration. Watch diode and capacitor polarities. The bottom diagram shows Phono Sentry connections to two unmodified cassette recorders and phone line.

plugs P2 and P4 (plug P2 to the "microphone" jack and P4 to the REMOTE jack). Turn on the recorder to the RECORD mode. With ON/OFF switch of the Phono Sentry on, depress the TEST button. The answer player should run for thirty seconds until the tone signal turns it off and turns the message recorder unit on. The message recorder should run for about 30 seconds and then both units should go off.

If all seems well, you can connect the LINE cable to the red and green (or L1 and L2 or T and R) terminals of the phone line. Your telephone junction box may have 3 or more wires, but connect only to the two mentioned. Have a friend call you to test the unit. As soon as the Phono Sentry acquires the line, the answer player should start and you can monitor the call by picking up your receiver. A little experimentation may be necessary to arrive at the proper volume control setting for your cassette recorders.

If your unit doesn't operate properly, check all connections and verify proper plug placement. Be sure all batteries are new since a balky recorder will cause a malfunction. Check the circuit theory section and schematic to help you track down your trouble. Also, try reversing the leads to the phone line.

Battery life using regular "C" cells should be 2 months (based on 20 calls per day). You should check your batteries or replace them periodically to insure trouble-free operation. The Phono Sentry can also be used with recorders that have ac battery eliminators.

The endless TDK loop cassette tape is highly recommended for use with the Phono Sentry because it simplifies the operation. Although it costs about \$4, the investment is well worth it. Also available are endless loop cassettes of 1 minute, 3 minutes, 6 minutes and 12 minutes. These would be useful for special cases where an announcement only is desired. As you may have noticed, any type of tape recorder that has a remote on/off feature can be used as the message recorder unit No. 2.

It is possible that you do not need to record the caller's message in your particular application. This would be the case of a theatre, advertising message, or store hours announcement. In such instances, simply

(continued on page 82)

by FRED PETRAS

Astute observers are quick to tell you that in addition to colossal, spectacular achievements, the home electronics industry is noted for colossal egos and spectacular ego-complications. To name some of the latter: The battle of record speeds of the late forties, Columbia with its LP, RCA with its 45-rpm disc; The hassle between Columbia and RCA over a color TV broadcasting system in the early fifties; The struggle between GE, Zenith and others to get acceptance of their individual approaches to FM stereo broadcasting, early in the sixties; The war of "convenience" tape Formats—RCA/Lear versus Muntz, then RCA/Lear/Muntz versus Norelco—that flared in the mid sixties; and the conflict of quadriphonic sound, now raging between RCA/Panasonic/JVC ganged against Columbia and Sansui, plus Columbia versus Sansui. There's also the battle of the video record/play formats between several companies, which started in the mid sixties and still rages hot.

Each conflict represents an engagement of individual and/or corporate egos, each struggling for dominance, each wanting to be "The Champ." Each battle represents waste on a grand scale: waste of money, time, human energy, talent and resources, and other elements. But until some "super-psychiatrist" comes along and resolves the Champ syndrome, freeing the companies to realistically function *together*, the waste will continue. And the matter of standardization that the VTR segment of the electronics industry needs to make it a household word—and a mass-market product—will also remain unresolved.

### Standards: Whose? Which?

In fact, the problem of VTR standardization seems even further from resolution. Consider the proliferation of systems: 1, Those now in the marketplace; 2, Those on the way in the near future, and; 3, Other systems farther off in the future.

Standardization is no longer the relatively simple matter of 1966 when it was primarily a decision as to which tape width. Today it's far more: a matter of "Which system?" and "Which system *within* a system?" For instance, if you opt for the convenience approach, you have to decide if it's the half-inch, three-quarter-inch, or one-inch cartridge. If you decide on the

**FULL HOUR PLAY OR RECORD** from International Video's VCR-100. Operator inserts cartridge and pushes the PLAY button.



**STUDIO PRODUCTION VTR** for recording and playback is International Video's new VCR-100, useful for both recording and playback.

**AT TOP RIGHT** is RCA's SelectaVision Mag-Tape color tape player/recorder with XL-100 TV receiver as a monitor and signal source.

half-inch size, then it's a matter of deciding "Which cartridge—Omnivision, VCR, or Cartrivision?" The situation is further complicated by variations in terminology. Panasonic and Cartridge Television Inc. refer to their half-inch convenience formats—Omnivision and Cartrivision—as a cartridge. Norelco refers to its half-inch VCR magazine as a cassette. The three-quarter-inch Sony U-Matic is also called a cassette. RCA's upcoming MagTape is called a cartridge. International Video Corp. (IVC) calls its one-inch convenience format a cartridge. If you decide to go the video disc route, you again face up to "Which one?", with your choice encompassing three incompatible close-to-reality concepts, Teldec, Disco-Vision (MCA) or VLP (Video Long Play) (Norelco).

Anyone trying to get a "fix" on the VTR field finds that after a lot of research the feeling is that reel-to-reel VTR will eventually be confined largely to the broadcast field, and will be a highly specialized format. The encased magnetic tape formats will be bought by those wanting a choice of record/playback or just playback facilities. The disc formats will be for those wanting only playback of pre-recorded program materials.

According to Alvin Barshop, assistant general manager of Panasonic VTR/CCTV

sales, "There are certain parallels to be drawn between the VTR and the film, audio tape, and other industries. In VTR, each cartridge/cassette video format is unique and has its advantages and features, and each serves a certain need in the marketplace. Each has its negatives. We at Panasonic are not here to set standards, but to serve the market what it needs." The company produces both formats, plus reel equipment. Barshop went on to say that the three-quarter-inch videocassette would serve well where 60 minutes of playing time and two sound tracks were essential, as in home entertainment programming. The half-inch cartridge format with its half-hour playing time and single sound track, and impor-

**RECORD AND PLAYBACK** version of a three-quarter inch video tape cassette. This is the model 2120 from Panasonic.



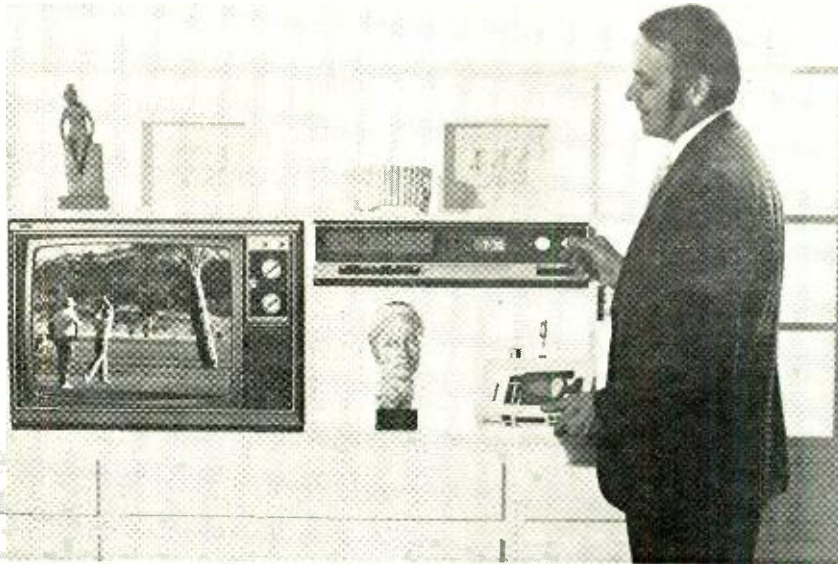

# VTR's— many different systems

*Home video recording is almost here. Compare the different systems described and see if you can pick the industry's standard of tomorrow.*

tantly, EIAJ standardization for broad use on a variety of machines, would serve well for the industrial market where 90% of all programming is under 30 minutes.

Proponents of the disc system point out that the playback equipment will be cheaper than for tape playback equipment. Discs will also be cheaper, because the materials will cost less, and because mass production techniques can be used to make the end product. The predictions are that video disc costs will be in the same ballpark as high-end stereo records, overall. Further, the discs will be easier to mail. Mass distribution of video discs is likened to selling a newspaper. In fact, there is talk that someday a video disc will accompany the daily newspaper for special purposes . . . like capsule rundowns of key stories of the day, in sound, plus motion, in full color.

Opponents of the video disc note that

while it may achieve a high level of popularity, that popularity will be related to program availability. To be a success, the format will require tremendous supplies of program material—possibly beyond the capacity of the software industry. If consumers sense the supply will be inadequate, they may decline to invest in the equipment.

Many crystal-ballers—taking a cue from the current home electronic product scene with its multiple-system ownership ambience—see the same happening in the VTR

**COLOR AND BLACK-AND-WHITE are recorded on Norelco video cassette machine at lower left.**

**CARTRIDGE VIDEO RECORDER below is the model NV-5120P from Panasonic.**

**HALF-INCH TAPE is in the cartridge for the compact color and black-and-white video recorder at right. The model is Panasonic's NV-5125.**

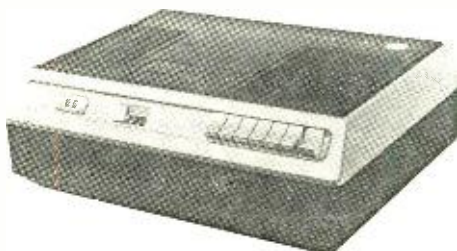

field. They envision homes with *two* VTR systems, one strictly for playback, the other for recording *and* playback. The first will be the video disc, the latter magnetic tape in some sort of magazine.

Other industry observers take the view that each system has its merits. They suggest that instead of being concerned about which system—or systems—will, or may, predominate, the potential purchaser of a VTR should stop waiting and direct his concern to studying the individual approaches actually available now, and settle on one that appears best for his particular needs and desires. They add that the purchaser should be aware of “future shock,” and not necessarily consider his purchase to be a life-time proposition. They equate a VTR system to an automobile, asserting that the average buyer of a car does not buy it with finality in mind. Rather, the car is thought of as “the latest” in an on-going technology, and that it is but one of a series of purchases.

## Recent happenings

A chart of VTR products was published in the July, 1972 issue of **Radio-Electronics**. It was devoted to some 75 models in the under-\$4,000 price range, actually in the marketplace. Absent were any EIAJ-recommended-standard color versions of the half-inch cartridge concept. That concept hit the market late in 1972, and there are now several models in retail stores, with more on the way in the near future. Among key companies with half-inch EIAJ-recommended-standard color cartridge models are Panasonic (Matsushita), JVC, Shibaden, and Sanyo.

Last year's chart showed JVC, Sony and Wollensak as having U-Matic type cassette machines. That list has expanded to include models from Panasonic and Concord. Upcoming are U-Matic sets from the MGA division of Mitsubishi International Corp.

The roster of companies committed to Cartrivision has decreased by two—Emerson and DuMont. Both have left the home entertainment product field. The concept is actively being marketed by Admiral, Montgomery Ward, Teledyne Packard Bell, and Sears Roebuck.

North American Philips has started retailing its “VCR” (Video Cassette

Recorder) system mentioned as "on the way" in our previous wrapup. Utilizing half-inch magnetic tape in a twin-reel cartridge, the concept uses a rotary two-headed helical-scan system and a tape speed of 6.75 ips. Playing time is a top of 50 minutes per cassette using 17-micron tape. A one-hour cassette using thinner tape was said to be possible. A blank 50-minute tape costs \$32.50. The cassette measures 5¼ x 5 x 1½ inches.

The VCR record/playback deck sells for \$1,295. (A playback-only version may be along later, at a lower price.) It offers horizontal resolution of 240 lines, audio bandwidth of 120 to 12,000 Hz within 6 dB, and signal/noise ratios of 40 dB in video and audio. The unit looks like, and operates much like an audio cassette deck. It measures approximately 18¼ x 13¼ x 6¼ inches.

N. V. Philips of the Netherlands has

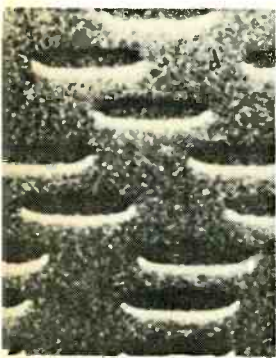

**PHILIPS VLP SYSTEM** uses a vinyl-coated metal disc with microscopic pits carrying the necessary video and audio information. At left is surface of VLP as seen through scanning electron microscope.

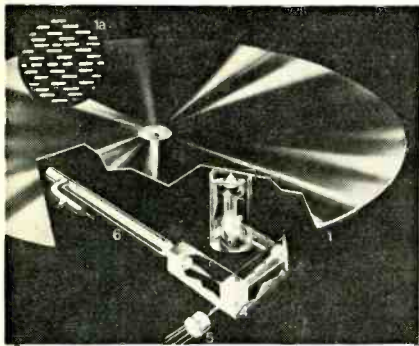

10 licensees for VCR in Europe, one in Japan (Shiba Electric) and is negotiating with several potential licensees in the U.S.

Since our wrapup last July another video cartridge tape format—totally unheralded—appeared. It's from International Video Corp. (IVC), Sunnyvale, California. Claiming to be "the most compact configuration of any VCR on the market, while providing the highest performance in the VCR field," the new VCR-100 series uses self-threading *one-inch* video tape cartridges that are *tape interchangeable* with over 10,000 other IVC open-reel videorecorders now in use.

Tape in the cartridge is connected to a leader and threads itself automatically onto a permanent reel inside the recorder much the same as film in an automatic-threading film projector. The cartridge is designed for the standard 8-inch, one-hour NAB reel. Tapes made on IVC cartridge recorders can be removed from the cartridge and played on existing IVC one-inch open reel recorders. Tapes produced on master recorders

can be easily placed in an IVC cartridge by the user, for playback. Running speed of the tapes is 6.91 ips. Playing time is a maximum of one hour. Standard or high-energy tape is used. It is made for IVC by 3M Co.

Three models are available: a color playback version at \$1,900; a color recorder/player priced at \$2,700; and a monochrome recorder/player for \$2,300. The portable-cased units measure 17½ x 12½ x 7¾ inches and weigh 45 pounds.

For the moment, IVC is running alone with its format. No software program per se is under way, a company official told us. He noted that software would be developed by users of the VCR-100 series, and if duplication was required, it could be handled by specialists such as Consolidated Video Systems. He added that the format was enjoying strong acceptability in the cable TV field, with Teleprompter, for one, standardizing on the IVC one-inch format for all its program production. IVC also has a half dozen VTR's in one-inch reel form in production in the \$1,800 to \$4,000 range.

Among other noteworthy recent additions to the VTR product scene is a versatile new half-inch reel model (EIAJ Type One standard) from JVC, model KV360, priced at \$1,060. It records and plays at 7½ ips, but can additionally play back at slower speeds, for slow-motion studies of sports activities, etc.

Another versatile newcomer is Sanyo model VTR-1200, a half-inch reel model (EIAJ Type One standard) with four ferrite-crystal video heads. The unit has five operating modes: standard (7½ ips) speed, slow-motion, accelerated-motion, seven-hour recording, and stop-motion/frame-by-frame advance. It is priced at \$2,395.

On the color camera front, Akai has brought out a six-to-one zoom model with 300-line horizontal resolution. The 5¼-pound unit has a built-in microphone and employs a ⅜-inch separate-mesh vidicon for its luminance channel. The tube is contained in the camera's vertical hand grip. The camera is compatible with any color video tape system currently sold in the U.S. industrial market. The camera, model CVC-150, comes as a system complete with power supply and adaptor, at \$3,495.

EVR—electronic video recording—is apparently not near the demise predicted for it on the heels of CBS's abandonment of production and marketing of the concept in the U.S. EVR is actively being marketed in Japan, Canada, Australia, and some Arab countries by Mitsubishi Electric Corp. of Tokyo. The firm is also test marketing EVR in the U.S. through its MGA division in Chicago, but plans for actual marketing have not been concluded. Mitsubishi is part of a partnership called Nippon EVR, Ltd., formed in Japan last fall, and includes Teijin, Hitachi, and Mainichi Broadcasting "to exploit the EVR system world-wide" according to a brochure prepared by the original EVR Partnership of Imperial Chemical Industries, Ltd., of the United Kingdom, and CIBA-Geigy Ltd. of Switzerland. Toshiba is also reported to be marketing EVR in Japan.

Our chart last year showed Motorola to be marketing an EVR player in the U.S. It is no longer doing so. However, the firm is continuing to produce program materials for EVR via its Teleprogram Center. The same programming is also available in the

Sony U-Matic, plus Super-8 and 16-mm film formats.

Last year we talked about several video film systems, some under development, others at the talk stage. Little has happened in this medium, judging by the lack of publicity since last summer. However, vague rumors persist that a video-player attachment using Super-8 movie film will appear—when, no one seems to know. It may be based on Kodak's "feasibility" model detailed in these columns earlier, or based on a system developed by Polaroid.

As for the much-talked-about Holotape laser beam, half-inch vinyl film, play-only system announced by RCA a few years ago, it is "pretty much on the shelf" for the moment, according to an RCA spokesman. But the company is still continuing research on the idea.

### In the works

Last July we stated that RCA's "Mag-Tape" three-quarter-inch color video cartridge system was on the way, likely to see the light of day this year. That's still true. RCA says MagTape will be in commercial production by year's end. Pilot engineering runs of some key MagTape components are under way. We saw prototype MagTape

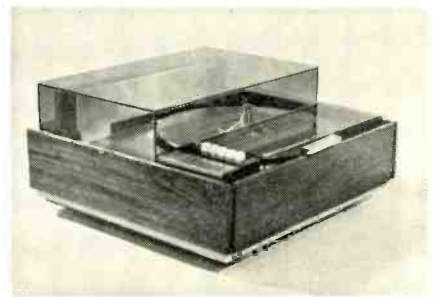

**MYLAR DISCS** are the medium used in MCA's Disco-Vision. Laser scanning cuts record wear.

models and they were impressive. We saw the system function in a variety of ways, and operate through five different brands of TV sets. The recorded picture quality of MagTape was virtually indistinguishable from original off-the-air broadcasts and air-shot dubbings from two-inch broadcast tapes, in terms of color quality, resolution, and brightness. There was no streaking, thanks to a built-in drop-out compensation circuit. The quality of sound was A-1, in both mono and *stereo*—the latter via optional stereo amp and speakers. As for on-the-spot recordings, they came off beautifully.

The target price for a recording deck is \$795, including a one-hour blank cartridge. (A playback-only version will be available at a lower price.) The 35-pound deck measures 24 x 16¼ x 5¾ inches. The cartridge measures 9¼ x 6½ x 1½ inches. The unit records and plays at 3 ips. It runs for one hour on 918 feet of ⅜-inch magnetic tape one-mil thick. Longer lengths will be available. A one-hour cartridge is expected to cost \$29.95. The system uses in-cartridge scanning, with four heads. Tape contacts the headwheel in a 90° wrap (see illustration) as opposed to the 120° or 240° of the omega technique. This approach eliminates threading and reduces strain on the tape, it is claimed. Thus, headlife is longer—about 2,000 hours.

A special feature of MagTape is its ability to record a program via built-in tuner while the user is watching another TV program.

RCA will offer a black-and-white camera as optional equipment, at about \$250. The firm also has a color camera under development, to be offered, hopefully, in 1974. The MagTape system will be marketed by Bell & Howell, and may also appear under the Magnavox brand name. If so, Magnavox will offer a "low-cost" color camera with its version of the concept. MagTape will appear north of the border, bearing the Westinghouse of Canada and Electrohome Limited brand names.

### The Video disc

The Teldec Video Disc mentioned in our last article is still on the way. It will arrive in the U.S. early in 1974. The company actually has production prototypes and has assigned a model number—2001. Some advances have been achieved over the original concept. Now the system offers 10 minutes of playing time in color with stereo sound on an eight-inch disc, versus five minutes for the initial prototype disc. As a result of the playing time extension, the company envisions a somewhat simpler and cheaper automatic changer, at a vague price point under \$400. The greater playing time per disc obviates the need for a very high speed change cycle, a spokesman explained. A single-play deck is expected to sell for around \$220.

The Teldec system uses plastic discs that play at 1,500 rpm (1,800 in the U.S.) Video/sound information is contained in "hill-and-dale" modulations of the disc grooves, rather than the side-to-side, lateral modulation of audio records. A pressure pickup is used. The discs are reproduced through a color or monochrome TV set to which the Video Disc player is attached (via the set's antenna terminals).

With little preliminary fanfare, N.V. Philips of the Netherlands last September debuted its prototype "VLP" (Video Long Play) television disc technique, which will be marketed in the U.S. by North American Philips Co. (Norelco). To be available "in a few years," the concept employs metal vinyl-coated discs and a playback unit using a low-powered (one-milliwatt) helium-neon laser light source instead of a stylus, and an electro-optical pickup which plays the record without direct contact—completely eliminating disc wear. Recording information is in the form of microscopic "pits" rather than grooves as in an audio disc.

### Disco-Vision

A new video disc system from MCA, Inc., Universal City, California, was shown in prototype to a select audience last December. The approach—called "Disco-Vision"—is being refined, with some improvements effected since the initial showing. When will it be on the market? The nearest to a definite statement is that the company hopes to introduce it late in 1974. Target prices for equipment are "under \$400" for a single-play player deck that connects to a TV set (via antenna terminals), and under \$500 for a changer deck that stacks up to 10 discs for a total playing time of 6½ hours, with only four-second change-time

interruptions. Single and multiple disc albums are designed to sell for suggested list prices of \$1.99 to \$9.95 each, depending on content, length and subject.

Disco-Vision employs 12-inch discs made of Mylar .010 inch thick. The discs are metallized to permit handling with no more care than that required for ordinary phono records. They are recorded on one side only. Program material appears in the form of a spiral running from the outer diameter of the discs inward, with a pitch of 80 microinches per revolution. Density is 12,500 tracks per radial inch. The discs revolve at 1,800 rpm and are scanned by a 1mW helium-neon laser. Its beam is electronically steered to follow the spirals; there is no physical contact with the track itself. This technique eliminates record wear and provides unlimited playing life with proper use and handling.

### Software

Software is a major hangup for the VTR industry, what with the variety of formats. Should a film company for example, put out its product in Cartrivision, U-Matic, Omnivision, or VCR form? There is just no way at present to gauge demand, or even interest. According to Stafford Hopwood, head of Videorecord Corp. of America, a national marketing firm for distribution, rental and sales of videoplayers and software, more people are after "special-interest" programming than movies. He said the industry should attempt to market software that fills the special interest needs.

Stafford feels that rentals will be a major element in the software picture since most people will not want to tie up money in programming of limited use-value. He asserted that while people will *listen to* a phono record time after time, they will *look at* a visual presentation only a few times.

What most program production firms and duplicators are doing in the interim (while marketing research goes on, as the various concepts settle in, and as the industry tries to "find itself") is standing by, ready to develop and put out their offerings in whatever form is requested. No company will commit itself exclusively to any one format—primarily as a protective measure to accommodate the vagaries of the marketplace.

The two front-running companies actively marketing cartridge VTR equipment are doing their utmost to see that software is available to feed the equipment. Taking their cue from the audio tape field, they realize that the key to equipment sales is easy and wide availability of pre-recorded VTR cartridge tapes.

Sony, for example, with some 20,000 U-Matic units in the U.S. and Canadian markets, and expectations of selling another 100,000 world-wide this year, tells prospects as well as actual purchasers that there are over 2,000 programs available in U-Matic form. They can be bought or rented. These are from over 40 film producers and program suppliers, including Time, Inc. There are at least six U-Matic tape duplication centers around the country.

Cartrivision, currently offering some 300 pre-recorded programs, is producing additional titles at a claimed rate of 200 per month. The company has access to some 4,000 titles, including 2,000 major films

from several film libraries. The film cartridges are for rent or purchase. Rental charges range from \$3 to \$7 per play, depending on program length, content, and other variables. Purchase prices range from \$12.98 to \$39.98 for pre-recorded cartridges running from 15 to 114 minutes. Rentals are through Cartridge Rental Network, a joint venture of Columbia Pictures and Cartridge Television Inc.

### What does it cost?

What's going to happen to VTR equipment prices? That's a question being pondered in the industry. The reasoning is that as more machines come into the market, the greater will be future demand, based on the initial "seeding" process. As companies amortize some of their tremendous R & D

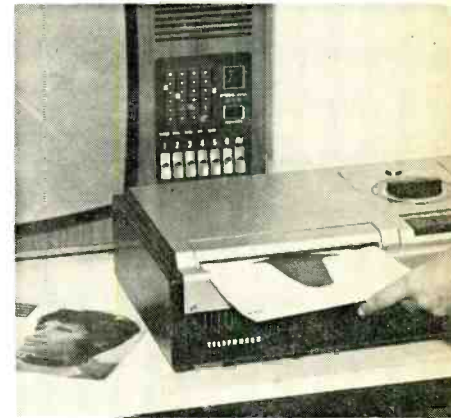

TELEFUNKEN TELDEC video disc and player are shown here. Disc and protective sleeve are inserted into player.

expenses, and as competition increases, the belief is that prices will come down. This has been the pattern for the entire home electronics business, ever since the twenties when radio came on the scene in a big way.

Currently there is speculation that Sony will bring out a U-Matic record/play deck priced around \$800, and that Cartrivision will have one at that price also . . . to offset possible competition from RCA's upcoming MagTape machine in that price range. In effect, both Sony and CTI will be protecting their initial strong market positions—as well as their colossal investments in achieving those positions—by introducing \$800 units.

The lowest priced color TV camera now available is Magnavox's "Chromavue 400" at \$2,500 list. But the company is working on a derivative of that unit which it hopes to sell for "under \$1,000", possibly in mid-1974. Other companies are also known to be working on low-priced color video cameras.

The price range for most one-hour blank video tapes is \$33 to \$40. But this range will drop as the industry expands and more machines enter the marketplace. Several audio tape firms have moved into the video field, and others plan to follow. One firm, Audio Magnetics, has as its goal the production of a high-quality video tape in cassette form, at a price under \$10.

Irish Magnetic Tape has a line of quarter-inch video tape for Akai VTR's in 30 to 120-minute lengths, at \$9.95 to \$49.95. Ampex has a one-hour tape for Akai equipment at \$20. **R-E**

# 11 ways to with your

*IC's cease to be mysterious black-boxes  
test instruments as a FET multimeter.*

VARIOUS TESTS OF INTEGRATED circuits can be made with conventional vom's or tvm's. However, the high-low (hi-lo) FET meter has a distinct advantage because resistance measurements can be made with a low value of applied test voltage. This test voltage is so low that a normal junction cannot be "turned on" by a resistance measurement.

Practically, this means that all of the transistors and diodes in an integrated circuit are effectively absent when a hi-lo FET meter is operated on its (LOW-POWER OHMS) function. In turn, resistors can be checked out accurately, and various semiconductor junctions can be checked for leakage. Although not all IC's can be completely checked out, many practical tests can be made.

Here are 11 ways to use your hi-lo FET meter to test comparatively simple IC's with a small number of built-in transistors, resistors, and diodes. (If you wish to test large-scale IC's with many built-in transistors, more elaborate test procedures must be used.

## 1. CHECKING RESISTORS

**Equipment:** Hi-Lo FET meter.

**Connections:** Connect ohmmeter test leads to IC terminals, as in Fig. 1.

**Procedure:** Set meter controls to measure low-power ohms. In the example in Fig. 2, measure resistance values between terminals 4-9, 4-10, and 5-10.

**Evaluation:** Because the resistance measurements were made on the LOW-POWER OHMS function, our equivalent circuit is shown in Fig. 3. The 4-9 measurement is the resistance of  $R_1 + R_3$ , or 6K. The 4-10 measurement is the resistance of  $R_2 + R_3$ , or 6K. The 5-10 measurement is the resistance of  $R_4$ , or 18K. If substantially different resistances are found, reject the IC.

**Note:** Although other pairs of terminals could be used to measure resistance in Fig. 3, this would provide no additional information. That is, there are four resistors in the circuit, each of which is included at least once in the 4-9, 4-10 and 5-10 measurements. Or each resistor could be measured alone.

## 2. CHECKING THE TRANSISTORS IN AN IC FOR LEAKAGE

**Equipment:** Hi-Lo FET meter.

**Connections:** Same method as test 1.

**Procedure:** Set meter controls to measure low-power ohms. Referring to Fig. 2, measure the resistances between terminals 6-8, 1-2, 1-8 and 1-9. The  $R \times 1$ -MEG range provides the most sensitive test.

**Evaluation:** The resistance measurements were made on the LO-PWR OHMS function. So our equivalent circuit is shown in Fig. 4. All junctions are normally open circuits in this test, and the meter should read infinity in the foregoing tests. If resistance readings are substantially less than infinity, reject the IC.

**Note:** Junctions do not normally "turn on" when the low test voltage of the LO-PWR OHMS function is applied. Therefore, the polarity of the test voltage is of no concern. If a junction is leaky or shorted, a resistance reading of less than infinity will be observed, regardless of the test-voltage polarity.

## 3. CHECKING A DIODE IN AN IC FOR LEAKAGE

**Equipment:** Hi-Lo FET meter.

**Connections:** Same as in test 1.

**Procedure:** Set meter controls to measure low-power ohms. Referring to Fig. 2, measure the resistance value between terminals 3-4. The  $R \times 1$ -MEG range pro-

vides the most sensitive test.

**Evaluation:** Because the resistance measurement is made on the LOW POWER OHMS function, the meter should read infinity. If the resistance reading is substantially less than infinity, reject the IC.

**Note:** A diode junction is basically the same as a transistor junction, and is tested in the same manner. The diode junction is normally an open circuit on the LO-POWER OHMS function, regardless of the polarity of the applied voltage.

## 4. CHECKING THE SUBSTRATE IN AN INTEGRATED CIRCUIT FOR LEAKAGE

**Equipment:** Hi-Lo FET meter.

**Connections:** Same as in test 1.

**Procedure:** Set meter controls to measure low-power ohms. Referring to Fig. 2, measure the resistance value between terminal 7 and any other terminal of the IC. The  $R \times 1$ -MEG range provides the most sensitive test.

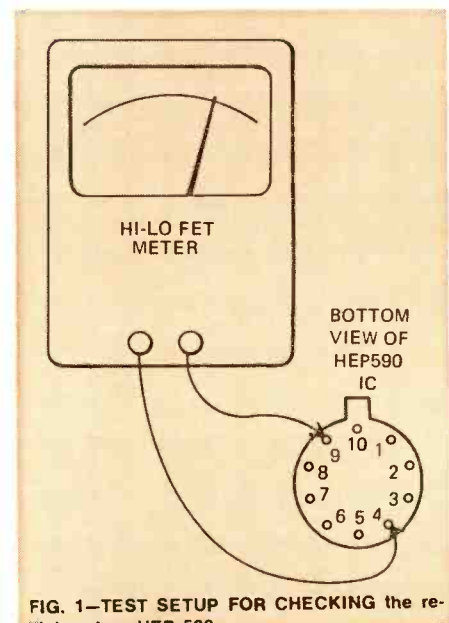

FIG. 1—TEST SETUP FOR CHECKING the resistors in a HEP 590.

# test IC's FET VOM

when you can check them with such basic

Here are 11 ways you can test an IC

by ROBERT G. MIDDLETON

**Evaluation:** Because the resistance measurement is made on the LOW-POWER OHMS function, and the substrate effectively presents a junction to other IC terminals, the meter normally reads. If we find a resistance reading substantially less than infinity, reject the IC.

## 5. CHECKING THE FRONT-TO-BACK RATIO OF TRANSISTORS IN AN INTEGRATED CIRCUIT

**Equipment:** Hi-Lo FET meter.

**Connections:** Same as in test 1.

**Procedure:** Set meter controls to measure high-power ohms, and operate on the  $R \times 100$  range. Referring to Fig. 2, measure the resistance between terminals 2 and 1. Then, reverse the test leads and measure the resistance between terminals 2 and 1 again. Repeat the pair of measurements for terminals 6 and 8.

**Evaluation:** These tests are essentially the same as out-of-circuit front-to-back ratio measurements. Normally, the forward resistance will measure somewhat more than 1000 ohms, and the reverse resistance will measure infinity. A substantially incorrect front-to-back ratio indicates a defective integrated circuit.

**Note:** The diode in Fig. 2 can be tested similarly for front-to-back ratio between terminals 3 and 4. Test 5 yields the front-to-back ratio for the collector junction of Q2 and the emitter junction of Q3. No data has been obtained concerning the front-to-back ratio of the remaining junctions.

## 6. CHECKING THE FRONT-TO-BACK RATIO OF A TRANSISTOR SHUNTED BY RESISTANCE

**Equipment:** Hi-Lo FET meter.

**Connections:** Same as in test 1.

**Procedure:** Set meter controls to measure high-power ohms, and operate on a suitable resistance range. In this example, we will employ the  $R \times 100$  range. Referring to Fig. 2, measure the resistance between terminals 9 and 10. Then, reverse the test leads and measure the resistance again.

**Evaluation:** The equivalent circuit in this test is for all practical purposes shown in Fig. 5. Normally, we measure somewhat more than 1000 ohms in the forward direction and 6000 ohms in the reverse direction. Since 6000 ohms is considerably larger than the normal forward resistance of the collector-base junction, the practical measurement of forward resistance compares to that in test procedure 5. However, the measurement of reverse resistance is established by the 6000-ohm shunt; therefore, this is an incomplete test.

## 7. CHECKING THE FRONT-TO-BACK RATIO OF A TRANSISTOR WITH SERIES RESISTANCE

**Equipment:** Hi-Lo FET meter.

**Connections:** Same as in test 1.

**Procedure:** Set meter controls to measure high-power ohms, and operate on a suitable resistance range. In this example, we will use the  $R \times 100$  range and check the front-to-back ratio of Q2. Referring to Fig. 2, measure the resistance between terminals 4 and 6. Then, reverse the test leads and measure the resistance between terminals 4 and 6 again.

**Evaluation:** The equivalent circuit in this test is shown in Fig. 6. Normally, we will measure approximately 3,500 ohms in the forward direction and infinity in the reverse direction. Since 3,000 ohms

*(continued on page 78)*

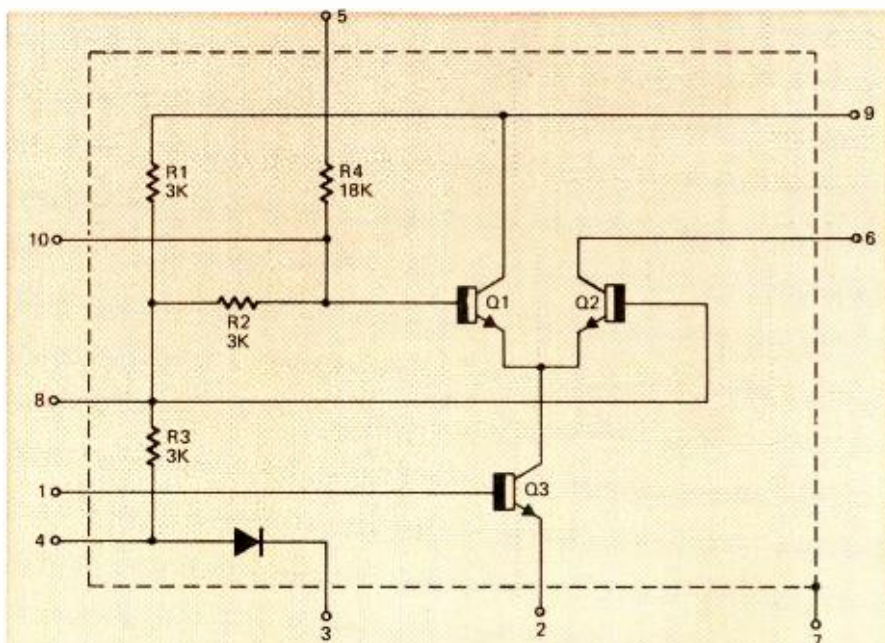

FIG. 2—COMPLETE CIRCUIT of Motorola's HEP 590 IC. Tests between various terminals indicate the condition of the resistors and the semiconductors

# 4-CHANNEL SQ LOGIC

## *a closer look at how it works*

THE WAR OF THE FOUR-CHANNEL DISCS has resolved itself into two well-defined camps. Columbia Records continues to champion its matrix SQ system. Judging by the number of SQ discs now available and the relative intercompatibility between this particular matrix approach and earlier matrix proposals espoused by Electro-Voice and Sansui, CBS certainly assumes the role of "chief spokesman" for matrix discs in general.

RCA has assumed the role of the "latecomer" with its "discrete" disc and inherently more complex demodulation requirements and a notable absence of records available to the consumer. We are assured, however, that discrete discs will soon abound and that, indeed, RCA intends to catch up and surpass SQ achievements in a short time.

In the meantime, decoder circuits for SQ discs are becoming more and more sophisticated and such terms as "front-back logic" and "wave comparator circuitry" are being added to an already growing lexicon of four-channel terminology. A great deal has been written about the SQ matrix system, much of it slanted towards an understanding of the record groove itself, rather than the signal components expressed in a manner more easily understood by the electronics fraternity. To understand the SQ system and the subsequent logic-circuitry which is being added to it to enhance separation, it would be worthwhile to take another look at SQ, in terms of actual signal make-up and without resorting to the vague and nebulous references to "four kinds of groove modulations" (lateral, vertical, and two directions of "helical") which have been referred to in the past.

All matrix systems can be expressed by generalized equations for both the encoding and the decoding processes. In the case of encoding:

$$L_t = AL_f + BR_f + CL_b \angle \theta + DR_b \angle \beta \text{ and}$$

$$R_t = AR_f + BL_f + CR_b \angle \theta + DL_b \angle \beta$$

in which  $L_t$  and  $R_t$  are the composite, encoded left and right signals which are actually recorded as two conventional stereo channels in the normal manner.  $L_f$ ,  $R_f$ ,  $L_b$  and  $R_b$  are the left-front, right-front, left-back and right-

back discrete four channel signals. A, B, C and D are coefficients having some value between "0" and "1" and angles  $\theta$  and  $\beta$  are phase shift angles between "0" and "180" degrees and may be either "leading" or "lagging" with respect to the original, discrete signals. In the case of the CBS-SQ encoding parameters, coefficients A, B, C and D are chosen to be 1, 0, -.707 and .707 respectively while angles  $\theta$  and  $\beta$  are chosen to be  $90^\circ$  and  $0^\circ$  respectively. Thus, to express the contents of the two composite signals in the SQ system, we may say that:

$$L_t = L_f - j.7L_b + .7R_b \text{ and } R_t = R_f - .7L_b + j.7R_b$$

(0.707 has been rounded off to 0.7 for simplicity in transcribing). The vector diagrams of Fig. 1 show the signal

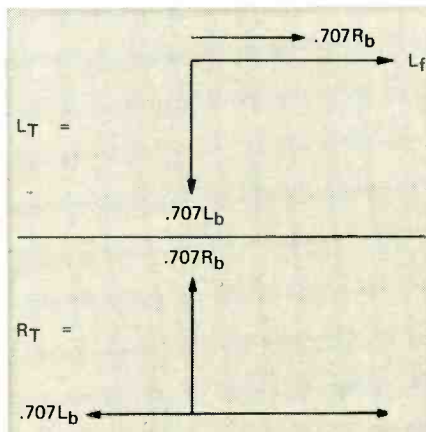

FIG. 1—AMPLITUDE AND PHASE relationships of SQ encoded  $L_t$  and  $R_t$  composites.

contents for each of the composite signals indicating amplitudes as well as angular displacement, where an arrow pointing to the right means  $0^\circ$  of the phase shift while arrows pointing up and down denote positive and negative phase shifts of  $90^\circ$  respectively.

The decoding formulas chosen by CBS in the SQ system are:

$$L_f' = L_t; \quad L_b' = -.707(-jL_t + R_t)$$

$$R_f' = R_t; \quad R_b' = .707(L_t - jR_t)$$

If we substitute the values for  $L_t$  and  $R_t$  established in the two encoding equations shown earlier, we can derive the values of the recovered four channels of output in terms of the original discrete input signals. None of the descriptions of this system which have appeared in print bothered to take the equations through this impor-

tant, final step. The results obtained after going through the extra algebra are:

$$L_f' = L_f - j.7L_b + .7R_b;$$

$$R_f' = R_f - .7L_b + j.7R_b;$$

$$L_b' = L_b + j.707L_f - .707R_f;$$

$$R_b' = R_b - j.707R_f + .707L_f$$

These results really explain the "design philosophy" inherent in the SQ system. Notice that for the recovered front channels, there is complete absence of  $R_f$  content in the  $L_f'$  recovered signal and complete absence of  $L_f$  in the  $R_f'$  recovered signal.

As for the back channels, the same "total separation" holds true. That is, there is no  $L_b$  content in the output of the  $R_b'$  channel and there is no  $R_b$  signal in the  $L_b'$  output. It is this effect which enables CBS to claim "full" side-to-side separation in their system. Furthermore, since stereophonic playback involves the repro-

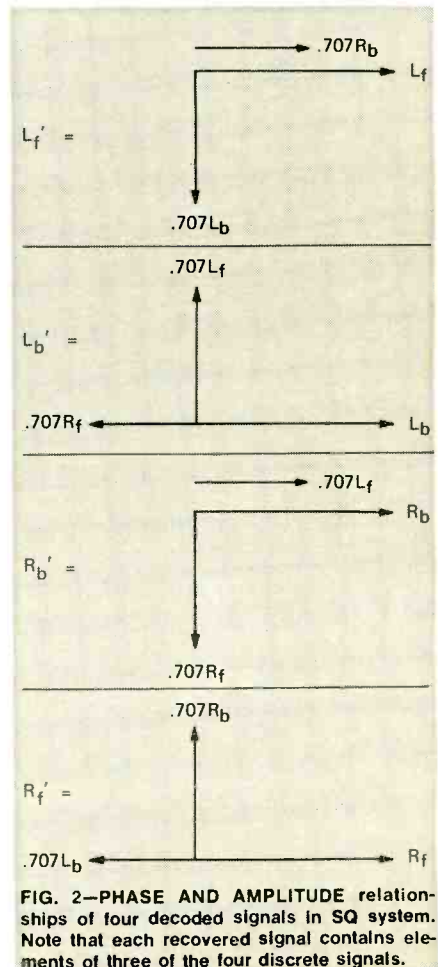

FIG. 2—PHASE AND AMPLITUDE relationships of four decoded signals in SQ system. Note that each recovered signal contains elements of three of the four discrete signals.



Columbia Record's SQ matrix system is pressing to become the quadriphonic disc standard. Here's what it's all about.

by LEONARD FELDMAN  
CONTRIBUTING HIGH FIDELITY EDITOR

duction of the  $L_f$  and  $R_f$  composite signals with *no* decoding, full left-front to right-front separation is maintained in two-channel playback as well, since the  $L_f$  and  $R_f$  signals are not "cross-blended" in the encoding process either. The vector diagrams shown in Fig. 2 again display the signal content of each of the four output channels in a simple SQ matrix decoder and illustrate amplitude as well as phase relationships of the *three* signal components which are heard from each loudspeaker.

Offsetting this excellent side-to-side separation capability are crosstalk effects from front to rear and across diagonals which are quite severe. The equations for each recovered channel clearly show that while the desired program channel dominates in level, two of the three remaining unwanted channels are present, and attenuated a mere 3 dB (0.707 in amplitude equals -3dB compared to "1" or unity). Chief criticism of the "simple matrix" decoders designed for SQ is their inability to provide good "front-back" separation, particularly when a soloist or vocalist is supposed to be up front and "center stage."

Normally, when that effect is desired, equal amplitudes of the vocalist's "signal" are fed to the front-left and front-right channels in normal two channel recordings. Upon playback, an apparent image is created between the two front speakers, since each speaker is producing the same sound at the same level. Translated to quadriphony, a recording engineer would have to apply the "C" (for "center") signal as the only contribution to the  $L_f$  and  $R_f$  signals during the encoding process. Let us assume that no other channels contain signals for the moment. Then  $L_f = C = R_f$  and if we substitute C for  $L_f$  or  $R_f$  in the four expanded decode equations we would obtain:  $L'_f = C$ ;  $R'_f = C$ ;  $L'_b = j.707C$  and  $R'_b = .707C$ . This means that the rear channels, which should have had *no* center vocalist present, are only 3 dB lower in sound than are the front channels for a condition of "center vocalist."

#### Front-back logic

Illustrated in Fig. 3 is Sony's model SQD-2050 SQ decoder. This

unit, in addition to providing the necessary matrix decode circuitry, features additional circuitry known as "front-back" logic. The exact workings of the logic circuitry have not been disclosed to date, but essentially the "dominance" of a front signal is detected by the circuitry and variable-gain amplifiers are so biased that if a front signal predominates, the gain of the rear amplifiers is reduced. Similarly, if back signals predominate instantaneously, the gain of the front output amplifiers is reduced.

The resulting available front-back separation capability of the model illustrated is approximately 10 dB (as opposed to the inherent 3 dB of the basic matrix system), but it should be emphasized that *no* gain riding system, however complex, can compensate for *all* possible musical combinations that are likely to occur. For example, if, at a given instant, equal amplitude signals from various instruments are in-



FIG. 3—SONY SQD-2050 DECODER features logic circuits to enhance the otherwise poor front-to-back separation of the SQ system.

tended to be heard from all four loudspeakers (a different instrument from each—but all playing at approximately equal volume), no logic system yet conceived can isolate the channels completely and, under those unique circumstances, no "gain riding" takes place and separation reverts to the 3 dB which is inherent in the SQ system.

Figure 4 is a reproduction of one of the diagrams included in Patent No. 3,708,631 issued by the U.S. Patent Office to CBS. In this early first patent, it will be noted that the four loudspeakers shown are arranged

### about the author



Leonard Feldman, well-known author, lecturer and engineer consultant in the high-fidelity field, has been appointed Contributing High-Fidelity Editor of **Radio-Electronics Magazine**.

Author of numerous books and articles on audio and frequency modulation, Feldman's technical experience includes work as a project engineer on audio and FM product development and participation in the FCC field trials, which led to the approved system for stereo FM broadcasting. Active in quadriphonic sound development, he is coinventor of a matrix four-channel system. A former components manufacturer, Mr. Feldman operates his own consulting engineering firm, serving hi-fi manufacturers in the U.S. and abroad.

Feldman is also technical advisor to the Institute of High Fidelity, an organization of more than 50 leading manufacturers of hi-fi components. As chairman of the IHF's new standards committee, he is helping establish standards for rating hi-fi equipment. He is a member of the IEEE and the Audio Engineering Society.

as "front," "back," "left" and "right" systems, the so-called "diamond" pattern which was popular in the early days of quadriphonic experimentation. For this reason, an explanation of the "logic" portion of this circuit (enclosed by dotted lines) would not conform to the gain riding requirements of today's more popular "square" speaker configuration.

Nevertheless, the illustration is reproduced here merely to show the relative complexity of these "logic" circuits and the number of active amplifying stages needed if discrete components are used. The particular diagram represents only one degree of logic, in that gain of front and back speakers will be reduced when either a left or right signal predominates, while gain of left and right channels will be reduced when either a front or back channel predominates. If this system were translated (by proper adjustment of parameters and the necessary phase shifting networks) to work with square speaker configurations, it would approximate the "front-back" logic circuitry of the Sony Model 2050.

Even more complex logic circuitry is used in such models as Sony's SQD-2020 (pictured in Fig. 5), in which front-back logic is augmented by what the company calls "wave comparator" logic circuits which reduce ambiguities along the sides of the listening room. Such "two-level" logic circuits are considerably more complex than the circuit shown in Fig. 4 and the number of amplifiers and other active circuits is considerably greater.

### IC's for SQ

Happily, the progress made in large-scale integration for IC's prompted Motorola to develop a family of IC's which can reduce cost and simplify construction of SQ matrix decoders. The first of these decoder "chips," Motorola's XC-1312P, has been available for some time and its use in SQ matrix decoding is shown in block diagram form in Fig. 6. Actual external components used to affect the necessary 90° phase shifts are shown in the complete schematic diagram of Fig. 7 and 5% tolerance capacitors and resistors are recommended to insure accurate phase shift characteristics.

Note, that in the absence of further logic circuitry, the manufacturer shows two "blend" resistors (7.5K and 47K marked by asterisks) that may be added to the circuit to improve front-back separation. Addition of these two resistors, however, will result in less-than-perfect separation between left-front and right-front, or between left-back and right-back. As with all matrix circuits, you cannot have the best of both kinds of separation at the

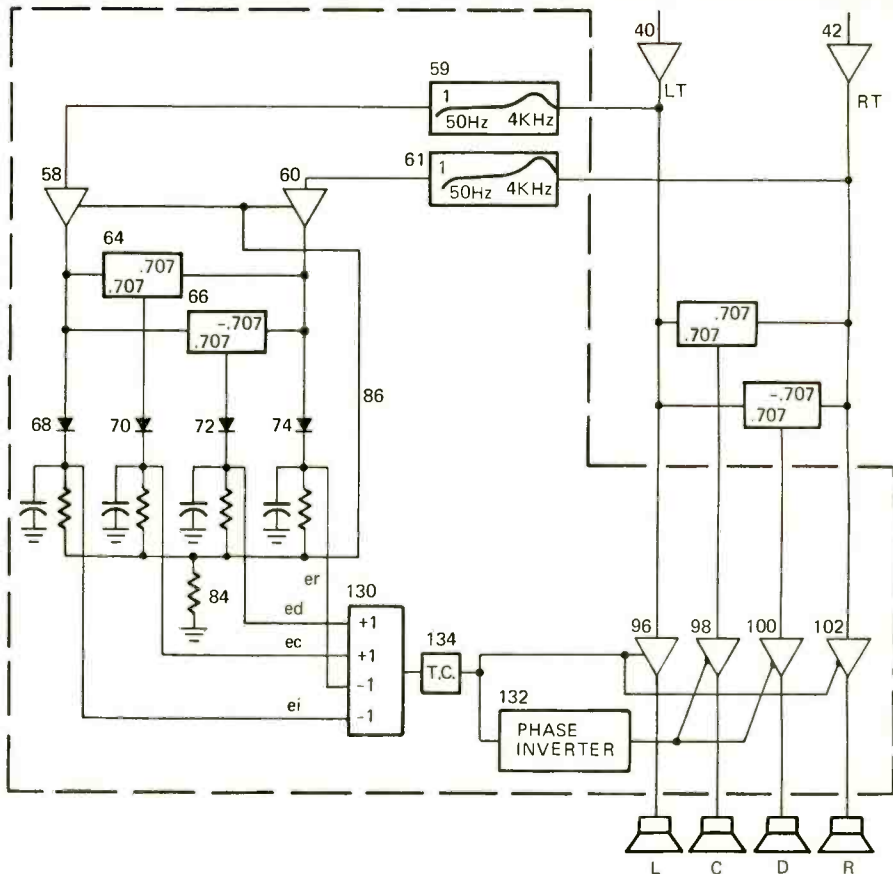

FIG. 4—SIMPLE LOGIC SYSTEM in CBS patent. Items 40, 42, 58 and 60 are amplifiers; 96, 98, 100 and 102 are gain-controlled amplifiers and 130 is a summing amplifier. Resistor 84 averages the dc voltages from rectifiers 68-74. Items 64 and 66 are separators; 59 and 61 are response weighting networks. Time-constant 134 fixes the logic attack time.

same time and the use of these "blend" resistors constitutes a form of trade-off when only the simple matrix decoder circuit is used.

Working closely with CBS, Motorola has developed two more IC's which, when added to the unit shown in Figs. 6 and 7, provide "full logic" decoding for the SQ system. The additional "chips" are identified as MC-1314 and MC-1315. The first of these constitutes the necessary voltage or gain-controlled amplifiers, while the second serves as the logic control circuits.

A complete suggested interconnecting diagram is shown in Fig. 8 and, because voltage-gain controlled amplifiers are used, certain side benefits accrue. A single-section potentiometer can be used to control overall gain of all four channels while other single-element potentiometers can control overall front-back balance, left-right front balance and left-right back balance.

In addition, connected to pin 13 of the MC-1315 logic-control IC is a fifth control which is identified as a "dimension" control. This last control enables the user to adjust the amount of logic action for best performance in his own listening room or to select varying amounts of logic control de-



FIG. 5—WAVE COMPARATOR used in this and other expensive decoders has front-back and slide-to-side logic circuitry.

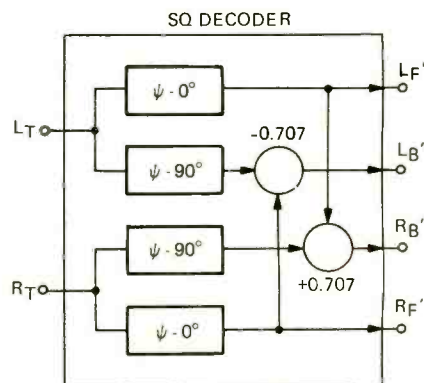

FIG. 6—BLOCK DIAGRAM of Motorola XC-1312P IC chip for use in SQ matrix decoding. The required external parts are shown in Fig. 7.

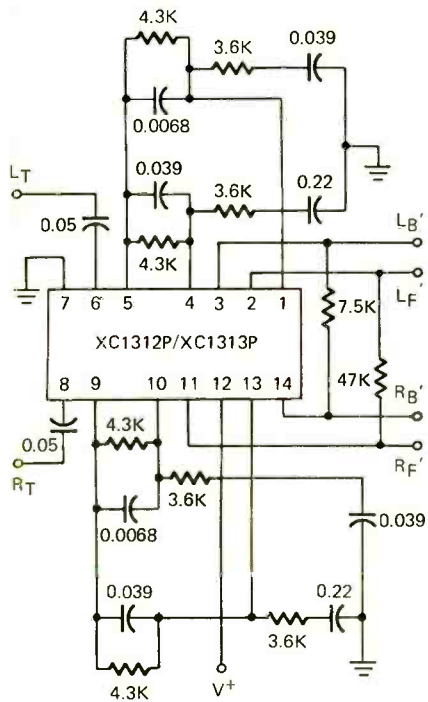

FIG. 7—SQ DECODER using Motorola IC. Blend resistors (7500 and 47,000 ohms) are connected between the  $L_B$  and  $L_F$  and  $L_F$  and  $R_F$ .

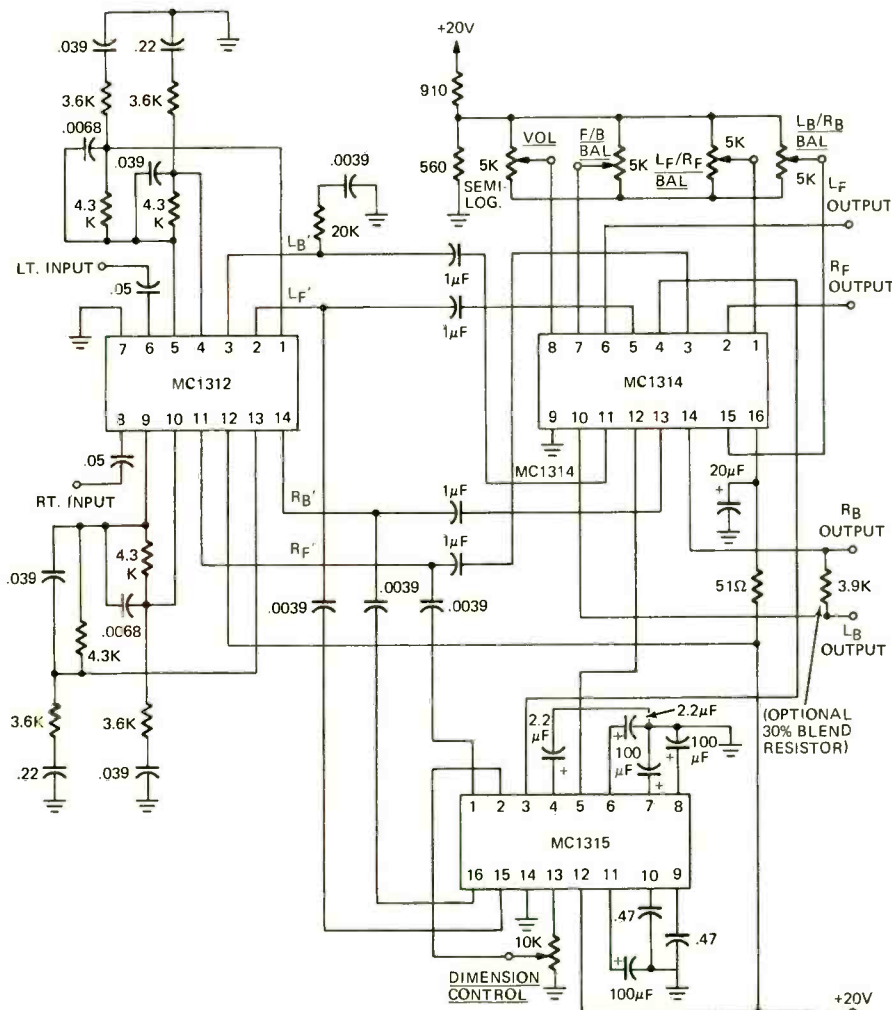

FIG. 8—FULL LOGIC DECODING is made possible by adding two new Motorola IC's to the circuitry in Figs. 6 and 7. The MC1314 has the gain-controlled amplifiers while the MC1315 serves as the logic control elements. The "dimension" control lets the listener adjust the logic circuits for his listening area and for the SQ disc being played.

pending upon the particular SQ disc being played.

Using the entire system of 3 IC's, nominal input level is 0.5 volts at a total harmonic distortion out of the system of approximately 0.1%. Signal-to-noise ratio quoted for the system is 80 dB and voltage gain is unity. External components required for the complete system comes to 28 capacitors and 8 resistors (not including the single-section potentiometers referred to earlier).

At the present time, total-logic decoders such as the Sony SQD-2020, sell for well over \$200.00 because discrete transistors are used in the logic circuitry. It is conceivable that within a few months, however, when the Motorola family of SQ IC's becomes available, prices of decoders should come down substantially. If, in fact, the price of a full-logic decoder comes down to around the \$100 mark, that would be competitive with the first RCA "discrete" Quadradisc demodulators being offered.

Such a development will make the "battle" between the two record

giants even more interesting. In terms of realizable instantaneous separation, Sony claims 20 dB from  $L_f$  to  $R_f$ ,  $L_f$  to  $L_b$  and  $R_f$  to  $R_b$ . Center-front to center-back has been improved to 15 dB separation on the full logic product. These numbers compare very favorably with those obtained in the so-called "discrete" system, although it should be emphasized that they represent "instantaneous" or apparent separation and even the "double logic" system can be fooled ("confused" would be a better term) when certain combinations of four-channel programming occur.

Against this relatively minor disadvantage (most music does have instrumental emphasis of one sort or another most of the time), there is the rather tricky cartridge requirement of the competing "discrete" disc system which requires reasonably good response out to 45 kHz. Add a replacement cartridge to that nominal \$100 for discrete four-channel disc capability and you may, perhaps, offset the total discreteness of the Quadradisc.

Actually, it's not necessary to vote for either system at this point. Clearly, both are going to coexist for the foreseeable future—much as the 45 rpm record coexists with the 33 $\frac{1}{3}$  rpm LP. In future articles we'll delve into some of the ramifications of converting to Quadradisc four channel capability—just to be completely fair! **R-E**

## SOLID STATE NEWS

National Semiconductor Corporation (2900 Semiconductor Drive, Santa Clara, Calif. 95051) has released a new series of 3-terminal negative power regulators. The new devices, designated the LM120 series, will supply up to 1.5 amperes at 20 watts dissipation. Each IC is completely self-contained, featuring preset output voltage, internal overload protection, and thermal limiting for fail safe operation. Output voltages of -5, -5.2, -12, and -15 volts are available with an accuracy of  $\pm 2\%$ . Load regulation is typically 30 mV at 1 A, and ripple rejection is better than 60 dB. Only one external component, a compensation capacitor across the output, is required for LM120 operation. The new devices are available in both TO-3 and TO-5 packages.

Fighting inflation, Fairchild's Microwave and Optoelectronics Division (464 Ellis St., Mountain View, Calif. 94040) has announced across the board price reductions in its line of LED's, with reductions of up to 60 percent in large quantities of some units. Fairchild's FLV110, for example, has been reduced from 58¢ to 33¢ in 1,000 up quantities, and down to 17¢ each in 100,000 up lots.

# SPEED TROUBLESHOOTING

Part III of a series introducing efficient troubleshooting and

by JONATHAN L. TURINO

IN THE FIRST TWO PARTS OF THIS series we developed a method of logical and efficient troubleshooting called "cut-it-in-half" troubleshooting (*Radio Electronics*, April and May 1973.) Before giving the answers to last month's quiz and the reasons for them, here's a brief review of the tenets developed in the science of logical troubleshooting.

Two things are necessary for logical troubleshooting—hardware and software. The hardware is your test equipment. You must have the right piece of test equipment for the job. The software includes your knowledge, any theory of operation and operating instructions, and most importantly, a block diagram of the equipment to be repaired. Once all of these things are at hand, troubleshooting begins by checking the simple things first, and then using all available information to proceed logically to find a defective component. With all of this in mind, let's look at the answers to last month's tape recorder troubleshooting quiz. From the symptoms given, the trouble was not in the playback section. The first answer should be point "C", the auxiliary input. This is the first logical check since it eliminates the microphone preamp and the record preamp. The second choice should have been point "D", the halfway point between the auxiliary input (known signal) and the output from the head. The third answer was "3"—the trouble is in the record amplifier, and that is where we should troubleshoot.

If you had a problem answering the tape recorder quiz correctly, it might be a good idea to review some of the things discussed earlier in this series. Being an expert troubleshooter takes a little study, but it is worth the effort even if you limit your repair work to your own home entertainment equipment.

A great deal of emphasis has been placed on the use of the block diagram for troubleshooting. The main reason for this emphasis is that with a block diagram, and some knowledge of what a piece of equipment should do, you can troubleshoot even the most complex gear, even when you are unfamiliar with how it functions internally. With the block diagram you can analyze how each section and stage in almost any piece of equip-

ment operates. Once you have analyzed it, you will be able to troubleshoot—if you proceed in a logical fashion.

Fig. 1 shows the functioning blocks of a digital counter. Since a digital anything (voltmeter, ohmmeter, thermometer) operates almost exactly the same way (the input parameter to be measured is converted to frequency by a separate "block"), once you can troubleshoot the basic counter, you are well on your way to being able to re-

pair almost anything digital.

The counter is composed of several interconnected functions. The oscillator creates a stable frequency used as a time standard. The dividers, together with the range switch, determine how long the gate block allows the input signal (conditioned by the input signal conditioning block) to be fed to the divide-by-2 stages. The divide-by-2 stages start out reset to zero, and if eleven pulses come through when the timing dividers provide a one second

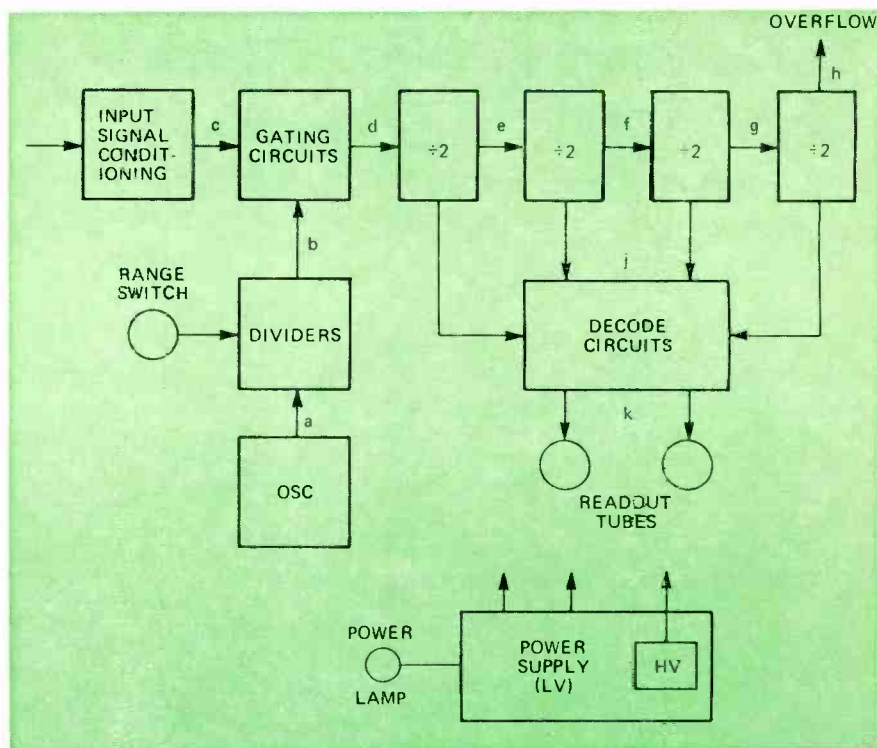

FIG. 1—BLOCK DIAGRAM of a digital frequency counter shows how easy it is to troubleshoot electronic devices when you break them down into functioning and nonfunctioning circuits.

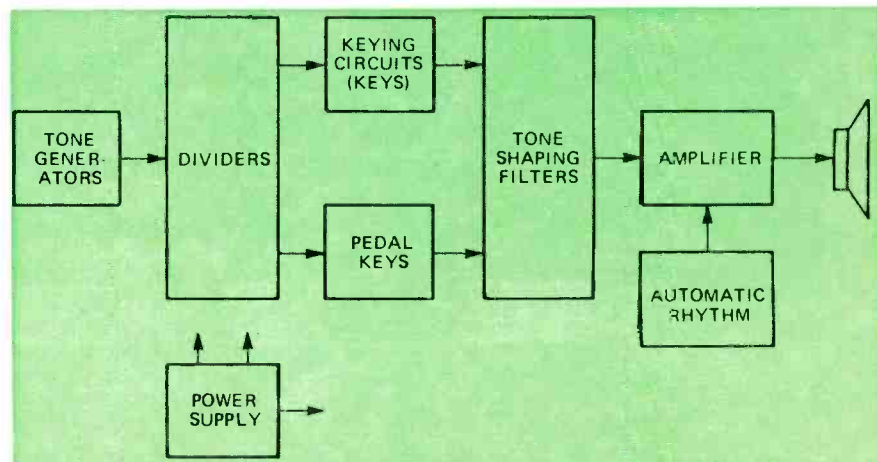

FIG. 2—ELECTRONIC ORGAN is illustrated by this block diagram. Each of the eight major sections can be broken into smaller blocks as troubleshooting brings you closer to the defect.

# With A Logical Approach

a novel approach to speedy and repair of electronic gear

gate, the divide by 2 stages are set to  $1011_2$  by the eleven pulses. The decode block converts the binary number 1011 to a decimal number and

causes the readouts (Nixie tubes, segment indicators, or any other digital readout device) to display it. If the timing dividers provide a 0.1 second

gate and twelve pulses are counted by the divide by 2 stages, 120 Hz is the frequency of the input signal. You can see that even an expensive and complex device such as a digital counter can be broken down into easily understandable "function blocks."

How about troubleshooting this counter? Here are a few examples of how cut it in half troubleshooting can be applied. See if your diagnosis matches ours, and be sure that you can see the reasoning behind the diagnosis.

**Symptom 1**—The power lamp comes on, but the readout tubes will not light up (even on "00"). **Defective stage**—The readout tube section of the power supply is the most likely, although the "decode" block could be responsible. Check the power supply first.

**Symptom 2**—The number "00" is continuously displayed. **Defective stage**—There is no simple answer here, we have to troubleshoot. Just looking at the block diagram, point "d" looks like it is about the halfway mark in the counter. Suppose we find that the signal is not coming out at point "d." Where do we check next? The gating circuits are fed by two things—the timing dividers and the input signal conditions. Either place is good for your next check. If the input signal is present at point "c", check point "b." If both signals are present, it is obvious that the gating circuits stage is defective.

Troubleshooting this way is not only simple, it is fun. Treat every troubleshooting job as a challenge, a battle of wits between you and the electron, and you will excel at it.

Fig. 2 is a modern electronic organ. Most of the functions are self explanatory so there is no accompanying "theory of operation." You can't fix an organ? One further rule when troubleshooting—think positive. You can if you take the time to sit down and study the block diagram of something, or better yet, create your own block diagram from the schematic. There is nothing that you can not troubleshoot. Even though the electronic organ in Fig. 2 can cost from \$500 to \$5,000 and may have several thousand parts, it has only seven major functions. Isolate to the function. Each of the large blocks has several internal blocks. Sectionalize to isolate the big block, and

(continued on page 96)

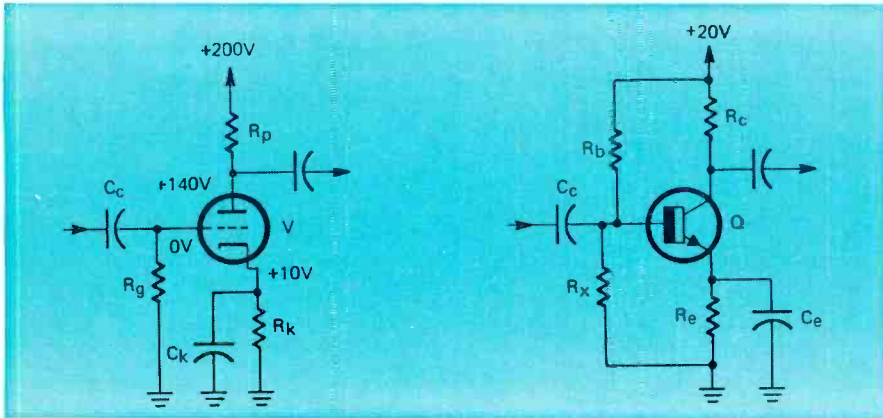

$E_p$	$E_g$	$E_k$	DEFECTIVE COMPONENT
140V	0V	10V	(NORMAL)
0V	0V	0V	$R_p$ OPEN
200V	0V	150V	$R_k$ OPEN
100V	0V	0V	$C_k$ SHORTED
100V	20V	20V	$C_c$ LEAKY
200V	0V	0V	V (THE TUBE)

$V_c$	$V_b$	$V_e$	DEFECTIVE COMPONENT
12V	2.6V	2.0V	(NORMAL)
2V	2V	2V	Q SHORTED
20V	2.6V	0V	Q OPEN
20V	2.6V	2.6V	$R_e$ OPEN
6V	0.7V	0V	$C_e$ SHORTED
6V	4.6V	4V	$C_c$ LEAKY

FIG. 3—TUBE AND TRANSISTOR AMPLIFIERS (left and right, respectively) are typical of those in functioning circuits. The chart readings pin-point the defective component.

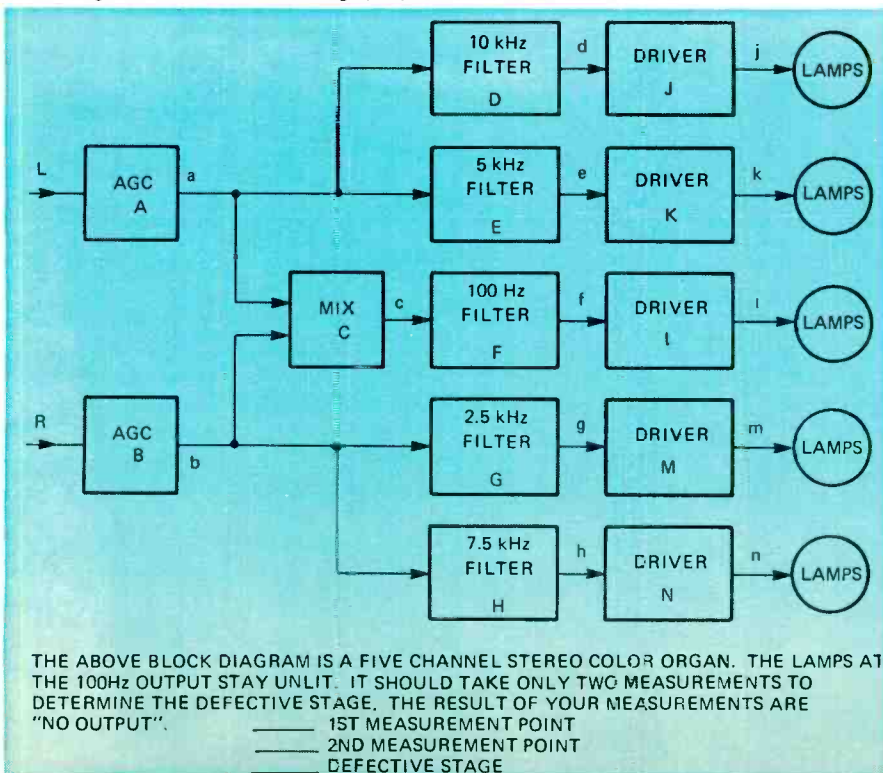

FIG. 4—TEST YOUR KNOWLEDGE of the logical troubleshooting technique covered in this series by localizing defective stage in this color organ. Answer appears next month.

# STATE-OF-SOLID-STATE

A UNIQUE METHOD OF FM DETECTION using a new linear gating technique is featured in a monolithic integrated circuit now available from Signetics (811 East Arques Ave., Sunnyvale, Calif. 94086). Designated type ULN2111, the new device is intended for applications in TV audio channels, FM receivers, afc systems, and communication receivers, but also can be used in more sophisticated circuitry in telemetry receivers, automatic control systems, and servo amplifiers.

As illustrated in Fig. 1-a, the new device comprises 18 npn transistors, 6 diodes, and 18 resistors making up two functional circuits, a limiter/amplifier and a detector/amplifier. The two functional circuits are interconnected by a simple external phase-shift network, as shown in Fig. 1-b.

Assembled in a standard 14-pin DIP, Fig. 2, the ULN2111 is designed to operate from a 12-volt dc source. With a frequency range of 5 kHz to 50 MHz, the device can furnish a typical voltage gain of 60 dB, and an output of 0.6 V. with a total distortion of less than 1% at a limiting threshold voltage of only 400  $\mu$ V rms. The unit's average current requirement is less than 20 mA. Input resistance is 5000 ohms shunted by 11 pF, while the detector's output resistance is 200 ohms. The internal de-emphasis resistance is 9000 ohms.

Suitable for use in both TV audio and FM broadcast applications, a practical limiter/detector circuit using the ULN2111 (IC1) is shown in Fig. 3. In operation, only a single coil, L1, is required for the phase-shift network, thus simplifying detector adjustment and alignment.

Referring to the schematic, T1 is the receiver's i.f. output transformer and C1 a dc blocking capacitor. Except for C8, all other fixed capacitors are low-voltage ceramic units, but C3 should be an NPO type. Audio coupling capacitor C8 may be a 30 to 50  $\mu$ F electrolytic. The resistors (R1 and R2) are standard 1/4- or 1/2-watt composition types.

If the circuit is to be used as a TV audio detector at 4.5 MHz, L1 should be a 7-14- $\mu$ H coil (Miller type No. 9052), R1 a 20,000-ohm resistor, and C4 a 3 pF capacitor. For 10.7-MHz operation in FM receivers, L1 should be 1.5-3  $\mu$ H (Miller type No. 9050), R1 3,100 ohms, and C4 rated at 4.7 pF. The output load,  $R_L$ , represents the input resistance of the following audio amplifier and, normally,

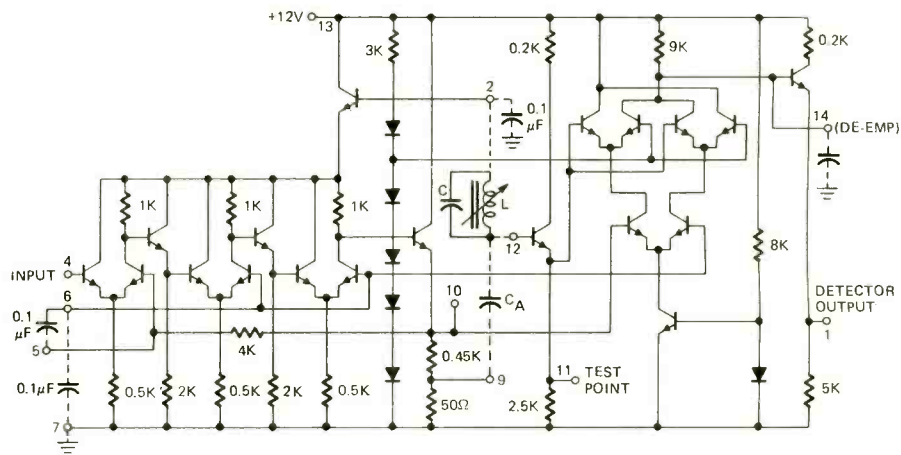
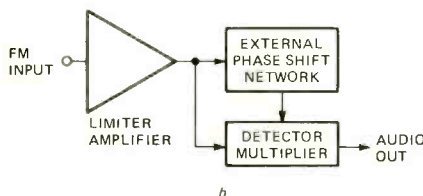

FIG. 1—INTERNAL SCHEMATIC (a) and block (b) diagram of Signetics' ULN2111 FM limiter/detector.



will be in excess of 200 ohms.

Although layout and lead dress are not overly critical, good rf wiring practice should be observed when duplicating the circuit. Signetics recommends that the decoupling capacitor leads at pins 5, 6 and 12 be kept as short as possible, with the connections to pin 4 as far removed as is practicable from the connections at pins 9, 10, and 12. The power supply connection at pin 13 should be bypassed to circuit ground with a 0.1  $\mu$ F ceramic capacitor, keeping the leads short. If the power source has a large internal impedance (such as a voltage dropping resistor), then an additional high-value electrolytic capacitor should be used at pin 13 for audio decoupling at the lowest audio demodulation frequency. Because of the circuit's

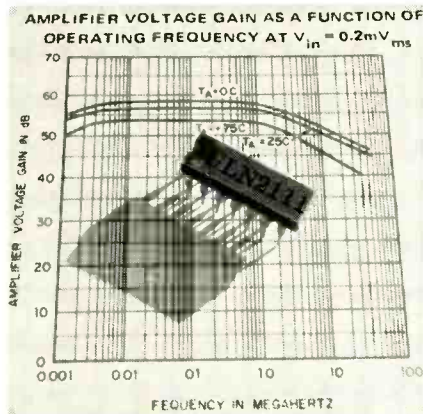

FIG. 2—THE ULN2111 is supplied in a standard 14-pin DIP.

high gain, L1 should be mounted at right angles with respect to input transformer T1 and spaced as far away as is practicable to avoid oscillation.

Circuit tuning is relatively simple. Apply an FM signal of suitable carrier frequency (4.5 or 10.7 MHz) through a dc decoupling network to pin 4 at approximately 5 mV rms. Adjust L1 for maximum audio output at pin 1 or maximum rf voltage at test point (T.P.) pin 11.

## Product/device news

Deep in the heart of the Lone Star State, the good guys at Texas Instruments (P.O. Box 5012, Dallas, Tex. 75222) have introduced a new series of one-ampere rectifier diodes, another of 750 mA. units, a family of high-voltage Darlington power transistors, and a new 10-digit binary-coded decimal arithmetic processor.

Designated types 1N4001 through 1N4006. TI's new 1-A diodes employ double-plug construction and hermetic sealing (see Fig. 4). With an operating ambient temperature range from -65°C to +175°C, the new diodes

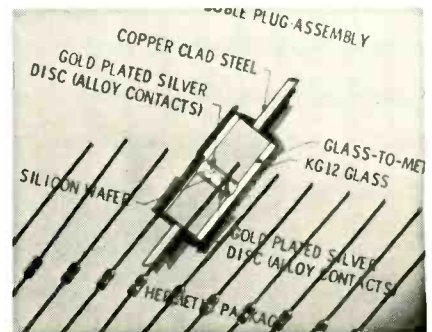

FIG. 4—TI'S NEW 1-AMP rectifier diodes.

This month we introduce more new semiconductors. The hottest of these are TV FM audio and dual zero-crossing detector IC's

by LOU GARNER  
SEMICONDUCTOR EDITOR

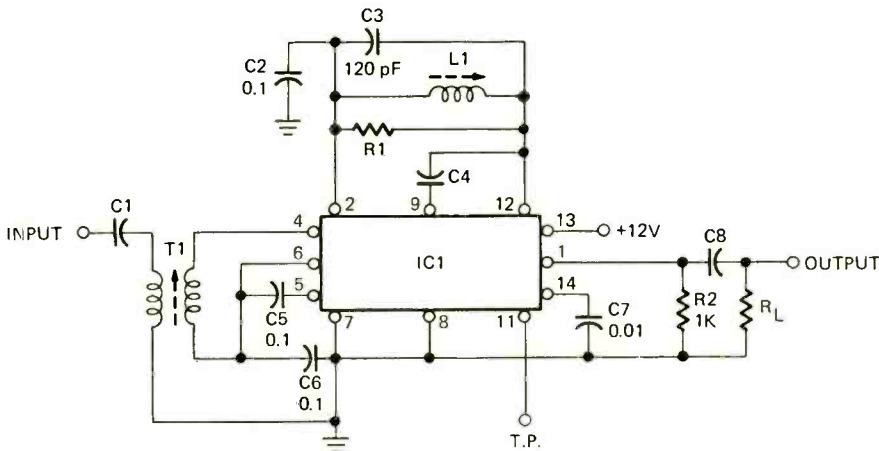

FIG. 3—PRACTICAL FM limiter-detector circuit . . . with suitable component values, the basic circuit may be used for both FM broadcast (10.7 MHz) and TV audio (4.5 MHz) applications.

carry PRV ratings from 50 V for the 1N4001 to 800 V for the 1N4006, while peak surge current capabilities are up to 30 A.

Kertron, Inc. (7516 Central Industrial Drive, Riviera Beach, Fla. 33404) has introduced a new low-cost commercial single diffused power transis-



FIG. 5—KERTRON'S NEW KD4044 high power transistor.

tor. Identified as the KD4044, the new unit is an npn device with a minimum  $BV_{CEO}$  rating of 40 volts and a minimum gain of 20. The new transistor, Fig. 5, is packaged in a hermetically sealed steel TO-3 case.

### Zero-zero

If you're a classic cinema buff, the expression *zero-zero* may evoke memories of an early aviation film with that title. The term referred to a common condition in the days before radar and ground controlled approach, when fog had closed in over an airport and created a condition of "ceiling zero, visibility zero." Our *zero-zero*, however, refers to another exciting and versatile monolithic integrated circuit announced by Signetics—

a dual zero-crossing detector.

A *zero-crossing detector*? Yes—a device (or circuit) that responds to an ac input signal when the voltage reaches zero during the transition from positive to negative polarity, and vice-versa. In addition to its intended primary application, the new device, identified as the model 363, also can be used as a high stability one-shot, a bi-directional one-shot, a frequency doubler, a stable low-frequency oscillator, a linear amplifier, and a frequency-to-voltage converter. Packaged in a 14-pin plastic DIP, the device nets for only \$2.15 each in unit quantities.

The internal block and schematic diagrams as well as pin connections for the 363 are in Fig. 6. Each of its two sections consists of 7 npn transis-

FIG. 6—BLOCK DIAGRAM (a) and internal schematic (b) diagrams for Signetics' type 363 zero-crossing detector.

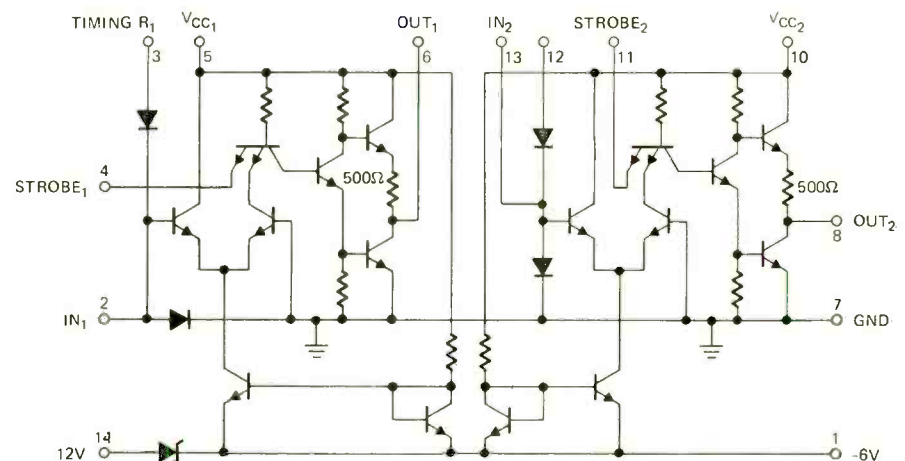

COMPONENT VALUES ARE TYPICAL  
PIN 3—NO CONNECTION

NOTE: PINS 5, 6, 8, AND 10 ARE TIED TO PIN 14 THROUGH ISOLATION DIODES.

tors, a dual-emitter npn transistor, 2 diodes, and 5 resistors, with a single Zener diode common to both. The device features temperature compensated differential amplifier inputs referenced to zero volts and TTL compatible outputs, and will convert low-level analog waveforms of  $\pm 30$  mV or more into digital signals.

In practice, two dc power sources are required for proper device operation. These may be +5 and -6 volts, referenced to ground, or +5 and -12 volts, again referenced to ground. In the -6 volts configuration, pins 1 and 14, Fig. 6-a, are tied together. When used in the -12 volts mode, however, pin 1 must be left open. Under no circumstances must the -6 and -12 volts sources be used simultaneously, for this will destroy the internal voltage-dropping Zener diode.

A basic circuit using half of a 363 as a zero-crossing detector is in Fig. 7-a. Power supply connections have been omitted for clarity, but these would be as indicated in Fig. 6. With the differential amplifier internally referenced to circuit ground, the circuit's

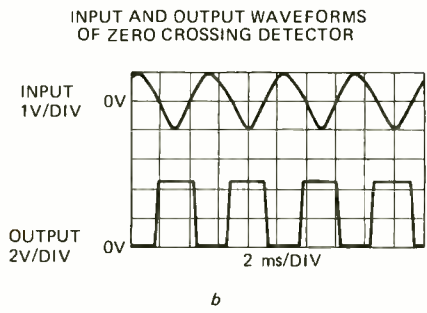
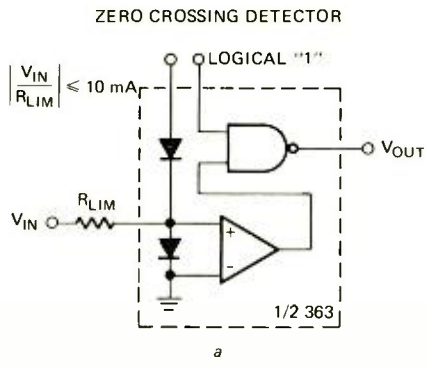

FIG. 7—CIRCUIT (a) and signal waveforms (b) of the basic zero-crossing detector.

output changes state each time the analog input signal passes through zero, converting the input signal waveform into a TTL compatible square wave, as shown in Fig. 7-b. In effect, the applied (input) signal has been sharply clipped to virtually eliminate distortion caused by amplitude fluctuations and noise, thus providing a "clean" digital signal for further processing.

A variation of the basic zero-crossing detector circuit is illustrated in Fig. 8-a. Here, both sections of the 363 are used to produce a complete output pulse each time the input signal waveform passes through zero voltage, rather than a simple change of state in the output signal. The net result is similar to the action of a frequency

FIG. 9—ADDITIONAL APPLICATIONS for the 363 zero-crossing detector: (a) low frequency oscillator, and (b) frequency-to-voltage converter.

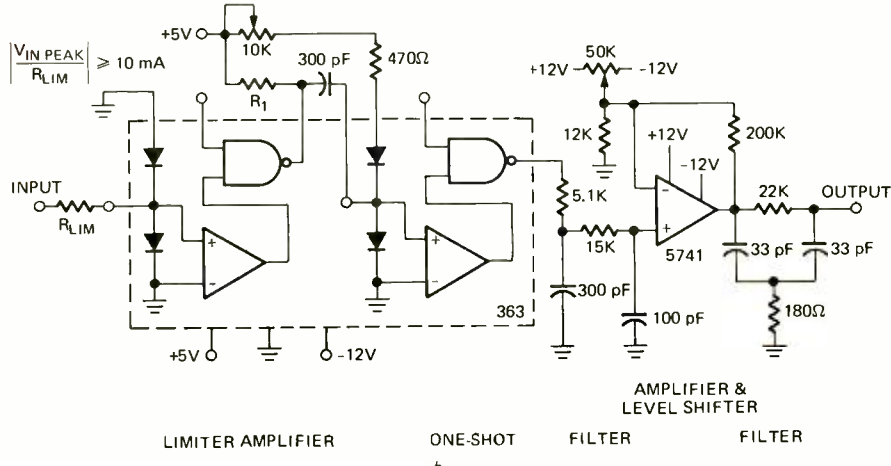

FIG. 9—ADDITIONAL APPLICATIONS for the 363 zero-crossing detector: (a) low frequency oscillator, and (b) frequency-to-voltage converter.

doubler, in that the output pulse signal is at twice the cyclic rate of the input signal, as demonstrated by the comparative signal waveforms given in Fig. 8-b.

The duration of each pulse is determined by the time required to pass through the threshold limits and depends on such factors as relative voltage levels, the choice of resistor values in the input voltage divider, and the inherent characteristics of the 363 itself. Typical values are 24,000 ohms for R1, 1,000 ohms for R2 and R3, and 30,000 ohms for R4. This circuit will not work with square-wave inputs having fast rise and fall times because there is not enough time between thresholds for the device to respond.

The 363's stable thresholds and high input impedances permit it to be used as a low-frequency oscillator. A suitable circuit using half of a 363 in conjunction with two type 380 NOR-gates is in Fig. 9-a. The operating frequency is determined by R1 and C1 and may be calculated by the approximate formula:

$$f_o \approx 1/2R1C1,$$

where R1 is in ohms, C1 is in farads, f<sub>o</sub> is in hertz, and R1 ≤ 100,000 ohms. Typically, with a 100,000-ohm resistor and a 1-μF capacitor, the output frequency is approximately 5 Hz.

Another interesting circuit application for the 363 is shown in Fig. 9-b—a frequency-to-voltage converter or pulse-counting discriminator, a type of FM detector. In operation, the input signal is applied through a current-limiting resistor to half of the 363, which serves as a limiter/amplifier. The output drives the second half of

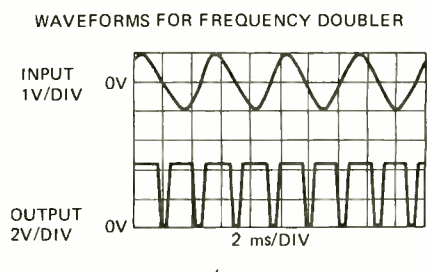
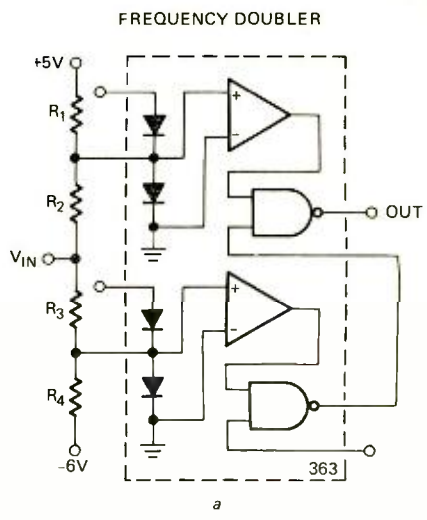

FIG. 8—CIRCUIT (a) and signal waveforms (b) illustrating the use of the 363 as a frequency doubler.

the 363, used as a one-shot to develop constant width output pulses at a rate determined by the input frequency.

A variable 10,000-ohm timing resistor permits the one-shot to be adjusted for the best linearity within the input frequency range. The original signal is now recovered by passing the constant width pulses through an RC filter network. Since the one-shot's filtered output is superimposed on an average positive dc level, the signal is applied to a type 5741 operational amplifier, which serves to shift the dc level and to amplify the signal even more. The dc level nulling is done by using a 50,000-ohm potentiometer to adjust the amplifier's negative (-) input bias. Finally, the amplifier's output, an amplified and demodulated signal restored to an average dc level of 0 volts, is filtered through a modified pi network to remove remaining carrier components.

When used as an FM discriminator with a carrier frequency of 1.5 MHz and a deviation of ±80 kHz, the circuit shown has a 3 dB bandwidth of 5 Hz to 35 kHz. The distortion at 1 kHz is less than 1%.

With additional potential applications as high stability and bi-directional one-shots as well as a linear amplifier, the 363 should be a welcome addition to the experimenter's and designer's stable of useful IC devices.

R-E



# Everything you wanted to know about video cassettes but didn't know who to ask



by ALFRED ZUCKERMAN\*

IN THE LAST FIVE YEARS, AS MANY AS TWENTY videoplay systems have been promised by as many manufacturers throughout the world. In 1970 it became apparent that no industrial or government group in the U.S. would commit itself to any single system.

Several manufacturers of video tape recorders in Japan evolved a joint program of development to produce a  $\frac{3}{4}$ " videocassette system for the world market. The introduction, in 1972, of machines using this format interchangeably by several manufacturers resulted in acceptance by U.S. government and large industrial users for training and educational applications. As a result of this universal acceptance the system has become a defacto standard. It is estimated that 50,000 of these machines have already been sold in the world market, half of them in the U.S.

At present there are five brands of  $\frac{3}{4}$ " cassette being distributed in the U.S.—Sony, Concord, Panasonic, JVC and Wollensak. Interchangeability standards are such that a cassette recorded on any brand machine can be played back on any other. All of these systems use a designation involving the letter "U" (which derives from the shape of the tape path) such as "U-Vision", etc. We shall refer to the format as  $\frac{3}{4}$ U.

The cassette is a precision molded package  $8\frac{3}{4}$ " wide by  $5\frac{1}{2}$ " deep by  $1\frac{1}{4}$ " thick and weighs about  $1\frac{1}{4}$  pounds for a full 60-minute tape load. The tape is  $\frac{3}{4}$ " wide and uses a high-density coating such as chromium dioxide or cobalt-doped ferric oxide to realize the full potential of the system. By using such tape it is possible to store 25% more information than with conventional gamma oxide tape. The two reels are coplanar and are accessible to the drive hubs as on the familiar audio cassette. A small plastic plug-button may be removed after recording to prevent accidental

erasure of the recorded material at a later date.

After the cassette is inserted, and the play (or record) mode is selected, a pin hooks under the tape and draws a U-shaped loop through a hinged door in the rear of the cassette (Fig. 5). By the action of the loading ring and its associated guides, this loop is drawn in a large circle over the erase head, around the rotary head drum, over the control/audio head and past the space between the capstan and pinch roller. When the appropriate position is reached by the tape the head drum starts rotating and shortly after that the pinch roller is automatically engaged and the tape motion at  $3\frac{3}{4}$  ips starts. This entire process takes approximately six seconds.

At any point in the program the stop button may be depressed. When this is done, the pinch roller disengages, the motion of the loading ring described above is reversed and the tape loop is returned to the cassette. This process takes about five seconds. The tape which is essentially opaque is spliced at both ends to a translucent leader. By using a light source and photo-sensing circuit we get automatic stop and rewind at the end of play as well as automatic stop in the FF (Fast Forward) and REW (Rewind) modes.

The technique used in recording the video signal is the now-familiar helical scan or slant-track method using two heads mounted diametrically opposite on a head drum assembly which rotates at 1800 rpm. Each half rotation of the head assembly corresponds to one field of the standard EIA defined frame. One complete rotation of the head assembly generates the two interlaced fields in  $1/30$ th second.

The information is placed on the tape in a carefully controlled pattern as shown in Fig. 1. The control track contains the information which permits the rotation speed and phase of the heads to be synchronized with the vertical synch signal. The audio tracks, which permit stereo recording are capable of providing frequency response up to 12kHz.

\*Vice President, Engineering, Concord Division  
Benjamin Electronic Sound Co., Farmingdale, N.Y.

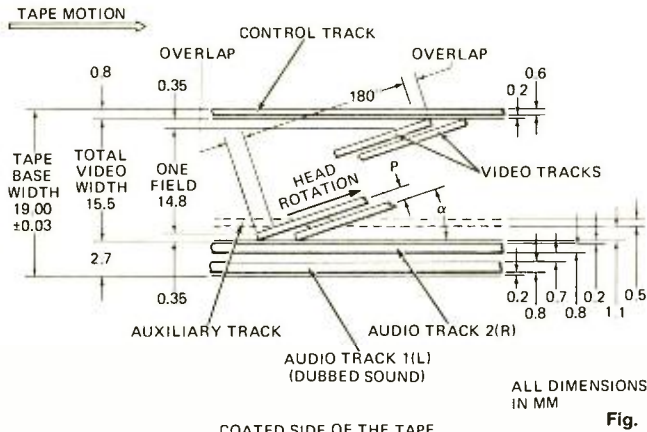

FIG. 1 (left)—TRACK PATTERN for 1/4-inch video cassette tape. Video track pitch ( $p$ ) is 0.1373 mm; tape stant ( $\alpha$ ) is 4°-54'-49.1\".

FIG. 2 (below)—SCANNING HEAD SPEED is controlled by comparing vertical sync pulse with output of head tachometer.

FIG. 3 (top right)—BLOCK DIAGRAM of the video playback processing circuit. Recovery of composite video is complex.

FIG. 4 (bottom right)—RECORDING CIRCUIT is represented by this block diagram. Color is converted to a 688-kHz subcarrier.

FIG. 5 (below)—CASSETTE LOADING MECHANISM before start of loading cycle. Pull-out arm takes tape to the head unit.

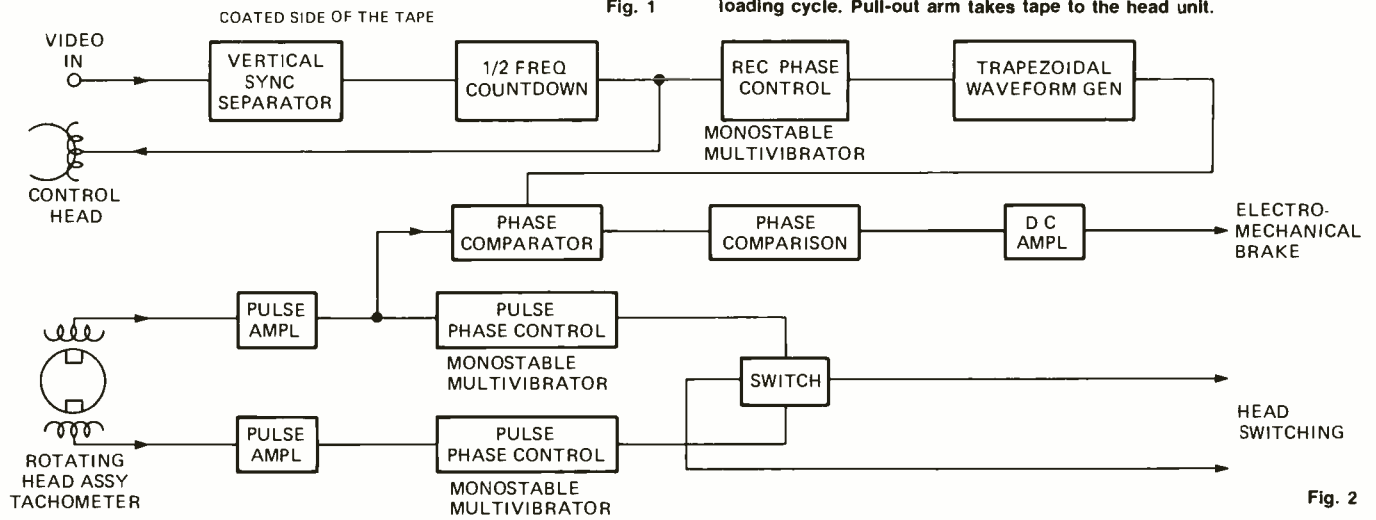

**Head speed control circuit**

Since the rotary head system is driven by a line synchronized motor, the servo function is performed by electro-magnetic braking of the rotary head shaft. During recording the vertical sync signal is stripped out and used as the reference for the control circuit (See Fig. 2). After counting down, squaring and then differentiating the sync signal, 30-Hz pulses are recorded on the control track. The same vertical sync information is compared with the 30-Hz head assembly tachometer signal in a sophisticated servo system which controls the velocity and head position of the rotary head system.

During playback a similar circuit compares the information on the control track with the tachometer output to ensure coincidence between the rotating heads and the recorded pattern.

The video cassette control circuits are not designed to permit interlocking the playback signal with other signals as in a television studio and as a result are simpler in structure and make for simplicity in operation. The signal processing for color and black and white is shown in the block diagrams, Fig. 3 and Fig. 4. A detailed description of all of the processes exceeds the scope of this article so that only those features that are of special interest will be dealt with.

To get the best signal in the recording and playback process it has been found that the B/W (black and white) and luminance information should be recorded on the tape in the form of a frequency modulated 3.8-MHz carrier. Extreme deviation for a white peak is to approximately 5.4 MHz and in the other extreme the sync-tip level results in the frequency to about 1.0 MHz.

The chrominance signal requires special attention to maintain color values. It is, therefore, extracted from the total video signal, converted to a 688-kHz subcarrier and directly recorded on the tape in the spectrum slot below

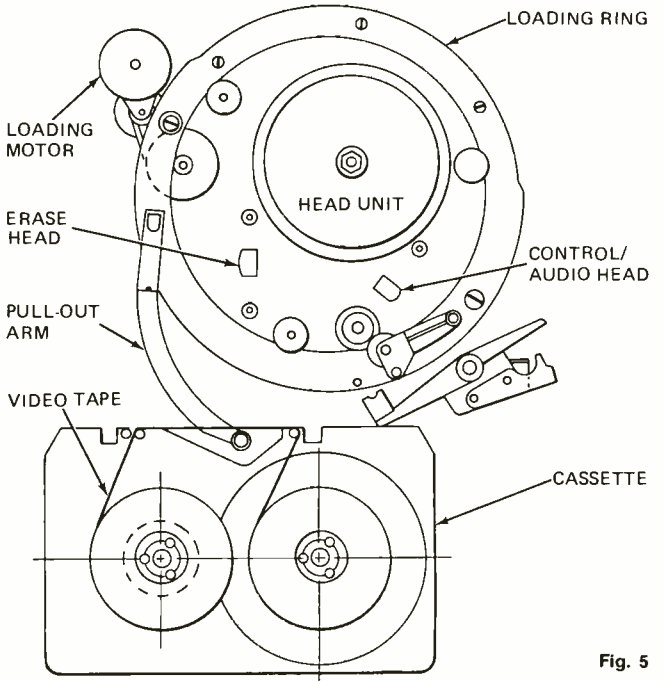

the frequency modulated luminance signal. To maintain a constant chroma level an automatic color compensation circuit uses the burst portion of the signal. Since the luminance signal level is controlled by its agc circuit, the ratio of luminance to chrominance signal is kept constant.

In the playback mode the video information recovered from the tape is amplified, limited, demodulated and further processed for optimum characteristics. The chrominance signal when recovered, however, contains what are called jitter components. These are small changes in fre-

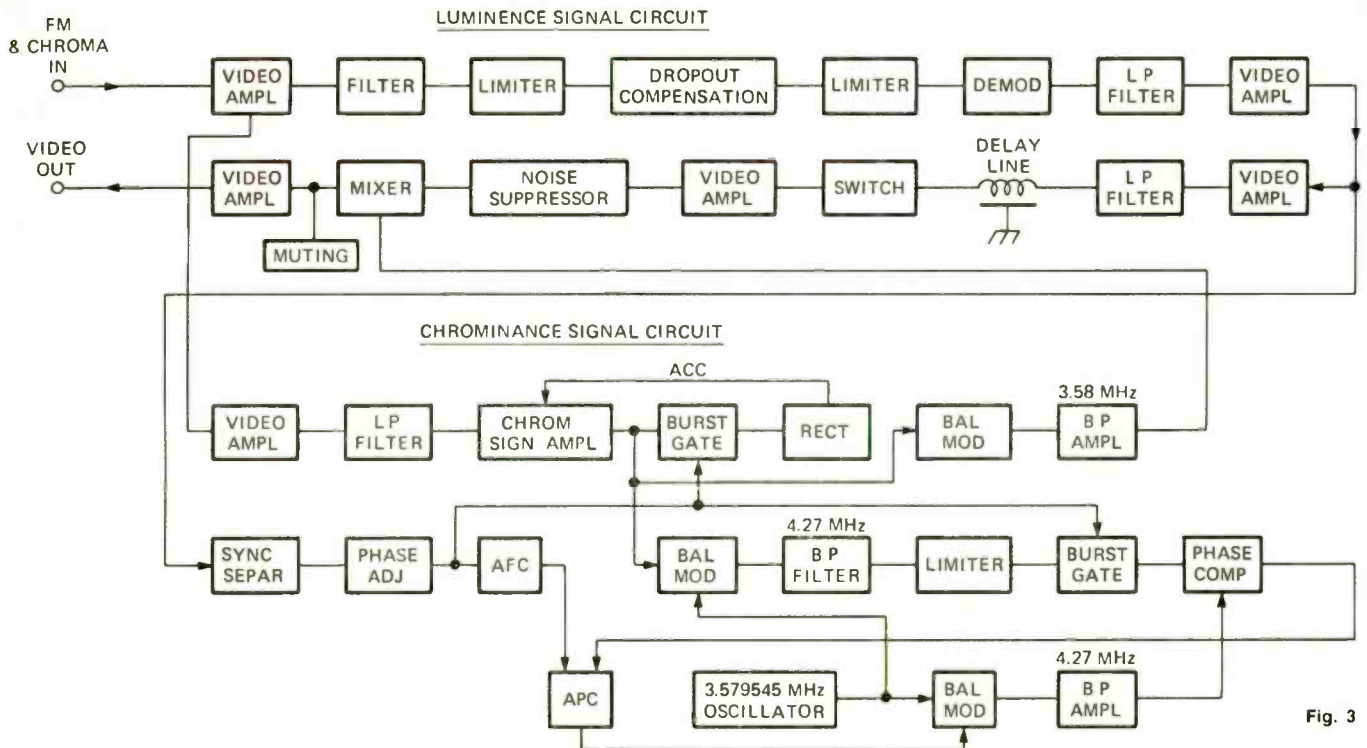

Fig. 3

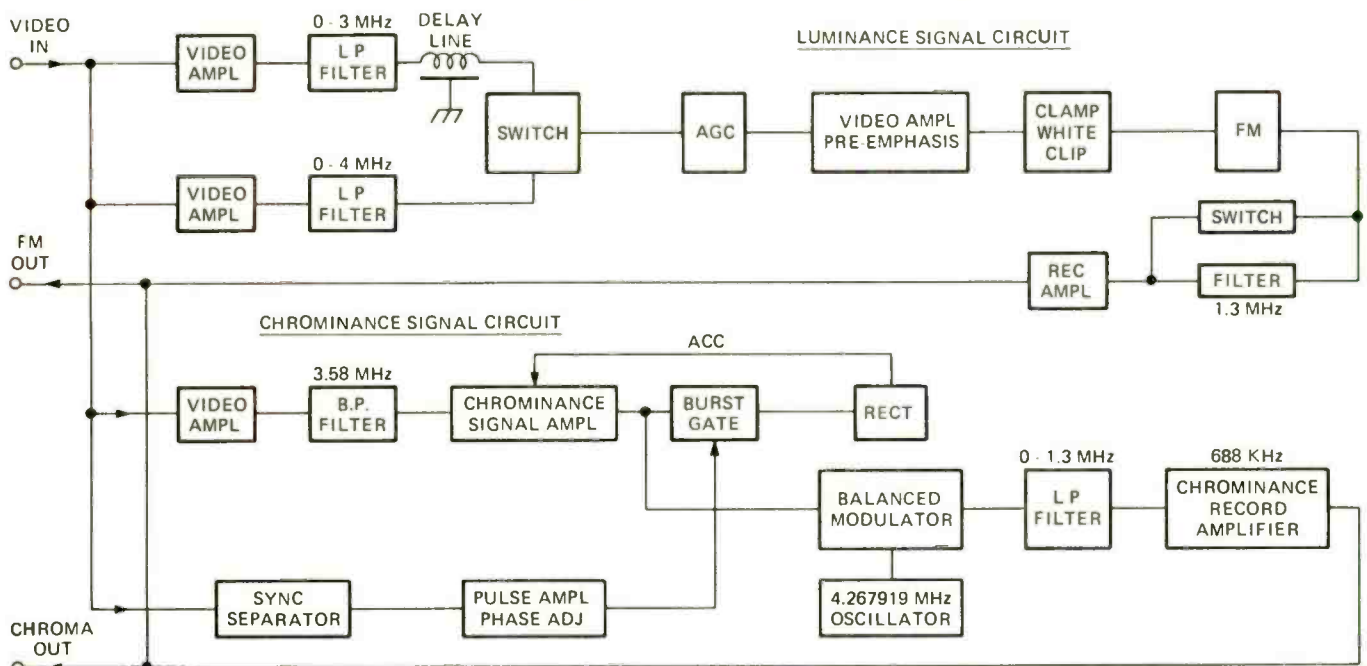

Fig. 4

quency due to minor defects in tape motion and are analogous to flutter and wow components in audio. Because the chroma information was directly recorded on the tape and not through the use of the FM carrier, the changes in tape motion result in frequency shifts which in turn cause a change in reproduced color.

To overcome this problem, two circuits are used. The automatic phase control circuit compensates for the higher frequency components of jitter while the automatic frequency control circuit compensates for the lower frequency components.

Now that the wide use of 3/4U is a fact it would be interesting to conjecture the reasons for its success and why it may continue to prevail over other systems being proposed. For the immediate industrial market which could afford the relatively high price tag the inducement was a technically sound system with simplicity of operation, both in record and playback. The bandwidth capabilities, the con-

trol of jitter and color reproduction and the ability to record for one hour were important factors. Other systems which utilized only a fraction of the fields, did not maintain color quality, did not have record capability or were not yet in production fell by the wayside.

Every manufacturer of the 3/4U system offers one or more modifications or accessories which enormously expand the usefulness of the device. Still Frame, Remote Control, Automatic Rewind at the End of Video Signal, Back Space and Pause are some of these useful functions.

What is the prospect for home use? There is no question but that the basic concept of the 3/4U anticipated use in the home. Every requirement for adaptation to a standard home TV set is available. An rf adapter is built in to provide Channel 5 or 6 output. Recorders are available with built-in uhf/vhf front ends. When volume production permits prices to be pegged lower, the 3/4U is a natural for the home.

R-E

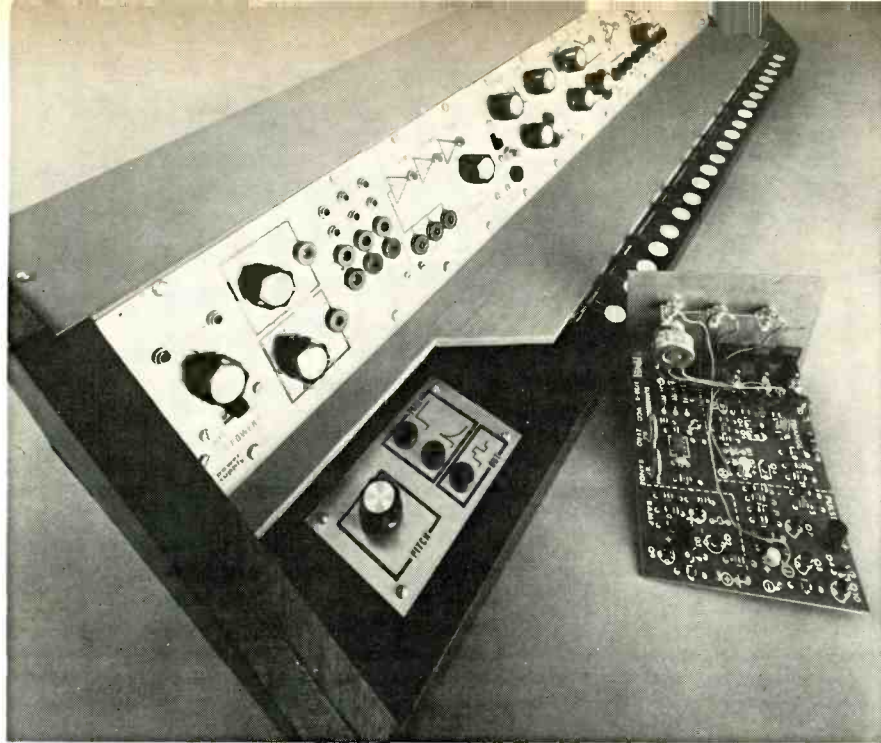

**BUILD**

# A MODULA

Part II: T  
this ur

tempered musical scale. Adjustable wire contacts make the connections between the resistance element and the key springs.

There are two contacts associated with the controller as indicated by the lines above and below  $R_k$  in Fig. 7. The upper line corresponds to the voltage pick-off spring that is the first to be contacted by the key spring when a key is pressed. The second line represents the key-down detector strip which contacts the key spring/pick-off spring combination when

THIS ISSUE WE WILL SHOW YOU HOW THE electronic controller circuit of the synthesizer works and how to build it. The project is relatively simple and results in an additional module for your instrument.

### Controller/case

Since the primary pitch sources in synthesizers are voltage controlled, a wide variety of controllers ranging from automatic sequencers to joy sticks are possible.

The controller that we will describe is a keyboard arrangement that is designed to be built from materials commonly available in hobby shops and variety stores. If you are able to locate a standard organ keyboard it can probably be adapted to the electronics package but since keyboards vary from one manufacturer to another it is impossible to give specific details that will apply to all keyboards.

### The controller circuit

Reduced to basics the controller is nothing more than a switch controllable voltage divider but it starts to get a little more complicated as "housekeeping" functions are added. In addition to the voltage divider the circuit includes a constant-current source, trigger circuit and sample/hold circuitry.

The constant-current source is a standard design built around Q1 and using the voltage drop across the series combination of D1 and D2 as a reference. The output of the current source is regulated by changing the dc feedback with emitter resistor R20. The current source feeds the voltage divider shown in Fig. 7 as  $R_k$ .

In practice the resistance is a strip of conductive vinyl having a resistivity of 377 ohms/square. One edge of the vinyl strip is cut along a curve causing the total resistance to any point on the strip—and consequently the voltage at that point—to be exponentially related to the distance from that point to the low voltage end of the strip. The need for the exponential voltage will be fully covered in another article, but for now it will suffice to say that it relates to the exponential nature of the equally

FIG. 7—(far right) COMPLETE CIRCUIT of the controller electronics. Two IC's and six transistors are used. FIG. 8—(below) PARTS PLACEMENT on the circuit board. FIG. 9—(bottom) FOIL PATTERN of the controller circuit board.

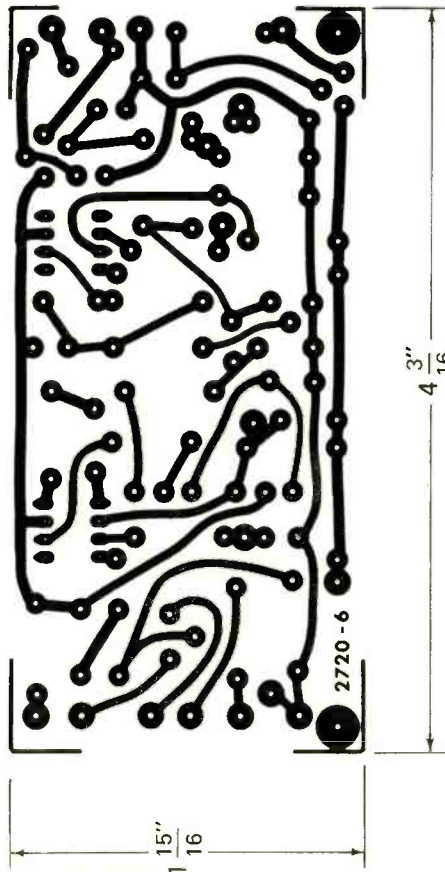
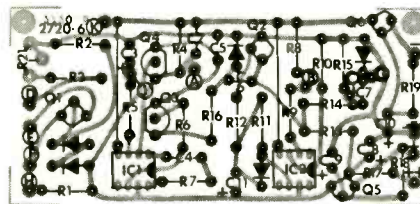

### PARTS LIST (Controller Electronics)

- C1, C7—.01- $\mu$ F disc
- C2—.001- $\mu$ F disc
- C3, C11—2.2- $\mu$ F 10V electrolytic
- C4—100-pF disc
- C5, C6—.1- $\mu$ F mylar
- C8, C9, C10—33- $\mu$ F 10V electrolytic
- D1 thru D5—1N914
- IC1, IC2—748 op-amp
- Q1, Q6—2N5139
- Q2, Q5—2N5129
- Q3, Q4—MPF-102
- All resistors— $\frac{1}{2}$ W 10%
- R1—470 ohms
- R2—10,000 ohms
- R3, R17, R18, R19—680 ohms
- R4—15,000 ohms
- R5—100,000 ohms
- R6—68,000 ohms
- R7—82,000 ohms
- R8—1 megohm
- R9, R16, R22—3.9 megohms
- R10—150,000 ohms
- R11—22,000 ohms
- R12—4700 ohms
- R13—20,000 ohms, 5%
- R14, R15—33,000 ohms
- R20—linear taper potentiometer, 1000 ohms
- R21—pc mounting trimmer pot, 1000 ohms
- MISC: Case, circuit board, hardware, control panel, wire, solder, etc.

### KIT SUMMARY

The following items are available from, PAIA Electronics, Inc., P.O. Box 14359, Okla. City, OK 73114

No. 2720—Kit of all parts for duplicating the complete synthesizer. Includes all parts, panels, circuit boards and detailed instructions. \$139.00 plus postage for 18 lbs and insurance

No. 2720-2—VCO kit including circuit board. \$24.95 ppd.

No. 2720-2pc—VCO circuit board only. \$4.00 ppd

No. 2720-6—Controller/case kit. \$37.00 + 18 lbs. postage

No. 2720-6pc—Sample/Hold circuit board. \$3.50 ppd.

No. 2720-7—Power Supply kit. \$22.00 + 2 lbs. postage

No. 2720-7pc—Power Supply circuit board. \$4.00 ppd.

A controller kit featuring a professional 3 octave organ keyboard is also available. Details available on request.

\* President, PAIA Electronics

# ELECTRONIC MUSIC SYNTHESIZER

controller electronics is the primary pitch source for  
It is a switch controllable voltage divider

by JOHN S. SIMONTON, JR.\*

the key is fully down to play a note.

When a key is depressed, C3 begins to charge or discharge. This capacitor is simply an integrating capacitor to bypass noise from dirty or corroded contacts. Almost simultaneously, the key-down detector strip is raised from near negative supply (where it is held by R22) to whatever voltage is on the key spring being pressed. Since this new voltage is always greater than the -1-volt reference at the "+" input of op-amp

comparator IC2., the output of the comparator switches from its normal high state to a voltage near negative supply. After a time determined by the discharge rate of C11 (20 ms typically) Q2 switches off causing the voltage at its collector to go from near ground up to "+ +" supply. This voltage charges C6 through D4 and turns on Q3.

The sample-and-hold circuit can be further broken down into comparator IC1,

high input impedance FET source follower Q4, and switch Q3. The comparator is constantly comparing the input from the voltage pick-off spring to the output which appears across the load resistor of the source follower R4. The state of this comparator has no effect on holding capacitor C5 (and consequently the source follower for which this capacitor is an input) until Q3 is turned on. With Q3 on, the comparator acts to make the voltages at its "+" and "-" inputs identical and when the voltages are identical the circuit is balanced. Since Q4 is effectively in the feed-back loop of IC1, a FET with practically any specs can be used.

When the key is released, comparator IC2 switches and immediately turns Q2 on (C11 discharges through D3 and the low output impedance of IC2 almost instantly). When Q2 switches it "pushes" the end of C6 that is connected to the anode of D4 down to about -15 volts, the voltage C6 charged to when Q2's collector was high, causing D4 to reverse bias and thereby removing all discharge paths other than stray leakage. This large negative voltage allows for considerable variations in the parameters of Q3 so that an inexpensive device may be used here.

With Q3 off, holding capacitor C5 is isolated from any discharge paths but still serves as the source follower input so that the output voltage does not change.

The voltage step trigger output is derived from Q2 through voltage divider R14 and R15 and the pulse trigger output is formed by differentiating the step through C7. Diode D5 clamps the negative voltage spikes to ground. Q5 and Q6 serve as capacitance multipliers for the filter capacitors C9 and C10.

## Put it together

The assembly of the electronic portion of the controller is pretty straightforward but because of the high gain characteristics of the two operational amplifiers you will be ahead using an etched circuit board. The etching guide is in Fig. 9.

Be just as careful with this circuit as you were during VCO assembly. Note that not all of the parts associated with the sample and hold circuit are mounted on the circuit board. Resistor R22 and ceramic disc capacitor C1 are mounted at the end of the coax that connects the sample/hold input to the voltage pick-off wire on the keyboard. Also note the two wire jumpers on the circuit board.

Next month we will show how to build the keyboard for the synthesizer and how the modules connect into the case and main-frame. You will then have a basic synthesizer and will be able to start playing it. R-E

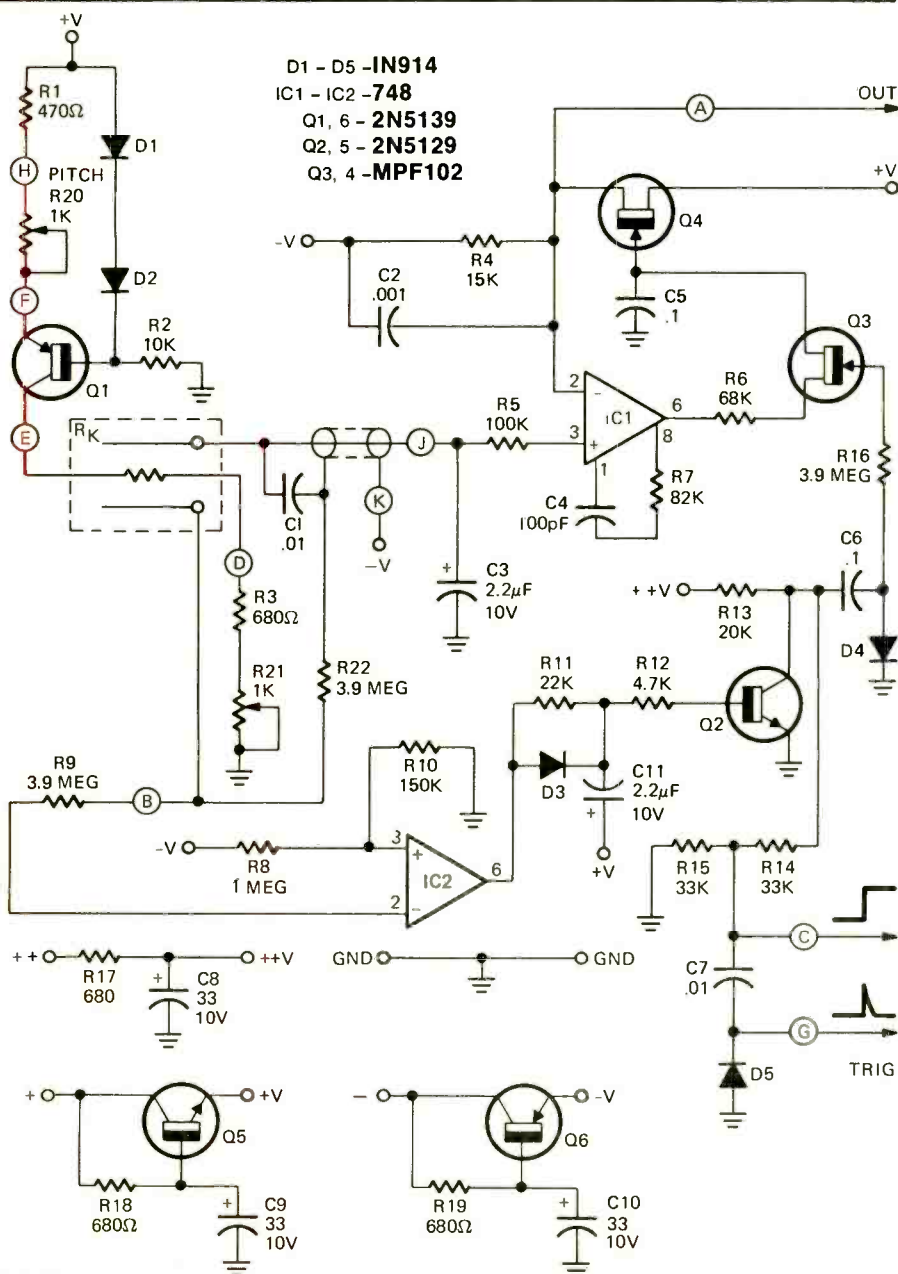

# STEP-BY-STEP TV TROUBLE-SHOOTER'S GUIDE

WHEN SERVICING A MODULAR TV, THE main consideration is, what is the fastest and least expensive path to the completed repair? Very often the actual defective part is never located because it is less expensive to simply plug in a new module than troubleshoot down to the end of the puzzle and come up with the bad part.

There are some components on the modules that should be checked before changing the entire device. For instance, in the G-E i.f. module we are going to discuss, the IC and transistors should get a quick check before changing the module.

Modular TV's still require a technician, even though he has a less challenging job. Before you just shove in a new module there are troubleshooting procedures. Let's look at a G-E MA

25 chassis and check the i.f. module.

## How it works

The i.f. module is enclosed in a metal shield, to preserve the i.f. alignment. Since the modules must be interchangeable, unlike ordinary i.f. strips that have to be realigned at the slightest provocation, the i.f. input circuit is unusual. Instead of having a pair of double-tuned circuits coupling the tuner output to the i.f. input, the tuner is a single broadly tuned circuit that has little or no effect on the i.f. response.

There are three coaxial cable phono-type plugs and two cable plugs. There are two screws, one at each side

of the module, that secure it in place.

The link coupler is conventional and is centered around the tuning of L201. Attached to the link are adjacent-channel traps L202 (adjacent video) and L203 (adjacent audio). The i.f. signal is injected into IC201. This integrated circuit contains the first and second stages and the agc keyer and amplifier. The third and fourth i.f.'s are ordinary npn transistors.

An audio i.f. trap (L107) tuned at 41.25 MHz is in the collector circuit of the third i.f. It not only attenuates the audio i.f. right there in the 3rd i.f. so it can't get into the video, it also provides a tap for 41.25-MHz amplifier Q208, called the auxiliary amplifier.

Some of the i.f. signal is picked off at the coupling between the third and fourth i.f.'s and fed to IC202, the

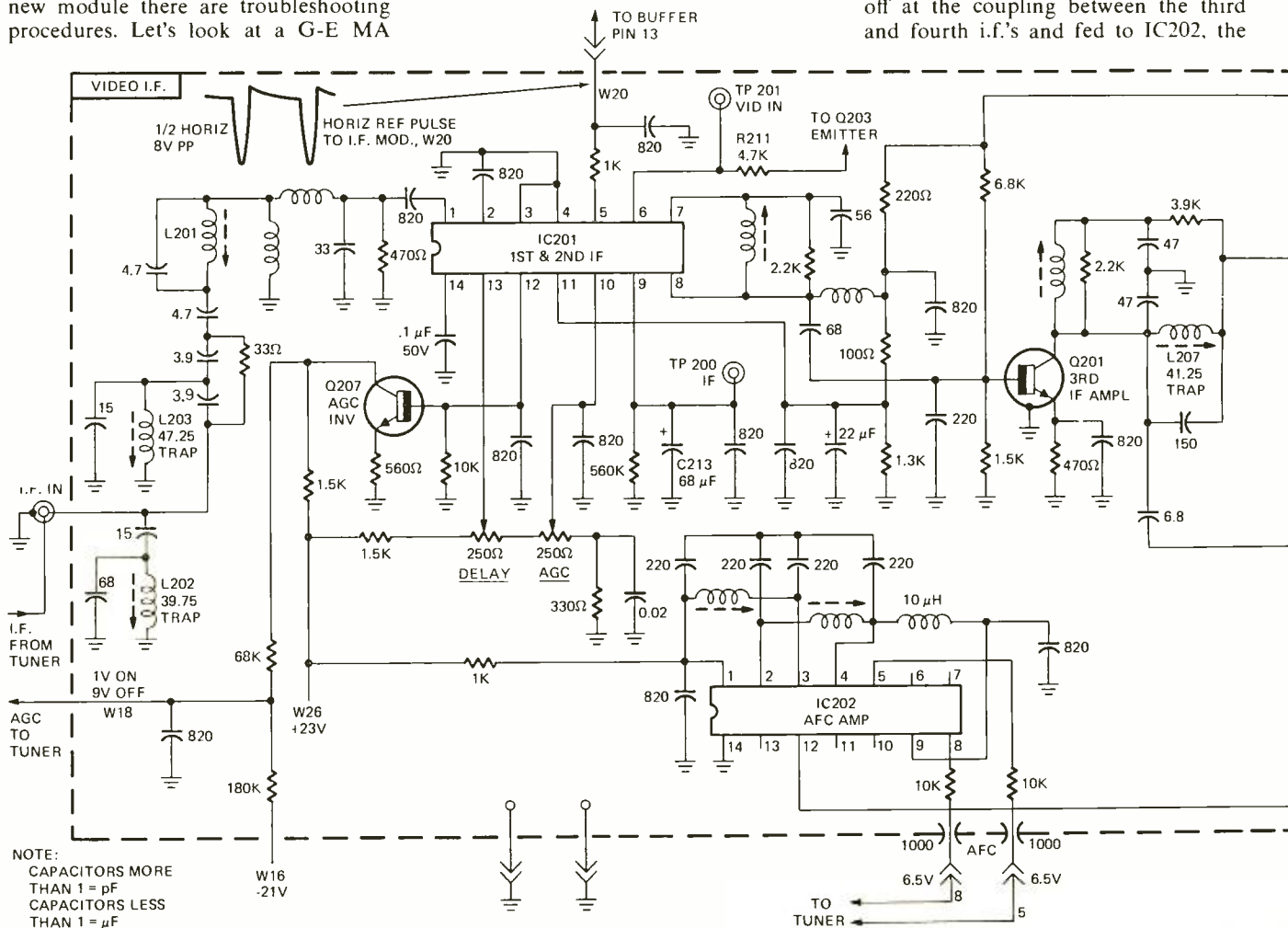

Before replacing a defective module in a TV set, try to localize the defective component. It may be something as simple as a bad IC, capacitor or resistor

by ART MARGOLIS

afc amplifier supplying the tuner.

The collector of the 4th i.f. feeds the video detector through a double-tuned circuit. The detector has a negative output that goes to the base of the 1st video amplifier. R229 is the detector load resistor.

The second video amplifier Q204 is an emitter follower. The 4.5-MHz trap is L215 and its associated components. The SOUND REJECT pot is factory preset. The emitter follower matches the video output into the next module called "video low level".

In addition to routine i.f. duty the module also performs work in the agc, afc and audio i.f. However, since we are only discussing the **RASTER ONLY** symptom this month and afc and audio are not involved we'll only cover the agc, along with the i.f.

Agc—Integrated circuit IC201 contains all of the agc circuitry except the final agc delay which is centered around Q207, the agc inverter.

Terminals 5, 6, 9 and 10 lead into the agc keyer stage. The flyback pulse from the horizontal buffer module goes into terminal 5. The video signal enters 6 and the i.f. agc control is attached to 10. The agc storage capacitor C213 hooks into 9.

Conduction in the agc inverter is controlled by the dc voltage fed to its base from terminal 12. Q207 amplifies and inverts the voltage changes. A small positive voltage change at the base causes a large negative voltage change at the collector. This varies the agc input to the tuner rf stage.

A series voltage divider between -21 and +23 volts sets up the col-

lector voltage for this stage.

In between pins 5, 6, 9 and 10 and pin 12 on the IC201 lies the agc keyer, agc amplifier and initial agc delay stages, all in microminiature form completely inaccessible to a test probe. The technician, from a practical standpoint, can forget about these stages as separate entities and think of them in a block diagram manner. When agc trouble strikes, the IC replacement is first automatic step.

When the symptom **rastrer only** occurs, the prime suspects are the tuner, i.f. strip and agc circuits.

The modular approach, even though quite easy still requires a voltmeter and scope. Perhaps you could get by with a P-P voltmeter scale but the scope is the most accurate.

Isolate the trouble before disconnecting and unscrewing everything. This brings up a precautionary measure. Do not pull or re-attach any plugs unless the TV is **OFF**. Otherwise a static or filter charge could blow a transistor or IC, compounding the problem.

The approach is to disconnect the coax cable that goes from the tuner to the i.f. module. Then turn on the TV and analyse the raster and audio. Is there any snow or static?

If there is, the tuner area has the trouble. Test the coax cable. It could be shorted or open. If it is OK then test the tuner inputs. When there is no B+ then the power supply becomes suspect. If there is no rf agc, the i.f. module rf agc area is indicated. When both B+ and rf agc check out correctly, then the tuner needs service.

When the symptoms remain the same, and with the cable disconnected and there is no snow or static, the i.f. module area is the seat of the trouble.

First step there is to quick check. Try a new horizontal buffer module. It could be the agc keyer pulse is not arriving and the buffer module could be at fault. If that doesn't cure, then try a new IC201. If that doesn't fix the trouble, reach for the voltmeter again.

When they do not have the test replacement parts, like the buffer module and IC201 on hand, a lot of technicians will skip those steps and

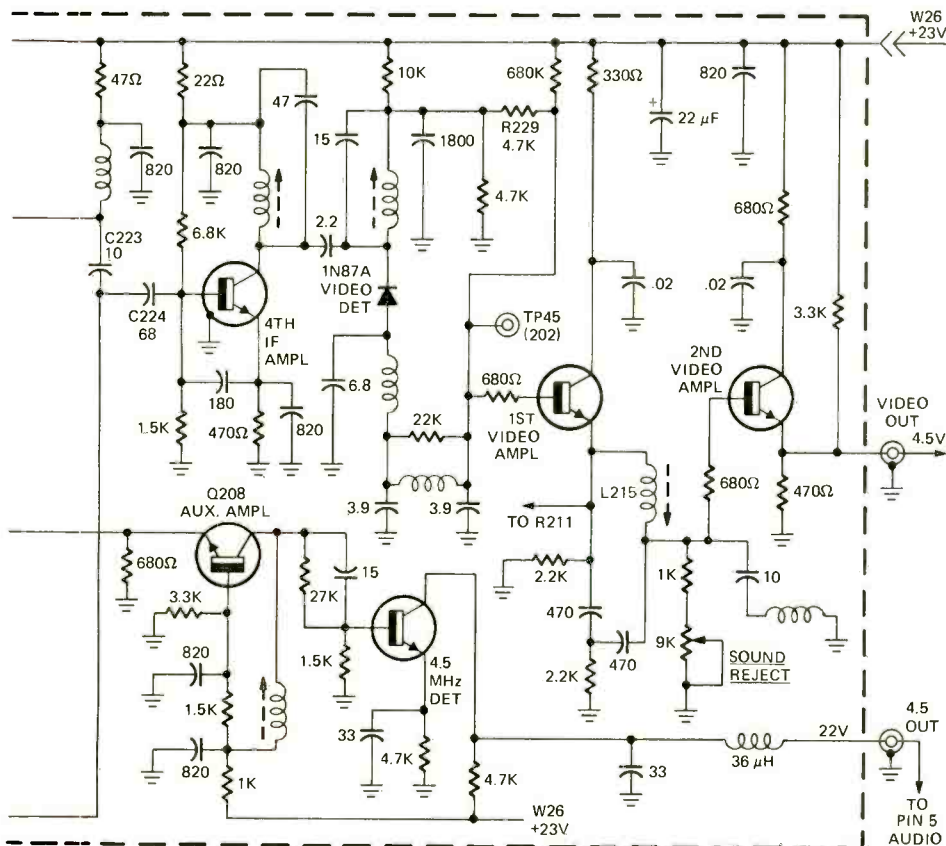

**SCHEMATIC DIAGRAM** of the i.f. module in the G-E type MA color television chassis. Two integrated circuits greatly reduce the number of components that can fail and cause trouble. Terms such as auxiliary amplifier and 4.5-MHz detector are new but their functions are not.

dig into the circuits. This is foolish because for the large percentage of times, the trouble is not in the circuits, but is in these modules or IC's. It's better to wait a day or two till the part is obtained than dig into good circuits.

Once the modules, IC's and other easily checked parts have been eliminated as trouble sources, read the B+ input at W26 and B- at W16. If either is missing then the power supply is indicated.

If voltages are present and cor-

rect, it's now scope time. Look at the agc keyer pulse at W20. It should be about 8 volts P-P.

If the pulse is missing the buffer module and connecting wires are suspect. Should the pulse be present and correct then test the 3rd i.f. transistor Q201 and the agc inverter transistor.

When the transistors are good, the time has come. It is now economically sound to replace the i.f. module.

Turn off the TV, unplug and unscrew the old unit and reinstall the new.

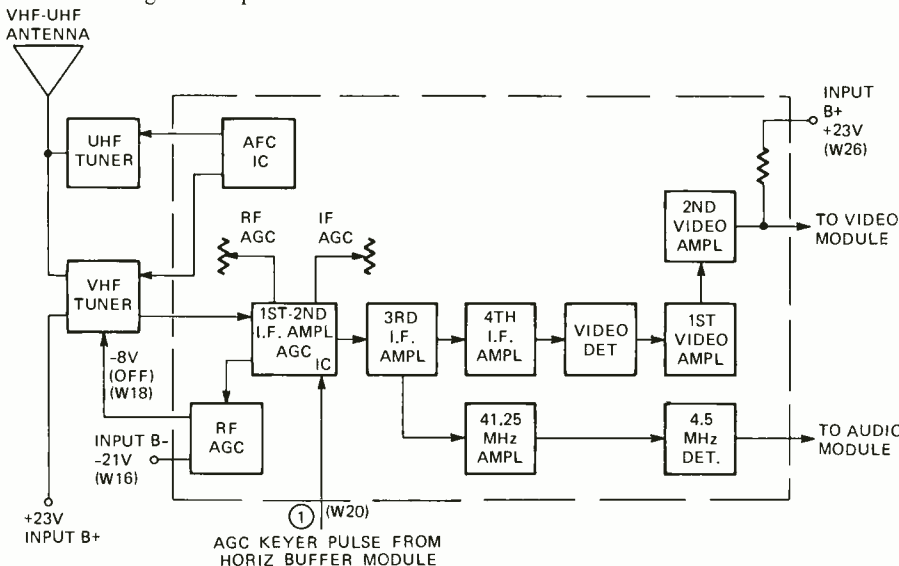

**BLOCK DIAGRAM** shows the circuit breakdown and function of the various elements making up the i.f. module in the General Electric MA TV chassis. This simplifies troubleshooting.

## Module repair

Since there are so many discrete components and the i.f. module is worth money, if you have a little time, you could repair the module with conventional printed board techniques.

If it's a "raster-only" symptom then the 4th i.f., video detector, 1st and 2nd video amplifiers and both audio circuits are eliminated. If the video circuits are defective you'll still have sound since the audio is picked off in the 3rd i.f. The afc IC of course is hardly involved.

That leaves the i.f. link circuit, IC201, Q201 and Q207 circuits. It might be worthwhile to trace the circuit from W16 to W26 through the series divider network. Also trace electron flow from the collector of Q201 to W26. Lastly, check the emitter resistors of Q207 and Q201. It's just possible you'll lock-in on a bad component.

If not, from an economic standpoint, the old i.f. module is junk and should be discarded (or if in warranty, credited). The only time it has to be repaired is when the TV is in a remote area and the replacement module is absolutely not available. **R-E**

## R-E's substitution guide for replacement transistors

### Part IV

compiled by ROBERT & ELIZABETH SCOTT

R-E's Transistor Substitution Guide is a compilation of material abstracted from the substitution guides of eight leading semiconductor manufacturers and distributors. These are:

**ARCH**—Indicates the Archer brand of semiconductors sold only by Radio Shack and Allied Radio stores. Allied Radio Shack, 2725 W. 7th St., Ft. Worth, Texas 76107

**G-E**—General Electric Co., Tube Product Div., Owensboro, Ky. 42301

**ICC**—International Components, Div. of IESC, 10 Daniel Street, Farmingdale, N.Y. 11735

**IR**—International Rectifier, Semiconductor Div., 233 Kansas St., El Segundo, Calif. 90245

**MAL**—Mallory Distributor Products Co., 101 S. Parker, Indianapolis, Ind. 46201

**MOT**—Motorola Semiconductors, Box 2963, Phoenix, Ariz. 85036

**RCA**—RCA Electronic Components, Harrison, N.J. 07029

**SPR**—Sprague Products Co., 65 Marshall St., North Adams, Mass. 01247

**SYL**—Sylvania Electric Corp., 100 1st Ave., Waltham, Mass. 02154

Radio-Electronics has done its utmost to insure that the listings in this directory are as accurate and reliable as possible; however, no responsibility is assumed by Radio-Electronics for its use. We have used the latest manufacturers material available to us and have asked each manufacturer covered in the listing to check its accuracy. Where we have been supplied with corrections, we have updated the listing to include them. The first part of this Guide appeared in March 1973.

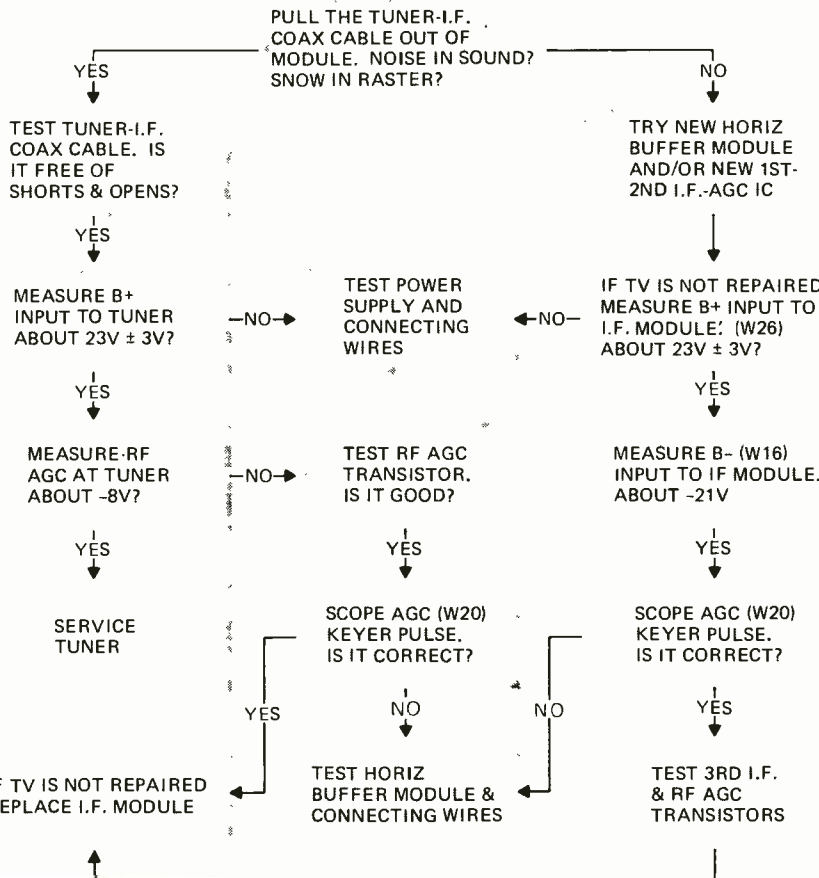

**QUICK-CHECK TROUBLESHOOTING CHART** leads you step-by-step through detailed servicing procedures. You perform the various tests almost as fast as you can locate the test points.





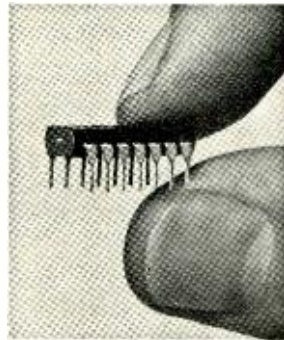
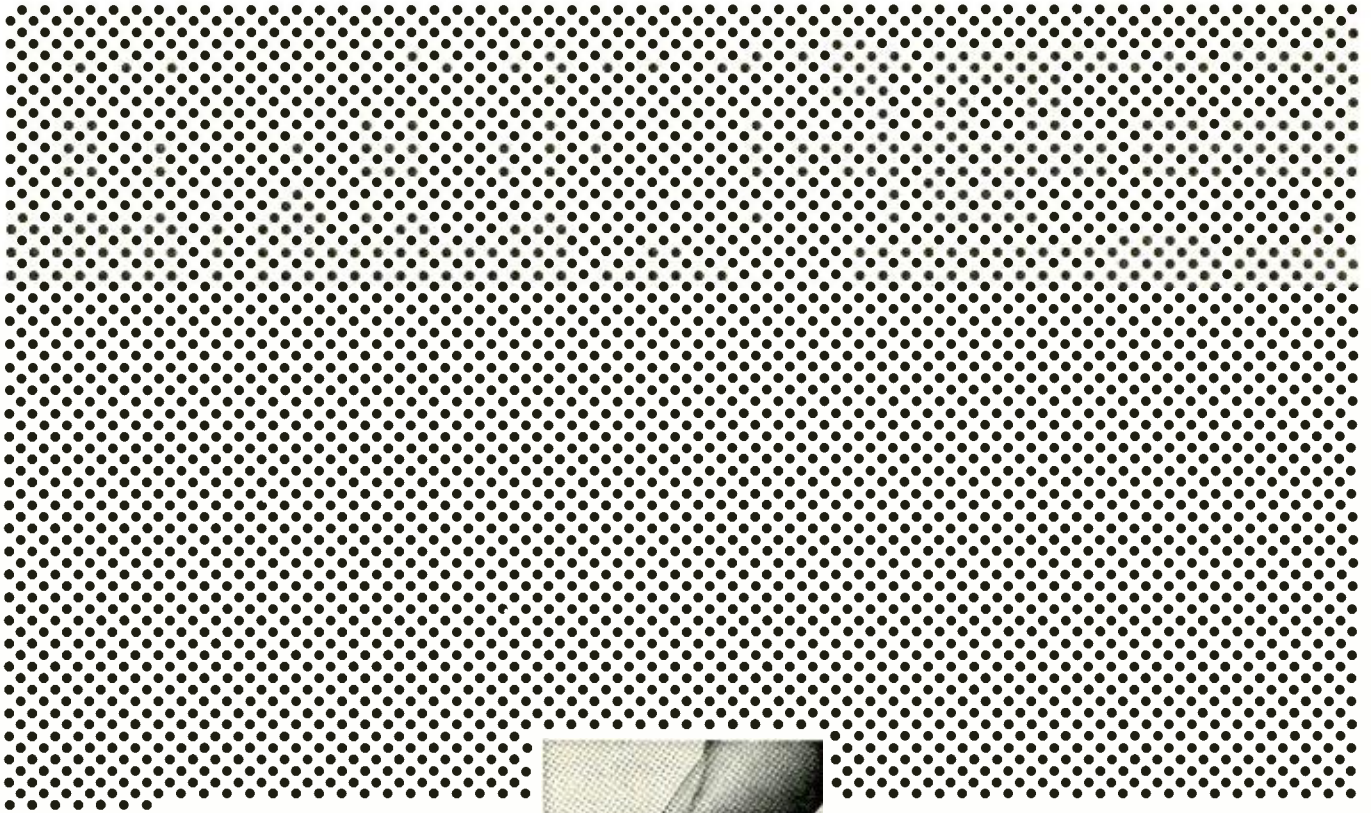

*4,000 functions in a single LSI circuit. The functions of four thousand separate transistors, represented by the dots above, can now be performed by the LSI circuit shown in the photo.*

# LSI...will it make or break your job future?

The development of LSI (large scale integration) technology in the 1970's is the dawn of the newest revolution in Electronics. It means that many of today's job skills soon will be obsolete. But at the same time, it opens the door to thousands of exciting new job opportunities for technicians solidly grounded in electronics fundamentals. Read here what you need to know to cash in on the Science of the Seventies and how you can learn it right at home.

LSI circuits, some no bigger than a bumblebee, are bringing about a fantastic new Industrial Revolution. Already these miracles of micro-circuit technology are a part of exotic equipment that saves lives, works complicated mathematical formulas in an instant, or tells time within a tolerance of two seconds per year.

LSI's may also put you into a whole new and more rewarding career . . . or put you out of a job!

In the fall of 1972, BUSINESS WEEK reported, "Be-

cause of its fast pace of innovation, the U. S. semiconductor industry leads the world. In the LSI market, U. S. domination is even more pronounced."

A single LSI circuit now can perform the function of more than 4,000 components and scientists predict that the use of electron beams to trace the circuit patterns will soon make it possible to put 10,000 transistors and similar devices on a silicon chip a few millimeters square.

## Miniature Miracles of Today and Tomorrow

Already, as a result, a two-way radio can now be fitted inside a signet ring. A complete hearing aid can be worn entirely inside the ear. There is a new computer/calculator that weighs only nine ounces, fits easily into a shirt pocket, yet in a split second performs logarithmic, trigonometric and mathematical functions with a single keystroke and 10-digit accuracy. And new, extremely accurate watches consisting only of a quartz crystal, LSI circuits and a solid-state time display take only minutes to assemble.

And this is only the beginning.

Soon kitchen computers may keep the housewife's

refrigerator stocked, her menus planned, and her calories counted. Her vacuum cleaner may creep out at night and vacuum the floor all by itself.

Money may become obsolete. Instead you will simply carry an electronic charge account card. Your employer will credit your account after each week's work and merchants will charge each of your purchases against it.

When your telephone rings and nobody's home, your call will automatically be switched to the phone where you can be reached.

Doctors will be able to examine you internally by watching a TV screen while a pill-size camera passes through your digestive tract.

### New Opportunities for Trained Men

What does all this mean to someone working in Electronics who never went beyond high school? It could mean the opportunity of a lifetime — if you take advantage of it.

It's true that the "LSI" may make a lot of manual skills no longer necessary.

But at the same time the booming sale of articles and equipment using integrated circuitry has created a tremendous demand for trained electronics personnel to help design, manufacture, test, operate and service all these marvels.

There simply won't be enough college-trained engineers to go around. So men with high school educations who have mastered the fundamentals of electronics theory may soon fill really interesting, high-pay jobs as engineering aides, technicians and service specialists.

### How To Get the Training You Need

You can get the up-to-date training in electronics fundamentals you need and do it at home in your spare time without giving up your present job or income. Cleveland Institute of Electronics courses are specially designed for home study and feature AUTO-PROGRAMMED® Lessons. Even if you have no experience in Electronics or had trouble studying before, CIE courses help you advance faster and easier than you would have believed possible. You learn at your own pace.

Unlike a classroom situation where you have just one instructor throughout the course, at CIE you get help from a number of instructors. Each is selected on the basis of his specialized knowledge of a particular area of Electronics. In this way, you benefit from the combined knowledge of our entire staff.

### Money-Back FCC License Warranty

A Government FCC License is certification of your knowledge of Electronics. Some jobs, especially in broadcasting, require a license, but nearly every employer recognizes its value. So why doesn't everyone who wants a good job in Electronics get an FCC License?

The answer: it's not that simple. You must pass a Government licensing exam. A good way to prepare for

your FCC exam is to take a licensing course from Cleveland Institute of Electronics. Our training is so effective that in a recent survey of 787 CIE graduates, better than 9 out of 10 CIE grads passed the Government FCC License exam.

That's why we can offer this famous Money-Back Warranty: when you complete any CIE licensing course, you'll be able to pass your FCC exam or be entitled to a full refund of all tuition paid. This warranty is valid during the completion time allowed for your course. You get your FCC License — or your money back!

### Praised by Successful Graduates

CIE training has been a big boost towards success for many men. Says Joseph Zauhar, Duluth, Minnesota, "I had three good job offers after I finished my CIE training and accepted a position as Technical Editor for Electronic/Technician Dealer Magazine. I've since been promoted to Managing Editor." From Cambridge, Massachusetts, Joe Perry reports, "I'm now an Engineering Specialist with National Radio Company, Inc., testing prototype equipment. CIE training gave me the electronics technology I needed to pass the exam for First Class FCC License. I'm already earning more than I could have without my CIE training."

### Approved Under G.I. Bill

All CIE career courses are approved for educational benefits under the G.I. Bill. If you are a Veteran or are in service now, check box on reply card or coupon for G.I. Bill information.

### Mail Card for Two Free Books

Want to know more? Mail the postpaid reply card for two free books about opportunities in Electronics. For your convenience we will try to have a representative call. If reply card is missing, use coupon or write to: Cleveland Institute of Electronics, Inc., 1776 East 17th Street, Cleveland, Ohio 44114.



**MAIL COUPON TODAY:**

**CIE Cleveland Institute of Electronics, Inc.**  
1776 East 17th Street, Cleveland, Ohio 44114  
Accredited Member National Home Study Council

Please send me your two FREE books:  
1. Your school catalog, "Succeed in Electronics."  
2. Your book on "How To Get A Commercial FCC License."

Name \_\_\_\_\_  
(please print)

Address \_\_\_\_\_

City \_\_\_\_\_ State \_\_\_\_\_ Zip \_\_\_\_\_

**Veterans and Servicemen:**  
 Check here for G.I. Bill information.

RE-19

Circle 20 on reader service card

ARCH GE ICC IR MAL MOT RCA SPR SYL

Model	ARCH	GE	ICC	IR	MAL	MOT	RCA	SPR	SYL
2N814	NA	GE-1	NA	IRTR-85	PTC 107	HEP-633	SK 3005	RT-121	ECG 102A
2N815	RS276-2005	GE-8	ICC-254	IRTR-85	PTC 108	HEP-254	SK 3011	RT-121	ECG 100
2N816	NA	GE-8	NA	IRTR-85	PTC 108	HEP-632	SK 3011	RT-121	ECG 102A
2N817	RS276-2004	GE-6	ICC-253	TR-08	PTC 108	HEP-253	SK 3011	RT-119	ECG 158
2N818	NA	GE-6	NA	TR-08	PTC 108	HEP-629	SK 3011	RT-119	ECG 158
2N819	RS276-2004	GE-6	ICC-253	IRTR-85	PTC 108	HEP-253	SK 3011	RT-121	ECG 102A
2N820	NA	GE-6	NA	IRTR-85	PTC 108	HEP-629	SK 3011	RT-121	ECG 102A
2N821	RS276-2002	GE-6	ICC-641	TR-08	PTC 108	HEP-641	SK 3011	RT-119	ECG 101
2N822	RS276-2002	GE-6	ICC-641	TR-08	PTC 108	HEP-641	SK 3011	RT-119	ECG 101
2N823	RS276-2002	GE-5	ICC-641	TR-08	PTC 108	HEP-641	SK 3011	RT-119	ECG 101
2N824	RS276-2002	GE-5	ICC-641	TR-08	PTC 108	HEP-641	SK 3011	RT-119	ECG 101
2N825	RS276-2005	GE-1	ICC-254	IRTR-85	PTC 109	HEP-254	SK 3011	RT-120	ECG 102
2N826	NA	GE-1	NA	IRTR-85	PTC 109	HEP-632	SK 3004	RR-120	ECG 102
2N827	RS276-2003	GE-53	ICC-3	IRTR-89	PTC 107	HEP-3	NA	RT-121	ECG 160
2N828	RS276-2003	GE-9	ICC-3	IRTR-89	PTC 107	HEP-3	NA	NA	ECG 160
2N829	RS276-2003	GE-51	ICC-3	IRTR-89	PTC 107	HEP-3	NA	RT-101	ECG 160
2N830	RS276-2009	GE-20	ICC-50	IRTR-95	PTC 136	HEP-50	SK 3122	RT-113	ECG 108
2N831	RS276-2009	GE-20	ICC-50	IRTR-95	PTC 136	HEP-50	SK 3122	RT-102	ECG 123A
2N832	RS276-2003	GE-52	ICC-3	IRTR-89	PTC 109	HEP-3	NA	RT-120	ECG 160
2N833	RS276-2003	GE-53	ICC-3	IRTR-89	PTC 107	HEP-3	NA	RT-121	ECG 160
2N834	RS276-2003	GE-53	ICC-3	IRTR-89	PTC 107	HEP-3	NA	RT-121	ECG 160
2N835	RS276-2009	GE-61	ICC-50	TR-21	PTC 121	HEP-50	SK 3122	RT-102	ECG 123A
2N836	RS276-2009	GE-61	ICC-50	TR-21	PTC 121	HEP-50	SK 3122	RT-102	ECG 123A
2N837	RS276-2009	GE-61	ICC-50	TR-21	PTC 121	HEP-50	SK 3039	RT-113	ECG 108
2N838	RS276-2009	GE-61	ICC-50	TR-21	PTC 121	HEP-50	SK 3122	RT-113	ECG 108
2N839	RS276-2009	GE-61	ICC-50	TR-21	PTC 121	HEP-50	SK 3122	RT-102	ECG 123A
2N840	RS276-2009	GE-61	ICC-50	TR-21	PTC 121	HEP-50	SK 3122	RT-102	ECG 123A
2N841	RS276-2009	GE-61	ICC-50	TR-21	PTC 121	HEP-50	SK 3039	RT-113	ECG 108
2N842	RS276-2009	GE-61	ICC-50	TR-21	PTC 121	HEP-50	SK 3122	RT-102	ECG 123A
2N843	RS276-2009	GE-61	ICC-50	TR-21	PTC 121	HEP-50	SK 3114	RT-115	ECG 159
2N844	RS276-2009	GE-61	ICC-50	TR-21	PTC 121	HEP-50	SK 3122	RT-113	ECG 108
2N845	NA	GE-18	NA	IRTR-87	PTC 125	HEP-713	NA	RT-108	NA
2N846	RS276-2003	GE-61	ICC-3	IRTR-89	PTC 109	HEP-3	SK 3123	NA	ECG 160
2N847	RS276-2011	GE-61	ICC-56	IRTR-95	PTC 121	HEP-56	SK 3039	RT-113	ECG 108
2N848	NA	GE-61	NA	IRTR-95	PTC 121	HEP-718	SK 3039	RT-113	ECG 108
2N850	NA	GE-61	NA	IRTR-95	PTC 121	HEP-718	SK 3039	RT-113	ECG 108
2N851	RS276-2011	GE-20	ICC-56	IRTR-95	PTC 136	HEP-56	SK 3039	RT-113	ECG 108
2N852	NA	GE-20	NA	IRTR-95	PTC 136	HEP-56	SK 3039	RT-113	ECG 108
2N853	RS276-2023	GE-21	ICC-52	TR-20	PTC 103	HEP-52	SK 3114	RT-115	ECG 159
2N854	RS276-2023	GE-21	ICC-52	TR-20	PTC 103	HEP-52	SK 3114	RT-115	ECG 159
2N855	RS276-2023	GE-22	ICC-52	TR-20	PTC 103	HEP-52	SK 3114	RT-115	ECG 159
2N856	RS276-2023	GE-22	ICC-52	TR-20	PTC 103	HEP-52	SK 3114	RT-115	ECG 159
2N857	RS276-2023	GE-22	ICC-52	TR-20	PTC 103	HEP-52	SK 3114	RT-115	ECG 159
2N858	RS276-2023	GE-22	ICC-52	TR-20	PTC 103	HEP-52	SK 3114	RT-115	ECG 159
2N859	RS276-2023	GE-22	ICC-52	TR-20	PTC 103	HEP-52	SK 3114	RT-115	ECG 159
2N860	RS276-2023	GE-22	ICC-52	TR-20	PTC 103	HEP-52	SK 3114	RT-115	ECG 159
2N861	RS276-2023	GE-22	ICC-52	TR-20	PTC 103	HEP-52	SK 3114	RT-115	ECG 159
2N862	RS276-2023	GE-22	ICC-52	TR-20	PTC 103	HEP-52	SK 3114	RT-115	ECG 159
2N863	RS276-2023	GE-22	ICC-52	TR-20	PTC 103	HEP-52	SK 3114	RT-115	ECG 159
2N864	RS276-2023	GE-22	ICC-52	TR-20	PTC 103	HEP-52	SK 3114	RT-115	ECG 159
2N865	RS276-2023	GE-22	ICC-52	TR-20	PTC 103	HEP-52	SK 3114	RT-115	ECG 159
2N866	RS276-2009	GE-20	ICC-50	TR-21	PTC 123	HEP-50	SK 3124	RT-100	ECG 123
2N867	RS276-2009	GE-20	ICC-50	TR-21	PTC 123	HEP-50	SK 3124	RT-100	ECG 123
2N868	NA	NA	NA	TR-21	NA	NA	NA	NA	NA
2N869	RS276-2023	GE-22	ICC-52	TR-20	PTC 103	HEP-52	NA	RT-126	ECG 106
2N870	NA	GE-18	NA	IRTR-87	PTC 123	HEP-713	NA	RT-108	NA
2N871	NA	GE-18	NA	IRTR-87	PTC 123	HEP-713	NA	RT-108	NA
2N876*	NA	NA	NA	NA	NA	HEP-R1001	NA	NA	NA
2N877*	NA	NA	NA	NA	NA	HEP-R1001	NA	NA	NA
2N878*	NA	NA	NA	NA	NA	HEP-R1002	NA	NA	NA
2N879*	NA	NA	NA	NA	NA	HEP-R1003	NA	NA	NA
2N880*	NA	NA	NA	NA	NA	HEP-R1004	NA	NA	NA
2N881*	NA	NA	NA	NA	NA	HEP-R1005	NA	NA	NA
2N884*	NA	NA	NA	NA	NA	HEP-R1001	NA	NA	NA
2N885*	NA	NA	NA	NA	NA	HEP-R1001	NA	NA	NA
2N886*	NA	NA	NA	NA	NA	HEP-R1002	NA	NA	NA

\*These devices are silicon controlled rectifiers.

(continued next month)

# R-E's Service Clinic

## replacement parts

*An exact replacement may be a must*

JACK DARR  
SERVICE EDITOR

YOU HEAR THE FACTORY MEN SAY "Always use exact duplicate replacement parts, our part number——". In a few cases, you can find suitable substitute replacements. In others, brothers, you'd *better* use the factory replacement part. If you don't, you can "build-in" a real stinker of a problem. I ran into a couple of very good examples not too awfully long ago, to illustrate this point.

The subject was a Magnavox T933, which showed only blue, and a little green. It had been worked on just before I got it; complaint "wrong colors". So, I ran a gray-scale on it, and after forgetting that in these sets you must set the screens with the brightness control turned *off*, got a fairly decent monochrome picture. No color at all.

Up bar-dot generator and at 'em. Now I've got color all over the place. Take bar-dot off, hook up antenna, fine color picture. What happened? Oh, oh. Intermittent. Turn off, cool, turn on—no color now. Up scope. Touch plate of 3.58-MHz oscillator tube with probe. Pow! Color again, and oscillator signal. Repeat test, with same results. Turn off, cool, no color, apparently due to loss of oscillator signal. Touch *anything* in the circuit, and the oscillator starts.

Now sit there and think of a really clever way of checking this without touching it. OK: place the scope-probe near, but not touching, the plate. Recheck. No oscillator. Wait. No signal, after several minutes. The oscillator will *not* start by itself. Touching the plate, even with the tip of a pencil, starts it, and it's right on the money.

Try running the regular oscillator setup tests. These produce very odd results, and the oscillator still won't start. Maybe this is the crystal. Oscillators refuse to start because of insufficient feedback, and in this one, the crystal is the main element in the feedback loop.

Having a couple of crystals on the bench, I try one. Same problem. Try

another crystal; Same, only worse this time. Find brand-new crystal, for Motorola replacement. Try this. Hmm. Won't work either. OK, try the acid test; go down the street to the Magnavox dealer, and get the right crystal.

Put this in, turn it on and presto. It works. Run the setup adjustments, and everything is copasetic. For a recheck, I tried the Motorola crystal once more, and one of the others. Same thing; they won't work. So I make a resolution. When I see what I suspect will be crystal trouble, from now on I will always use the *right* one! There are enough differences in circuitry, constants, and so, so that the wrong crystal will refuse to work, or won't work as it should!

That got the color problem. However, while working on that, I'd noticed some odd beats, etc, on the screen. I ignored these, since they didn't seem to be associated with the color problem, and weren't. Now I went after them. The tuner was apparently oscillating; low-band stations were OK, but on the high bands the thing was as hot as a pistol. Touch the lead-in at any point, on high-band stations, and the picture went all to pieces.

This is ordinarily due to improper neutralization, in the "Neutrode" tuners. I'd seen it in certain RCA tuners, and cleared it up by readjusting the neutralization. However, this one didn't *have* a neutralization adjustment. Let's try a new rf tube. Pull the tube, which is a brand-new one. Hmm. Tube layout calls for 6HQ5, and this one is a 6HA5.

On a hunch, I got a 6HQ5 and tried it. Perfect. No oscillation, no squiggles, nothing. Put the 6HA5 back, here we go again. Apparently, this "substitute" tube had just a little bit *too much* gain, making the tuner unstable. Installing the correct tube type fixed the whole problem.

So: the moral of this is that if you must substitute for any part, check the set's *performance* after the replacement is in. *This* is the final cri-

This column is for your service problems—TV, radio, audio or general and industrial electronics. We answer all questions individually by mail, free of charge, and the more interesting ones will be printed here.

If you're really stuck, write us. We'll do our best to help you. Don't forget to enclose a stamped, self-addressed envelope. Write: Service Editor, Radio-Electronics, 200 Park Ave. South, New York 10003.

terion. I have substituted one tube type for another, with good results. I have substituted a lot of transistors for the original types, also with good results. I have also tried substitute transistors and tubes, and found out that they wouldn't work satisfactorily.

For one final weirdo, A Zenith 14N22 had a severe case of vertical jitter. Full, linear raster, all control reactions normal, plenty of sync, etc., but it jittered. (Did not suspect the tube, because of full raster, etc.) The scope showed an odd pattern on the output waveform of the vertical integrator (see diagram). There was a tiny glitch on the scan portion of the

waveform. This was intermittent.

After checking all of the parts I could think of, and replacing the sync separator and integrator. I went to the

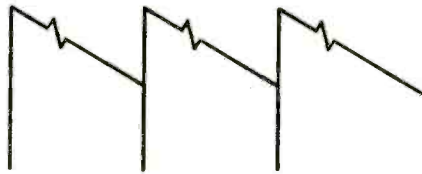

Zenith dealer and got a 6FM7 tube (as usual, I didn't have the one I wanted). Try this. No jitter! No glitch on the waveform. Put the original tube back. Jitter again. Get still an-

other 6FM7 tube; no jitter.

This one, I am *not* going to try to explain, for I have no idea of the cause. However, that one particular 6FM7 tube *would* cause the jitter, and the others wouldn't. There are "fixes" given for this, including adding a diode in the oscillator cathode, but these had no effect. The jittering tube checked perfect, of course.

So when you run into mysterious symptoms like these, try a new tube, or better still, a couple of new tubes, and see if this won't help. Even though the original seems to check out perfectly, and works almost normally, try some more tubes. Sometimes, it pays! **R-E**

# profits grow

when you use **RCA** SERVICE DATA



**QUICK REFERENCE and RELIABLE INFORMATION saves time and makes money**

- A SUBSCRIPTION INCLUDES A COMPLETE "FILE" YEAR OF:
- COLOR TELEVISION DATA
  - B & W TELEVISION DATA
  - RADIO DATA
  - PHONOGRAPH DATA
  - TAPE RECORDER DATA
  - SERVICE TIPS
  - PARTS TIPS
  - PERIODICAL ISSUES OF "PLAIN TALK"
  - "GOLDENROOD" BULLETINS
  - SERVICE DATA INDEX



**DON'T DELAY! SUBSCRIBE TODAY!**

Please acknowledge my request for a Service Data Subscription:

- "File-1973" Service Data including 3 binders \$25.45
- "File-1973" Service Data subscription \$16.00
- (Binders available separately—\$3.15 each) Number desired \_\_\_\_\_
- Previous Years Data (\$13.50 per set) 72  71  70  69  68  67  66

Amount enclosed: \$ \_\_\_\_\_

NAME \_\_\_\_\_

STREET ADDRESS \_\_\_\_\_

CITY \_\_\_\_\_ STATE \_\_\_\_\_ ZIP CODE \_\_\_\_\_

Your order will be processed promptly upon receipt of your check or money order in the amount indicated above.

SEND TO: **RCA CONSUMER ELECTRONICS** 600 N. Sherman Dr., Indianapolis, Ind. 46201

ATTN: Technical Publications, I-450 (Or Contact Your Local Distributor)

NOTE: Prices Subject To Change Without Notice

Circle 16 on reader service card

## reader questions

### DOUBLE PIX

*This Olympic NPD chassis makes nice pictures—two of them side by side! Just as stable as can be. Horizontal hold, horizontal oscillator coil won't bring it to a single picture, although both show normal "effects". Shorting the afc, you can adjust for a single picture, remarkably stable for no sync!—I.D., Mattoon, Ill.*

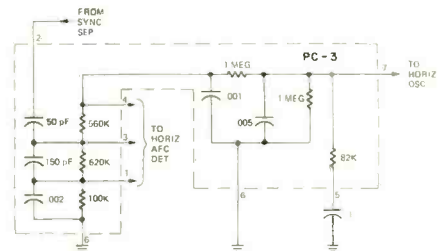

Afc trouble, as you thought. Look for an open bypass capacitor in that Res-Cap unit, PC-3 in the Sams diagram. Most likely suspect, the .002- $\mu$ F at the bottom of the dual-diode network, between terminals 1 and 6. Bridge one across it, externally. If this makes the set hold, you won't have to replace the whole thing.

### SMALL RASTER

*I've got an odd condition on this Sylvania D-12. The raster is pulled in on all sides. My B+ is OK at about +320 volts. However, I get +220 volts on the screen grid of the 6LR6, and almost -90 volts on the control grid. Should be -45 volts on the control grid and +120 on the screen. The High Voltage Adjust control has no effect, but I've got 20 kV.—D.M.S., Tucson, Ariz.*

Try a new 6BK4 regulator tube. In the older circuits, this wouldn't have the same effect. However, this (continued on page 70)

# Don't give in to temptation!



At Channel Master we realize how tempting it is to reuse the old blue lateral and purity ring assembly when you're replacing CRT's. The old part may look OK, or a new one may not be handy---so why not?

Because it's a sinful waste of time! The magnets that are vital to purity and convergence are often too weakened to even do the job.

So Channel Master has put temptation out of reach, and put a new blue lateral and purity ring assembly right at your fingertips---on the neck of every 90° Color CRT! The new part comes free to help you do the job faster and easier, and maintain the tube's peak operating performance longer!

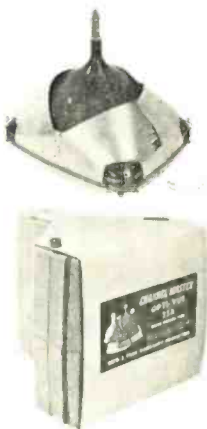

The blue lateral and purity ring assembly is only one part in our big plan to make your work easier.

Others are:

- Channel Master Speed-Fit CRT's ---with preassembled hardware that cuts installation time as much as 40 minutes!
- Channel Master Foam Pak Cartons---that make CRT's easier to handle, store and transport!

At Channel Master we want to make life a Garden of Eden for the Independent Service Dealer. And if we have to remove all temptation to do it---we will!

**CHANNEL MASTER**  
**PICTURE TUBE HEADQUARTERS**

ELLENVILLE, NEW YORK 12428

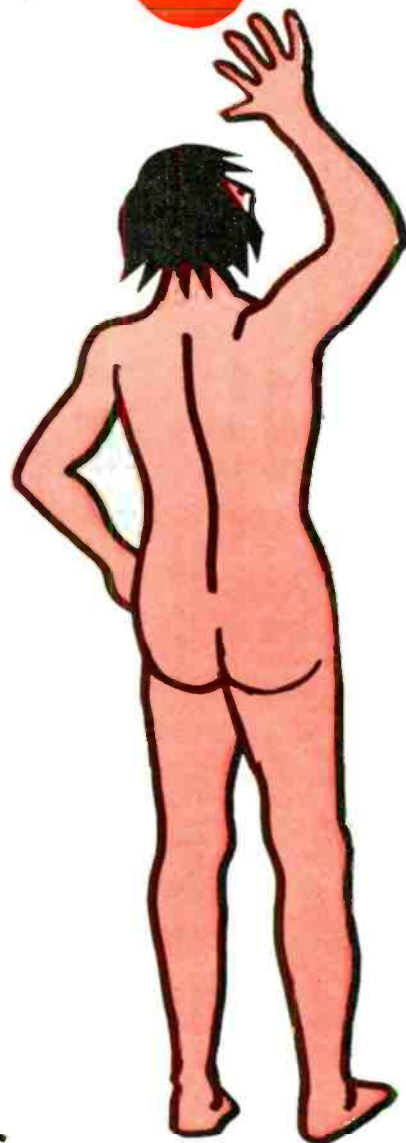

**READER QUESTIONS**  
(continued from page 68)

chassis has a "High-Voltage Hold-down" circuit, as required by HEW. Failure in the high-voltage regulator will reduce or cut off the high voltage to prevent radiation. In "marginal" cases, it will just make the raster shrink.

**RESISTOR BURNOUT**

The 1500-ohm resistor in the first i.f. cathode circuit, in a Zenith 15L33 chassis, burns up. I've changed the tubes, and checked all resistors; no luck.—B.T., Delta, Ia.

This sounds a little "basic", but the resistor is carrying too much current! (Sorry about that, but it's true.) Since the only thing that causes current-flow in this resistor is the tube, something must be wrong there.

Not the tube itself, since it's been replaced. So, this leaves us only one thing—the grid bias. If this is "too far positive", the tube will draw excessive plate current. These little frame-grid tubes can handle surprisingly high currents, with incorrect bias.

The bias for this tube comes from the agc. Check the cathode voltage, and the control grid voltage. Note the high "offset" cathode voltage (see dia-

gram). The cathode is +42 volts, from ground, but the grid is +35 volts. These are no-signal voltages. So, the net bias on this tube is -7 volts.

If something is wrong in the agc which lets the grid go more positive, it will cause the tube to draw a heavy

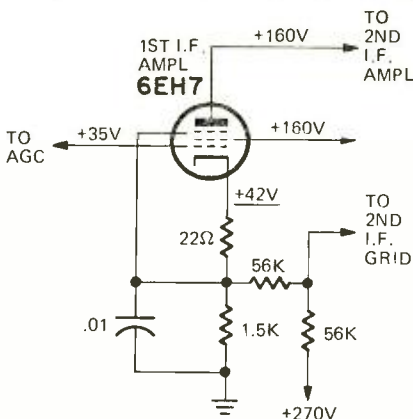

plate current and burn up the cathode resistor. (In case anyone is wondering about why the 22-ohm resistor doesn't burn up, too, it's easy. It's so little that it doesn't develop the I<sup>2</sup>R drop (power) across it that the 1500-ohm one does!)

**NO CONTRAST, SYNC BAD**

I've got several problems in a GE LY chassis. The picture is so weak I

can hardly see outlines, the sound buzzes, and the agc isn't working.—G.R. Greensboro, N.C.

Whenever you find a mess of "multiple symptoms" such as this, look for a common cause. In this instance, I'd say the video detector was bad. Note that it not only supplies video to the output stage, but also to the sync separator and agc stages. Without the proper video signal, none of these will work.

Check the signal level at the video detector output with a scope. Should be about 1.5 volts p-p at this point, and show good clean sync. To check the video output stage look at the signal on the pix tube cathode; it should have about 50 volts p-p here. Also, check video on sync and agc stages.

**THE MISPLACED POINT**

The picture won't stay in horizontal sync on this Motorola TS-597. The hold control is supersensitive; pix falls out just the second you move it. I tried new capacitors across the horizontal oscillator coil/hold control. If I use the 0.22 μF on the lower half, as shown in the schematic I have, it won't oscillate at all!—C.C., Johns Island, S.C.

Two things here. The "0.22 μF" capacitor across the coil should be a

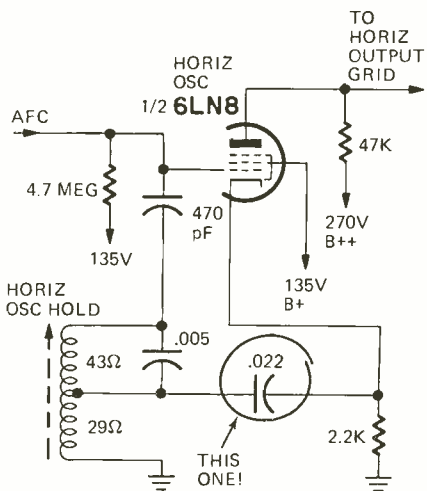

0.022 μF. Someone has moved a decimal point. Incidentally, when replacing these capacitors, be very sure that you get the right one across each section of this coil. You can get some strange and wonderful effects by reversing them.

Two: your oscillator is working. This is an afc problem, if it won't hold. Check the dual diode unit, and the 150-pF sync coupling capacitor.

**TUNER PROBLEM**

The tuner on this Zenith 16Z7C50Z has one of the funniest problems I've ever seen. I get Channel 7 on the 6 setting, and so on all up the line.

(continued on page 76)

**Now...the most enjoyable do-it-yourself project of your life—a Schober Electronic Organ!**

You'll never reap greater reward, more fun and proud accomplishment, more benefit for the whole family, than by assembling your own Schober Electronic Organ. You need no knowledge of electronics, woodwork or music. Schober's complete kits and crystal-clear instructions show you—whoever you are, whatever your skill (or lack of it)—how to turn the hundreds of quality parts into one of the world's most beautiful, most musical organs, worth up to twice the cost of the kit.

Five superb models with kit prices from \$500 to around \$2,000, each an authentic musical instrument actually superior to most you see in stores, easy for any musically minded adult to learn to play, yet completely satisfying for the accomplished professional. And there are accessories you can add any time after your organ is finished—lifelike big auditorium reverberation, automatic rhythm, presets, chimes, and more.

Join the thousands of Schober Organ builders—owners who live in every state of the Union. Often starting without technical or music skills, they have the time of their lives—first assembling, then learning to play the modern King of Instruments through our superlative instructions and playing courses.

Get the full story FREE by mailing the coupon TODAY for the big Schober color catalog, with all the fascinating details!



The Schober Organ Corp., Dept. RE-115  
43 West 61st Street, New York, N. Y. 10023

Please send me Schober Organ Catalog.  
 Enclosed please find \$1.00 for 12-inch L.P. record of Schober Organ music.

NAME \_\_\_\_\_  
ADDRESS \_\_\_\_\_  
CITY \_\_\_\_\_ STATE \_\_\_\_\_ ZIP \_\_\_\_\_

Circle 18 on reader service card



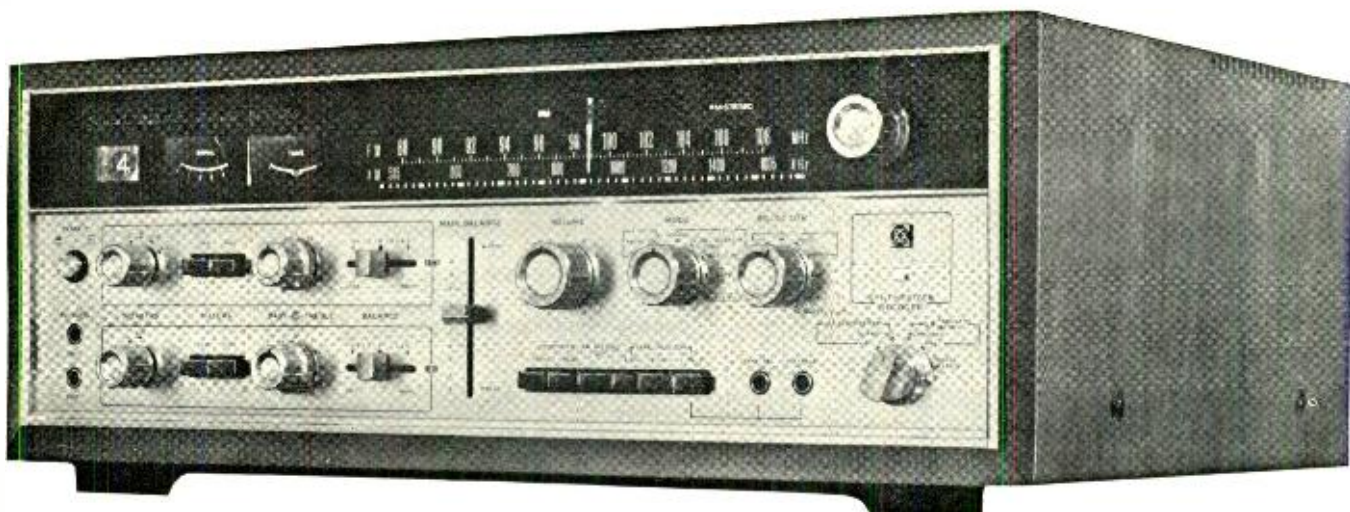

Sansui QRX-6500 four-channel receiver

# The already famous Sansui QS vario matrix is here. In the new Sansui QRX-6500.

You may have already heard about the vario matrix we invented. It is a recognized achievement in four-channel technology. Proof of its tremendous effectiveness is the fact that already attempts are being made to copy or simulate it.

Sansui has not only pioneered in this development; we are also the only company to make the vario matrix available to your customers *now*.

This means listeners can now have quadraphonic reproduction with such great separation that some people are calling our system the "discrete matrix". And it's incorporated in two superb new Sansui four-channel receivers: the QRX-6500 and QRX-3500. Both feature:

- generous power output (280 watts IHF for the 6500)
- QS vario matrix, plus phase matrix
- two-position four-channel synthesizer
- sound field rotation; 10-speaker system capacity
- sensitive FM/AM tuner sections
- easy-operating controls
- unitized design

The most advanced four-channel receivers with the most advanced four-channel decoding circuitry: Sansui's great new QRX series. They make quadraphonic reproduction something your customers can never forget.



## SANSUI ELECTRONICS CORP.

Woodside, New York 11377 • Gardena, California 90247

ELECTRONIC DISTRIBUTORS, Canada,

SANSUI ELECTRIC CO., LTD., Tokyo, Japan • Sansui Audio Europe S. A., Antwerp, Belgium

Circle 19 on reader service card

# IF YOU CAN USE ANY OF THESE TOOLS...



**...you could build a whole new future...**

**and build  
yourself  
a Bell & Howell  
solid state  
color TV while  
you're at it!**



If you're already handy with a set of tools, here's a way to pick up a pretty thorough knowledge of electronics: build yourself a solid state color TV as part of a complete learn-at-home program from Bell & Howell Schools.

This important project gives you valuable "hands on" experience with solid state circuitry—the kind of *practical* experience you'll need to build a successful career. It's a vital part of your total electronics education.

Once you've completed your program in home entertainment electronics, you could have an exciting career opportunity waiting for you in the growing field of home entertainment electronics. You might even end up with a business of your own in color TV servicing.

#### Fix stereo systems . . . FM-AM radios . . . phonographs . . . tape recorders

With your new skills, you can build and service stereo-hi-fi systems—including FM-AM radios . . . phonographs . . . open reel tape recorders and cassette or cartridge player/recorders. You could even build yourself a complete "home entertainment communications center"—complete with the new gadgetry of cartridge television when it comes out. The skills you build up by following this brand-new program are more than enough to service almost *any* type of home entertainment electronic device.

#### A complete at-home learning program in home entertainment electronics

Don't confuse this program with an ordinary hobby kit. It's much more than that. It's a complete at-home learning program prepared by skilled instructors at Bell & Howell Schools.

It doesn't matter if you've never had any training in electronics before. Nobody's going to start throwing "diodes" and "capacitors" at you right off. You start with the basics. You take it one step at a time. You walk before you run. And you'll be amazed at how quickly you start to feel comfortable with things that seemed complicated at the beginning.

#### Attend special "help sessions" if you like

In case you should run into a sticky problem or two—one that you can't handle on your own—come in and see us. We've scheduled help sessions every few Saturdays at the Bell & Howell Schools and in many other cities throughout the U.S. and Canada. Drop by. Meet an expert instructor in person. Talk over any rough spots with him—and with other students. You'll enjoy the chance to "talk shop."

#### Master the most up-to-date solid state circuitry

Solid state is here to stay. Not just color TV but almost every type of electronic device will eventually move farther and farther in the direction of *total* solid state circuitry. Get to know the most advanced "trouble-shooting" techniques for these sophisticated circuits. You'll find an almost irresistible demand for your skills.

#### Why you should know electronics

No matter where you look, the amazing

technology of electronics is becoming a bigger and bigger part of the picture. More and more automotive parts and diagnostic instruments are electronic. Many large manufacturing plants use sophisticated electronic systems—controlled by a few skilled electronics technicians. The increasing use of two-way radio . . . the huge promise of cable television . . . the astonishing growth of electronic data processing all open doors to exciting new career opportunities for the man with thorough training in electronics. In fact, the day may come when the man who does *not* have electronic skills will be severely handicapped in many industries.

#### Why you should get your training from Bell & Howell Schools

Skilled instructors at Bell & Howell Schools—carefully selected for their knowledge, experience and teaching ability—plan each program with the utmost care and attention. Each year, they spend about \$200,000.00 improving programs and materials and keeping them in step with new developments in electronics. Thousands of people have used their Bell & Howell Schools training as the foundation for new careers and businesses of their own in electronics.

#### You build and keep the exclusive Bell & Howell Schools Electro-Lab®—a complete laboratory-in-the-home

To make sure you get practical experience with instruments used daily by professionals, you build and keep a Design Console, an Oscilloscope and a Transistorized Meter (see details at right). These are the three instruments you'll work with constantly—both during your program and thereafter.

#### CONSIDER THESE ADVANTAGES:

**Help Sessions** We've scheduled "help sessions" every few Saturdays at the Bell & Howell Schools and in many other cities throughout the U.S. and Canada. Top instructors give you expert guidance and you meet other students, too.

**Resident Study** After you complete your program, you can transfer to any of the resident schools for more advanced study, if you wish.

**Lifetime National Placement Assistance** When you complete your course, we help you locate a position in the field of Electronics that fits your background and interests. This unique service is available at any time after you graduate.

**Veterans' Benefits** We are approved by the state approval agency for Veterans' Benefits. Check the box for details.

**Student Financial Aid** We are an eligible institution under the Federally Insured Student Loan Program. Check the box for details.

## Detach postage-paid reply card and mail today for free information



25-inch picture (measured diagonally)

■ **Bell & Howell Solid State Color TV.** Ultra-rectangular tube . . . 25-inch picture measured diagonally . . . full 315 sq. inch viewing area. Solid state modular circuitry . . . 4 advanced IC's . . . 100 transistors . . . 72 diodes . . . individual plug-in circuit boards. Special UHF/VHF tuning features . . . built-in self-service components.

■ **Design Console** Use this to rapidly "breadboard" circuits without soldering. Equipped with built-in power supply . . . test light . . . speaker . . . patented plug-in modular connectors.

■ **Oscilloscope** Portable 5-inch wide-band oscilloscope offers bright, sharp screen images . . . calibrated for peak-to-peak voltage and time measurements . . . 3-way jacks for leads, plugs, wires.

■ **Transistorized Meter** Combines most desired features of vacuum-tube voltmeter and quality multimeter. Registers current, voltage and resistance measurements on a large, easily-read dial. Features sensitive, 4-inch, jewel-bearing d'Arsonval meter movement.

## For Free Information, Mail Card Today!

If card has been removed, write:

An Electronics Home Study School

DE VRY INSTITUTE OF TECHNOLOGY

ONE OF THE

**BELL & HOWELL SCHOOLS**

4141 Belmont, Chicago, Illinois 60641

**READER QUESTIONS**

*(continued from page 70)*

**Fine tuning seems to be OK. You can't get Channel 7 on 6, or can you?—T.S., Wickes, Ark.**

Nope. The cure for this is simple. Look at the back of the tuner. The indicator is driven by a small plastic pinion gear, spring-loaded, and a large plastic gear on the tuner shaft. This little gear can slip, skip a few teeth, and then your dial says channel 6 when the tuner is really on 7! Just lift the little gear against the spring, move the indicator to the right number, and

let go.

It is possible to fine-tune another channel, especially on the high bands; 9 on 10, etc. Most fine tuners have this much range. However, if the dial is one number off all the way around, look for mechanical trouble.

**TRAPEZOID RASTER**

*I've never seen a case like this! The raster on this Olympic CT-910 is distorted, as in the drawing. The scan lines pull off and up to the top left corner of the screen. If I adjust controls to make the raster smaller, it shows the same shape. Varies with brightness.—J.H., Pittsburgh, Pa.*

This is a rare one. I've seen it happen only twice (Once on my own set!) This problem is almost certainly due to an open connection inside the picture tube—to the ultor button. The inside coating of dag has broken loose. The high voltage arcs across the gap, and apparently creates a mag-

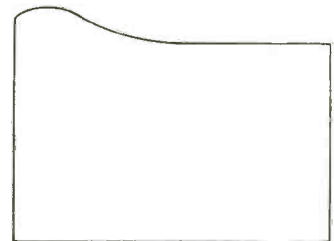
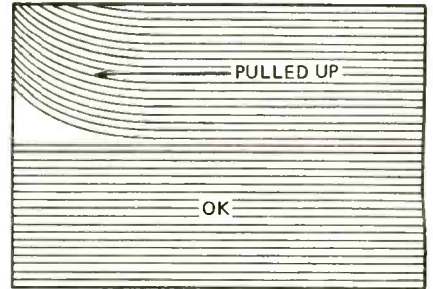

RASTER

netic field which causes the pulling up of the raster lines.

Check: wipe the glass clean around the ultor connection. Now darken the room, and turn the set on. If this is the trouble, you'll see tiny arcs, very obviously inside the glass, usually all the way around the ultor button. A new tube is the only cure.

**FLYBACK RESISTANCE DIFFERENT**

*I've just replaced the flyback in an RCA CTC-17X. Works very well, but my cathode current on the 6JE6 is running 230 mA, and I can't get it below that. Horizontal efficiency coil dipped, high-voltage regulator current about 1.4 mA, boost OK, and so on.*

*I used a well-known replacement flyback. I noted that the resistance of the high-voltage winding is given as 660 ohms, and this one is only 500 ohms. Would you suspect a short, or something like that?—H.B., Hayward, Calif.*

Under these circumstances, no. I can't see a short in the high-voltage winding with only 230 mA of cathode current in the 6JE6. This is too close to being in the ball-park. I'd say that the lower resistance of this winding could be due to the use of slightly larger wire; if your high-voltage is up to normal, etc. then the inductance almost has to be correct.

For the excessive current, check the "High-Low" ac line switch. It might be in the wrong position. **R-E**

**Will you be prepared to handle his business when it comes your way?**



...remember... there's an Amperex replacement tube for any socket in any set you're likely to service. TV, Hi Fi, FM or AM, House Radio, Car Radio, P.A. System or Tape Recorder. Imported or Domestic!

**Amperex®**

TOMORROW'S THINKING IN TODAY'S PRODUCTS  
A NORTH AMERICAN PHILIPS COMPANY



AMPEREX ELECTRONIC CORPORATION, DISTRIBUTOR AND ENTERTAINMENT PRODUCTS DIVISION, HICKSVILLE, N. Y. 11802

# Radio Shack Solid State Math!

# 29 TRANSISTORS

Equal

# 15000 TRANSISTORS!

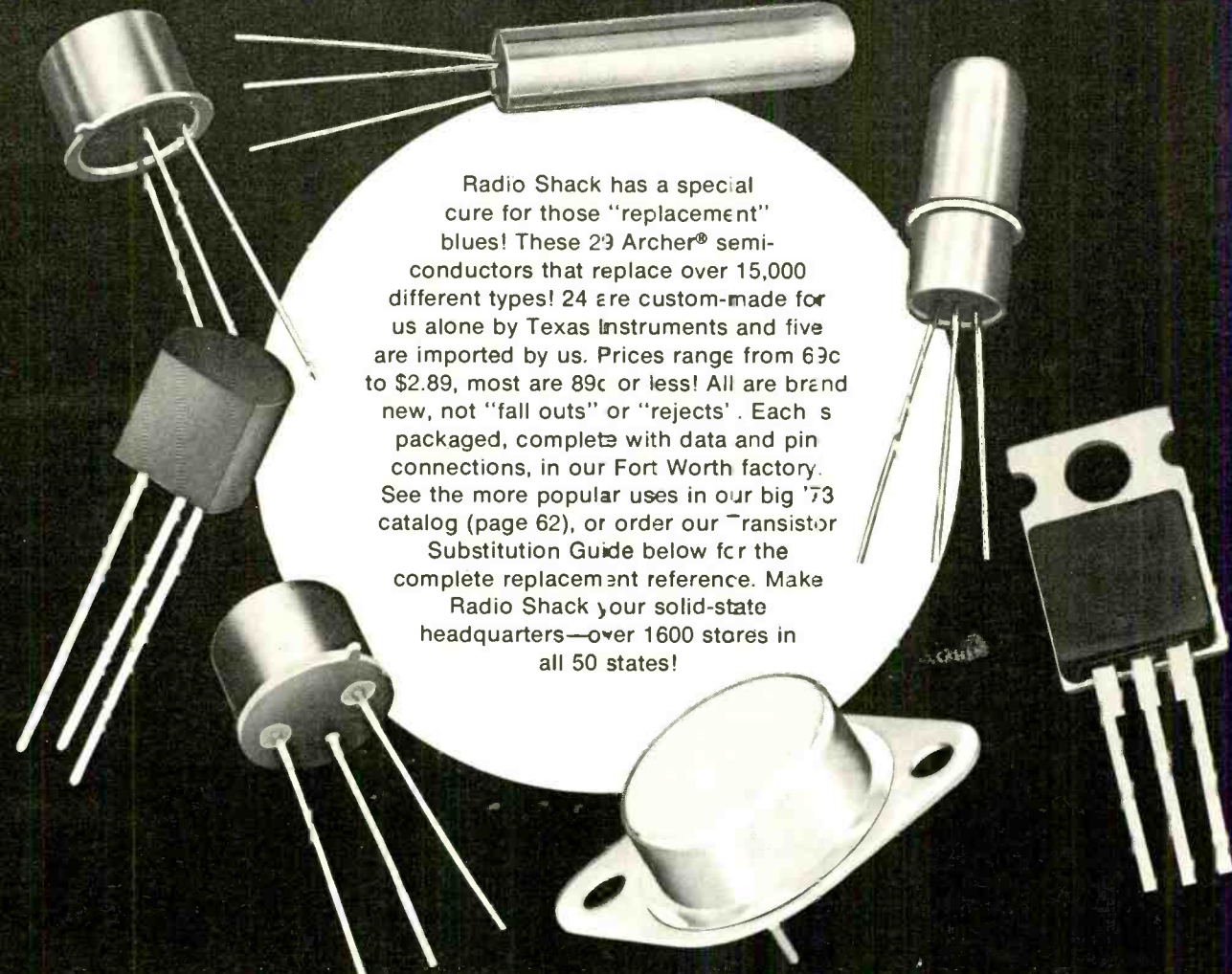

Radio Shack has a special cure for those "replacement" blues! These 29 Archer® semi-conductors that replace over 15,000 different types! 24 are custom-made for us alone by Texas Instruments and five are imported by us. Prices range from 69c to \$2.89, most are 89c or less! All are brand new, not "fall outs" or "rejects". Each is packaged, complete with data and pin connections, in our Fort Worth factory. See the more popular uses in our big '73 catalog (page 62), or order our Transistor Substitution Guide below for the complete replacement reference. Make Radio Shack your solid-state headquarters—over 1600 stores in all 50 states!



Dept. LB., 186  
 2617 W. 7th St., Fort Worth, Texas 76107

Rush me \_\_\_\_\_ Archer Transistor Substitution Guides at \$1.00 each postpaid (plus applicable sales taxes).

Check or money order for \$ \_\_\_\_\_ enclosed.

Send FREE Catalog

Please PRINT Clearly.

Name \_\_\_\_\_ Apt. # \_\_\_\_\_

Street \_\_\_\_\_

City \_\_\_\_\_ State \_\_\_\_\_ Zip \_\_\_\_\_

**Radio Shack®**  
 and ALLIED RADIO STORES  
 A TANDY CORPORATION COMPANY  
 P. O. Box 1052, Fort Worth, Texas 76107

Circle 21 on reader service card

# You'll have the answer with SK3018.

Because it's the right replacement for over 2,800 different solid-state devices. And we've got the information that shows you how. Just ask your RCA Distributor for the new SK Replacement Guide SPG-202N. It cross-references the complete RCA SK line of 156 devices to more than 51,000 types they will replace.

RCA Electronic Components  
Harrison, N.J. 07029

**RCA** Electronic Components



## 11 WAYS TO TEST IC'S (continued from page 43)

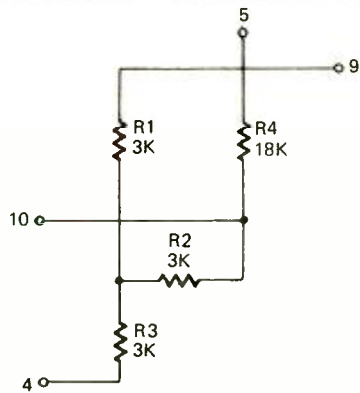

FIG. 3—EQUIVALENT CIRCUIT of the HEP 590 when low-power resistance measurements are made. The test voltage is too low to turn on the transistors.

is considerably greater than the normal junction resistance of Q2, it adds substantially to the junction-resistance value. However, 3,000 ohms has no practical effect on the reverse-resistance measurement.

**Note:** A junction resistance is different from a fixed resistance, in that the effective value of a junction resistance depends upon the value of applied voltage. Therefore, junction resistances cannot be added and subtracted like fixed resistances. In the foregoing test, the effective value of the junction resistance is about 500 ohms, but with some other value of series resistance in a circuit, the effective value of the junction would change more or less. Test 7 actually provides no new data—it is included at this point merely for instruction.

### 8. CHECKING A CONTROL-ACTION TEST OF A TRANSISTOR IN AN INTEGRATED CIRCUIT

**Equipment:** Hi-Lo FET meter.

**Connections:** Same as in test 1.

**Procedure:** Set meter controls to operate on its high-power ohms function and the  $R \times 1$ -MEG range. Referring to Fig. 2, apply the positive test lead to terminal 10, and apply the negative test lead to terminal 2. Note scale indication. Then, touch your finger to terminal 1 and note any change in the scale indication.

**Evaluation:** This is basically a control-action test for transistor Q3. That is, the test voltage is polarized so that the base-emitter junctions of Q1 and Q2 conduct. However, since Q3 is cut off when its base connection is open, the ohmmeter normally reads infinity. But when you touch your finger to terminal 1, Q3 is driven by

stray hum voltage. Accordingly, Q3 conducts on the positive peaks

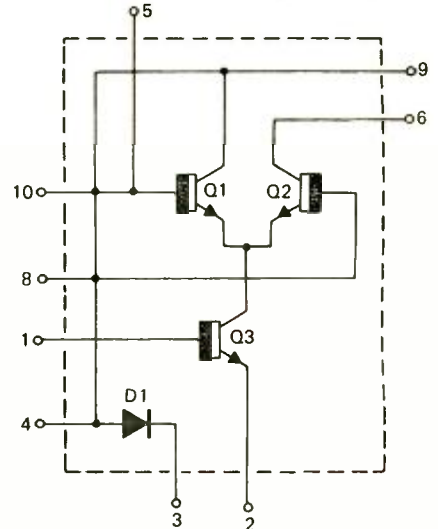

FIG. 4—EQUIVALENT CIRCUIT for transistor test with all junctions as open circuits. Resistance measurements less than infinity show IC is bad.

of the drive voltage, and the ohmmeter reading normally decreases. If this general type of response does not occur, the IC is defective.

**Note:** The exact amount of decrease in resistance reading will vary in the foregoing test, depending upon how much hum voltage your body is picking up. If you are close to ac wiring, the hum level will be comparatively high. Note that stray hum voltage may impose a limitation on the tests that can be made on high-gain IC's. That is, if the test situation is favorable to amplification of the hum voltage picked up by the IC terminals, the test results can be erroneous.

### 9. CHECKING AN INTEGRATED CIRCUIT FOR INTERMITTENTS

**Equipment:** Hi-Lo FET meter.

**Connections:** Same as in test 1.

**Procedure:** Same as in any foregoing test, except that the IC is tapped while the measurement is being made.

**Evaluation:** If the pointer "jumps" on the scale, it indicates that the IC is intermittent and should be rejected. (Be sure that your test connections are tight.)

### 10. TESTING AN INTEGRATED CIRCUIT FOR CURRENT DRAIN

**Equipment:** Hi-Lo FET meter.

**Connections:** This test is made with the IC wired into its normal circuit, such as an i.f. amplifier shown in Fig. 2. Disconnect the lead from terminal 9 of the IC; this is the supply-voltage lead. Connect the meter leads between

(continued on page 80)

# JERROLD HAS TAKEN THE MYSTERY OUT OF MASTER ANTENNA TV.

Now, you don't have to worry about decibels or any other theory. Just pick out one of the Universal Systems shown in the Jerrold Instant MATV Guide, install it and you have an excellent system.

If you can deliver good TV signals to one set from one antenna, you can easily install any system in this guide.

Complete with actual Layouts, Bills of Materials and Installation Tips.

Send for your Jerrold INSTANT MATV Guide today.

## IT'S FREE!

**JERROLD ELECTRONICS CORPORATION**  
P.O. BOX 350, 200 WITMER ROAD, HORSHAM, PA. 19044

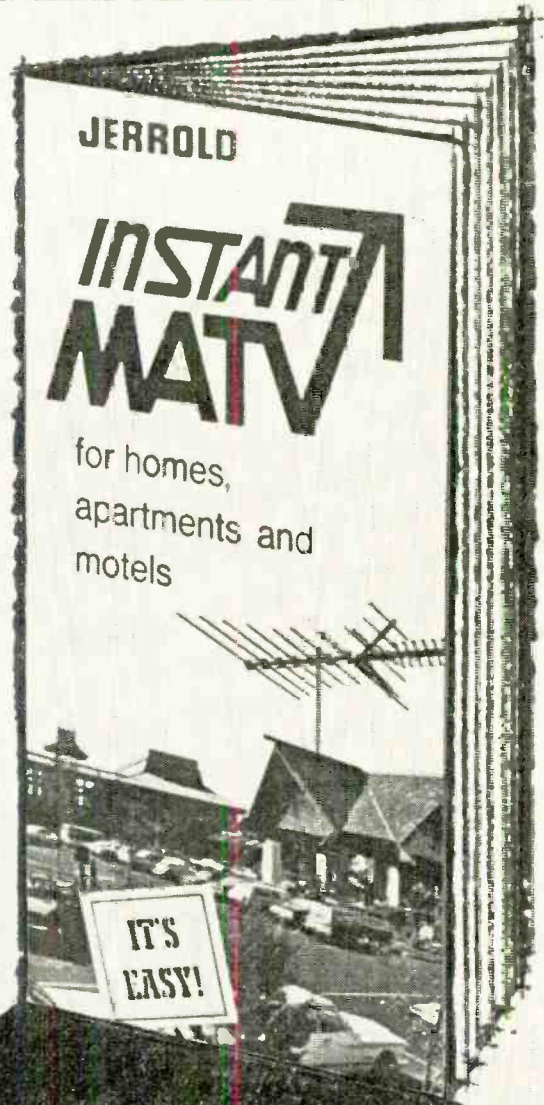

Circle 22 on reader service card

## 4 BOARD SPECIAL



4 boards out of late RCA & Honeywell computers. Most all kinds of electronic parts. Transistors, integrated circuits, resistors, capacitors, trim pots and at least 4 RCA 198034/2N3055 power transistors. A parts bonanza.

STOCK NO. J9555 set of 4 \$3.75  
2 sets, \$7.00 3 sets \$10.00



### RECHARGEABLE BATTERIES

6 volt 6 amp. hour, 2 1/4" x 3 3/4" x 5 1/2".  
1.5 volt 2 amp. hour, (Mallory SA-13D), Size D. Both batteries ideal for portable equipment, burglar alarms, emergency lighting etc. Comes with complete data for charging, and suggested chargers.

STOCK NO. J5155 6 volt battery  
\$5.95 ea. 2/10.00

STOCK NO. J5156 1.5 volt battery  
\$1.25 ea. 4/4.50

NEW COMPUTER GRADE CAPACITORS  
40,000 Mfd. 10 volts 1.25 ea. 6/7.00 No. J2026  
70,000 Mfd. 10 volts 1.75 ea. 6/9.00 No. J2118  
32,000 Mfd. 40 volts 2.00 ea. 6/11.00 No. J2210  
3,750 Mfd. 75 volts 1.75 ea. 6/9.00 No. J2116

Include sufficient postage, excess refunded. Send for new 48 page catalog, loaded with bargains. MINIMUM ORDER \$3.00



**DELTA ELECTRONICS CO.**

BOX 1, LYNN, MASSACHUSETTS 01903  
Phone (617) 388-4705

Circle 23 on reader service card

## 11 WAYS TO TEST IC's (continued from page 78)

terminal 9 and the supply-voltage lead.

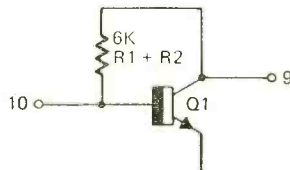

FIG. 5—FRONT-TO-BACK TEST of transistor Q1's collector-base junction finds this equivalent circuit in the HEP 590.

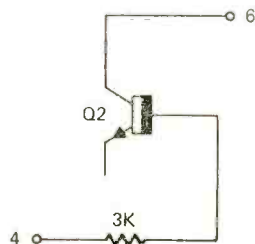

FIG. 6—SERIES RESISTANCE is part of equivalent circuit of Q2's collector-base junction in Motorola HEP 590 IC.

**Procedure:** Operate the meter on its DC CURRENT function, and measure the current flow into the IC.

**Evaluation:** Compare the measured current value with the rated cur-

rent value for the given supply voltage, as specified in the IC manual. If there is a substantial discrepancy, a defect is indicated in the IC or in its associated external circuitry.

## 11. TESTING OPERATING VOLTAGES AT IC PINS

**Equipment:** Hi-Lo FET meter.

**Connections:** This test is made with the IC in its normal circuit, such as an i.f. amplifier as in Fig. 2. The meter test leads are applied between each of the IC terminals in turn and the common bus.

**Procedure:** Operate the meter on its DC VOLTS function, and measure the voltage value at each terminal.

**Evaluation:** Compare the measured voltage values with those specified in the receiver or equipment service data. If the corresponding values are in substantial discrepancy, there is a defect in the IC or in its associated external circuitry. Note that when service data are not available, it may be possible to make a comparison test on a similar IC in another stage, such as in first and second i.f. amplifiers.

R-E

## Zo-o-o-o-m-m-m

First in the race. Raytheon put together the car. You drove it to top money in the big '72 season. It's a money-making team that started with your switch to Raytheon, the largest independent tube supplier. We know the competition is rough. As an independent serviceman, you can't waste time and money on call backs or pit stops. So, Raytheon builds to beat the competition. You drive hard for first place. And we're going for the trophy again this year. Together.



Circle 24 on reader service card





# Everything you need to know to service practically everything electronic

## 1-2-3-4 SERVING STEREO AMPS

by Forest H. Belt  
A complete guide to servicing the latest transistor audio circuits. It follows the logical 1-2-3-4 step-by-step procedure that avoids false starts and "blind alleys" in searching out defects in performance. 240 pages.  
No. 20912 .....\$4.95

## 1-2-3-4 SERVING TRANSISTOR COLOR TV

by Forest H. Belt  
Follow the 1-2-3-4 method outlined in this guide and get the repair job done easily and right the first time. Covers latest color-tv circuitry from problem diagnosis to repair. 264 pages.  
No. 20777 .....\$4.95

## 1-2-3-4 SERVING AUTOMOBILE STEREO

by Forest H. Belt  
Explains and shows how to apply the easy 1-2-3-4 method to auto stereo equipment. Use it to locate and solve auto stereo problems and troubles with minimum waste effort. 192 pages.  
No. 20737 .....\$3.95

## 1-2-3-4 SERVING CASSETTES

by Forest H. Belt  
The 1-2-3-4 system makes it a simple matter to trace, pinpoint and correctly service cassette problems. This newest addition to the 1-2-3-4 library is a "must" for service technicians in the fast-growing cassette market. 240 pages.  
No. 20922 .....\$5.25

## AUTO RADIO SERVICING MADE EASY (Second Edition)

by Wayne Lemons  
A clear detailing of auto-radio circuits, from antenna to speaker. Shows how to eliminate noise and interference, determine the correct bias, handle avc trouble. Also covers fm auto radio, multiplex, and stereo tape players. 168 pages.  
No. 20719 .....\$3.95

## CB RADIO SERVICING GUIDE (Second Edition)

by Leo G. Sands  
Complete and practical directions for troubleshooting, servicing, tuning, and testing all types of Citizens Band radio equipment. Includes FCC regulations on equipment performance and maintenance. 160 pages.  
No. 20722 .....\$3.95

## COLOR-TV SERVICING GUIDE

by Robert G. Middleton  
Using full color tube-face illustrations of color-tv trouble symptoms as clues, it details possible causes of the problems, analyzes them, and gives procedures necessary to effect a cure. A quick, effective servicing guide. 112 pages.  
No. 20358 .....\$4.25

## AUTOMOBILE ELECTRONICS SERVICING GUIDE

by Joseph J. Carr  
Auto electronics equipment has come far since the push-button a-m auto radio, and this new guide covers every advance in detail. It explains how to troubleshoot and service a-m and fm car radios, cassettes, and eight-track cartridges. 128 pages.  
No. 20927 .....\$4.95

## SOLID-STATE SERVICING

by William Sloat  
Explains semiconductor theory as it applies to

servicing solid-state electronics, and covers the functions of circuits used in home entertainment electronic products. This format allows development of techniques that apply to all solid-state servicing problems. 160 pages.  
No. 20888 .....\$4.95

## TAPE RECORDER SERVICING GUIDE

by Robert G. Middleton  
Gives full coverage and explanation of servicing techniques and problems encountered in the fast-growing field of tape cartridges, tape cassettes and stereo tape players. Covers both electronic circuitry and mechanical aspects. 96 pages.  
No. 20748 .....\$3.95

## HI-FI STEREO SERVICING GUIDE

by Robert G. Middleton  
Shows how to localize troubles and repair a-m tuners, fm tuners, stereo-multiplex units, and audio amplifiers. Explains use of audio test and measurement equipment to achieve best results. 112 pages.  
No. 20785 .....\$3.95

## RECORD CHANGER SERVICING GUIDE

by Robert G. Middleton  
Fully analyzes the working parts of record changer mechanisms, points up possible defects, adjustments and corrective measures. Many illustrations and exploded views to make the service technician familiar with all working parts. 96 pages.  
No. 20730 .....\$3.95

The Sams Technical Library contains many other helpful books in the electronics servicing field. Send for our free catalog.

 <b>HOWARD W. SAMS &amp; CO., INC.</b> 4300 West 62nd Street, Indianapolis, Indiana 46268		RE 063	
<input type="checkbox"/> 20912	<input type="checkbox"/> 20358	<input type="checkbox"/> 20777	<input type="checkbox"/> 20927
<input type="checkbox"/> 20737	<input type="checkbox"/> 20888	<input type="checkbox"/> 20922	<input type="checkbox"/> 20748
<input type="checkbox"/> 20719	<input type="checkbox"/> 20785	<input type="checkbox"/> 20722	<input type="checkbox"/> 20730

Order from your Electronics Parts Distributor, or mail to Howard W. Sams & Co., Inc.  
Send books checked at right. \$\_\_\_\_\_ enclosed.  
Please include sales tax where applicable.  
 Send FREE 1973 Sams Book Catalog.

Name \_\_\_\_\_ (Please print)  
Address \_\_\_\_\_  
City \_\_\_\_\_ State \_\_\_\_\_ Zip \_\_\_\_\_

Circle 25 on reader service card

**PHONE SENTRY**

*(continued from page 37)*

record the announcement with the tone signal at the end and do not connect up the message recorder No. 2.

You are now ready to put your Phone Sentry to use. Whenever you leave your business or home, switch the control unit on and place the answer player in the **PLAY** mode and the message recorder in the **RECORD** mode. When you return, turn the control unit off, turn on the **PLAYBACK** switch and rewind the message recorder tape. You then can play the messages and return the calls.

The incoming ring signal is rectified by diodes D1 and D2 charging capacitor C2. The present value of C2 (20  $\mu$ f) allows the phone to ring for 2 to 3 seconds. For longer ring periods, increase the value of C2. When this charge reaches 65 volts, after two or three seconds of ringing, the neon bulb conducts, turning Q1 on. RY2 pulls in and is latched on by R4. Positive +6 volts is now supplied to the rest of the circuit, causing RY1 and RY3 to pull in. This connects transformers T1 and T2 to the line and starts the answer player unit No. 1. The output of the answer player is coupled to the telephone lines through

T1 and to the input of tone detector IC1 through capacitor C11.

IC1 contains a phase-locked loop designed for frequency sensing. It has a controlled oscillator, a phase detector, quadrature phase detector and a power output stage. When a signal is applied to input pin 3 of the same phase as the oscillator, the output pin 8 will go low.

When the output of IC1 goes low, the 30-second monostable IC2 is triggered and its output (pin 3) goes high. This turns on relay 4, starting the message recorder unit. After the tone, IC1 goes high, RY3 turns off stopping the answer player. R7 and C4 were chosen to give a 30-second on time for unit No. 2. This time can be changed by changing R7 and/or C4. The caller's message is coupled to message recorder unit No. 2 through T2. At the end of 30 seconds, output pin 3 of IC2 goes low and this negative-going signal is coupled through C3 to Q1, causing Q1 to turn off and release RY2, de-energizing the circuit.

The Phone Sentry control unit has been designed to provide proper coupling to the phone line with no dc voltage on the line and the recorders isolated. The tone signal frequency is below 2400 Hz as required by the phone company. Four "C" cells power the unit. **R-E**

# TV TUNER SERVICE



**PTS ELECTRONICS, INC.**  
is proud to announce the  
**GRAND OPENING**  
of our new Service Center in

# CLEVELAND, OHIO



*now you too...*

*...get Fast 8 hr. Service!*

**\$995**

**1 YEAR GUARANTEE**

**HOME OFFICE—INDIANA**  
PTS ELECTRONICS, INC.  
P. O. BOX 272  
BL OUBINGTON, IND. 47401  
TEL. 812, 826-9331

**PENNSYLVANIA**  
PTS ELECTRONICS, INC.  
P. O. BOX 16856  
PHILADELPHIA, PA. 19142  
TEL. 215, 724-0959

**MASSACHUSETTS**  
PTS ELECTRONICS, INC.  
P. O. BOX 3189  
SPRINGFIELD, MASS. 01103  
TEL. 413, 736-2737

**FLORIDA**  
PTS ELECTRONICS, INC.  
P. O. BOX 6881  
JACKSONVILLE, FLA. 32206  
TEL. 304, 389-9952

**TEXAS**  
PTS ELECTRONICS, INC.  
P. O. BOX 7332  
LONGVIEW, TEX. 75601  
TEL. 214, 753-4334

**SOUTHERN CALIFORNIA**  
PTS ELECTRONICS, INC.  
P. O. BOX 5794  
SAN DIEGO, CALIF. 92109  
TEL. 714, 260-7070

**NORTHERN CALIFORNIA**  
PTS ELECTRONICS, INC.  
P. O. BOX 41354  
SACRAMENTO, CALIF. 95841  
TEL. 916, 482-6220

**COLORADO**  
PTS ELECTRONICS, INC.  
P. O. BOX 4245  
DENVER, COLO. 80204  
TEL. 303, 244-2818

**OHIO**  
PTS ELECTRONICS, INC.  
3682 STATE RD.  
CLEVELAND, OHIO 44134  
TEL. 216, 845-4480

**FREE JOB CARDS**

**FREE SHIPPING LABELS**

Come and see us. PTS Branches are all company owned—No Franchises—we care for our customers. For a **TUNER PART** or **COMPLETE TUNER REBUILT**, come to us, we will take care of your tuner problems like no one else can. **WE'RE PROFESSIONALS—18 years experience made us what we are!**

## You owe it to yourself

to try P.T.S. We are the fastest growing, oldest and now the largest tuner service company in the world. Here is what you get:

1. Fastest Service—8 hour—in and out the same day. Overnight transit to one of our plants.
2. Fine Quality! Your customers are satisfied and you are not bothered with returning tuners for rework!
3. Lower Cost! Up to \$5.50 less than other tuners for rework!
4. Friendly, helpful service! We help you do more business—that way we will do more, too. We want your business and we try to deserve it!

Color—Black & White—Transistor—Tubes  
—Varactor—Detent UHF

VHF or UHF..... \$9.95  
UV-Comb..... \$16.95

Major parts, tubes, transistors, shipping  
charged at net cost  
(Dealer net!)

send faulty unit with tubes, shields and all broken parts to:

**PTS ELECTRONICS, INC.**  
5682 STATE RD.  
CLEVELAND, OHIO 44134  
TEL. 216, 845-4480

or to any of our strategically located Service Centers

for finer, faster,  
**...Precision Tuner Service**



# why pay retail?

Buy from us, save money on

# hifi

Choose from over 100 name brands, and save on time and freight charges by ordering from the location nearest you!

# Midwest Hifi

WHOLESALE & MAIL ORDER DIVISION

Send for our free catalog!  
2455b Wisconsin Ave.,  
Downers Grove, Ill. 60515  
(Attn Ralph Edwards)  
3309 E. J W Carpenter Frwy.,  
Irving, Tex. 75060  
(Attn Ron Elkins)

# Introducing the end to the battered mic.



These two new one-piece swaged-steel-case mics were designed to be abused by the roughest, rockiest performance conditions. Without breaking apart, without losing a dB of sensitivity or a Hz of response. There isn't a mic on the market that can beat them in so many ways.

*Look what you get . . .*

The swaged all-steel cases have unsurpassed ruggedness. No plastic parts to break. Nothing will dent! The non-reflective satin nickel finish prevents on-camera glare, while the smooth-flow styling snugs into the hand naturally, eliminates distractions. Fully shock-mounted, magnetically shielded unitized cartridge elements that are field replaceable. Built-in wind-pop filters. Every mic comes with a snap-on swivel adapter for cradle mounting, and a cable set.

The Model 1656 offers a cardioid polar pattern with 20 dB front-to-back discrimination. As well as the convenience of a lockable On-Off switch. The Model 1655 provides an omnidirectional polar pattern for uniform natural pickup from all directions. Output impedance of 200 ohms balanced integrates with conventional accessories.

University gives you more . . .  
mics that can't be battered.



**UNIVERSITY SOUND**

ALTEC DIVISION OF ALTEC CORPORATION

1515 S. Manchester Ave., Anaheim, California 92803

*Write us about our full line of  
mics and mic stands.*



Circle 28 on reader service card

JUNE 1973 • RADIO-ELECTRONICS 83

# new products

More information on new products is available from the manufacturers of items identified by a Reader Service number. Use the Reader Service Card inside the back cover.

**SUB-MINIATURE LAMPS, T-1 3/4** have all-glass wedge bases for use where space is at a premium.

These 12-V lamps are available in three models: GE-73 has average life of 15,000 hours and light output of approximately 0.3 candlepower; GE-37, 1,500

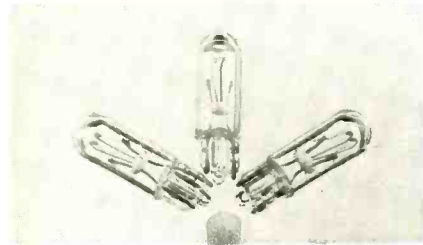

hours and 0.5 candlepower and GE-74, 500 hours and 0.7 candlepower.

Lamp and socket take up less space than other bulbs; push-pull insertion and removal from socket. Less than 1/4" in diameter, 8/10" long, 44¢ each.—**General Electric Co.**, Nela Park, Cleveland, Ohio 44112

Circle 31 on reader service card

**CHRONOMETER KIT, Kronos KR100** series uses LSI National clock chip and 32-page step-by-step illustrated brochure. Includes three setting controls, 1-hour per second, 1-minute per second and hold button. Easy-to-change from 12 to 24 hours, 4 to 6 digits, 50 or 60-Hz



operation. 2" x 6" x 5 1/4".

7-segment MAN-3 type LED's, 6-digit kit, \$47.00; 7-segment MAN-1 type LED's, 6-digit kit, \$69.95; 7-segment Nixie type tube kit, \$47.00.—**Poly Paks Inc.**, P.O. Box 942, South Lynnfield, Mass. 01940

Circle 32 on reader service card

**IC CIRCUIT BOARD D.I.P. 24 Kit** eliminates the need for etching, drilling and making terminals. Boards mount and interconnect dual-in-line packages. Supply lines are positioned adjacent to all DIP locations and connect to outer edge contacts.

Layout pattern permits mounting packages having any number of terminations provided they are 0.1" centers. When boards are in horizontally mounted card frames, the DIP's are positioned in parallel vertical rows.

Consists of a 11824 board that is

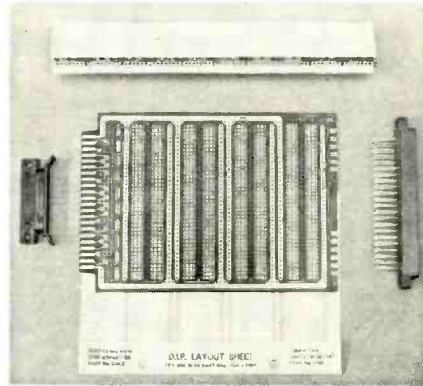

4.5" wide and 6.5" long with 22 contacts on two sides, 0.156 center; 44-pin edge connector; card extraction handle, design sheet and ten 14-pin DIP sockets; \$16.22.—**Vero Electronics Inc.**, 171 Bridge Road, Hauppauge, N.Y. 11787

Circle 33 on reader service card

**VEHICLE BURGLAR ALARM SYSTEM, model SE-812** features the latest sound used by police, fire and emergency vehicles. Has full vehicle protection: sounds



alarm when trunk, door, hood, ignition, lights or brake are activated. Installs in less than 15 minutes; 100% solid state. Protects cars, boats, campers, trailer trucks and buses.

Includes hood and trunk switches and brackets (for cars without hood and trunk lights), electrical switch lock with built-in dust cover and two keys, wire, mounting hardware, instructions, two warning decals and guarantee.—**On-Guard Corporation of America**, 350 Gotham Parkway, Carlstadt, N.J. 07072

Circle 34 on reader service card

**SHOCK-SAFE FUSEHOLDER, 345001** accommodates standard 3AG fuse. Has insulating shield that completely encloses the contacting ring section of the fuseholder side terminal. Electrical continuity is completed by a bayonet-style

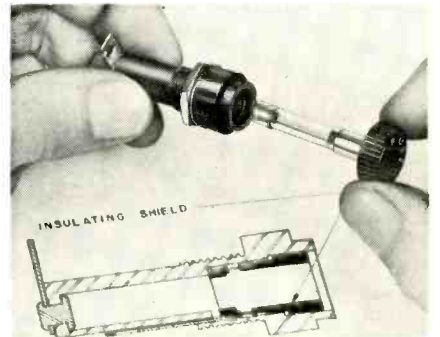

fuse extractor knob. Rated at 20 A for any voltage to 300 volts.—**Littelfuse Inc.**, 800 East Northwest Highway, Des Plaines, Ill. 60016

Circle 35 on reader service card

**FIELD STRENGTH METER, model FSM-4** is portable and solid-state. Includes separate vhf and uhf tuners. Delivers accurate signal-strength readings in dBmV and microvolts from 10µV to 100,000 µV on a large-scale taut-band suspension meter.

Features include audio output jack (earphone provided), gold-plated, accu-



rately calibrated attenuator switches and 75-ohm, type F connector for signal input. Meter is calibrated to read average signal strength. Unit operates on four 9-

volt batteries.

Accuracy in the vhf band is  $\pm 3$  dB while uhf readings are accurate to within  $\pm 4$  dB. 4 lbs., 6 oz.; 9" x 6½" x 4".—**Blonder-Tongue Laboratories, Inc.**, One Jake Brown Road, Old Bridge, N.J.  
*Circle 36 on reader service card*

**MINI TV ANTENNA SYSTEM**, model 5MS440, a new type of TV antenna system intended for metropolitan and suburban reception areas. System consists of a miniature unidirectional antenna, special solid-state amplifier and an electrical rotating mechanism; all enclosed inside



a weatherproof plastic case. Also includes power supply, uhf/vhf band separator, rotator control unit and hardware. Small 18-inch diameter of unit permits installation in many locations not accessible to conventional antennas.—**RCA Parts and Accessories**, Deptford, N. J.  
*Circle 37 on reader service card*

**VHF TV DISTRIBUTION AMPLIFIERS**, series 1000 includes five models that provide compatibility between CATV and MATV requirements. Feature constant match and constant signal-to-noise ratio with changes in gain control ranges having minimal effects on these characteristics. Superior input and output match



assures improved color response and clearer picture quality.

Guaranteed to deliver full rated output for both 7- and 12-channel operation. MATV system performance can be upgraded to CATV specifications.—**Kay-Townes Antenna Company**, P.O. Box 593, Rome, Ga. 30161.  
*Circle 38 on reader service card*

**HEADSET AND DECODER** provides a complete system for 4-channel headset listening. Owner uses present 2-channel stereo equipment and plays 4-channel encoded records or FM. Those who own discrete or matrixed equipment with appropriate phone jacks, can purchase headset separately.

Moving-coil drivers have low-distortion, high-level output at 30 Hz and uniform frequency response up to 16



kHz. Clark/4 CH-A headset is \$80.00 and headset with DC-2A decoder is

\$95.00.—**David Clark Co. Inc.**, 360 Franklin Street, Worcester, Mass. 01604  
*Circle 39 on reader service card*

**SOLID-STATE AMPLIFIER**, Stereo 400 delivers 200 watts rms per channel into an 8-ohm load, 300 watts rms per channel into 4 ohms or 100 watts rms per channel into 16 ohms. It may also be



## Perma-Power Color Brite

### When the picture looks good, you look good.

When a color TV picture fades, or when the black-and-white is erased by a cathode-to-filament short, you can save the day, and the tube, by installing a Perma-Power Britener.

*Boost* models bring out lost sharpness and detail by providing increased filament voltage to increase electron emission. Full contrast and color quality return immediately.

*Isolation* models restore the black-and-white information that gives a color picture its quality, by isolating the short, thus restoring black-and-white video drive.

Short now . . . fade later? Handle

both jobs with a Color-Brite *Combination Isolation and Boost Britener*.

There are Perma-Power Color Brite models for both round tubes and rectangular tubes. In fact, Perma-Power has a Britener for just about every picture tube ever made! You'll look very good to your customer when you prolong the life of the expensive picture tube. Pick up a supply of Color-Brites from your Perma-Power distributor!



PERMA-POWER DIVISION  
 CHAMBERLAIN MANUFACTURING CORPORATION  
 5740 North Tripp, Chicago, Illinois 60646

*Circle 61 on reader service card*



**Model 619 Dynamic \$35.70**

**Model 719 Ceramic \$19.20**

**Ey** These new beauties are tough. No fragile plastics or lightweight metal. Tough baked enamel finish plus heavy chrome plating guarantees lasting good looks.

Just touch the big bar to talk. It latches "on" with a simple, sliding motion. Or move it to the grip-to-talk position on the stand riser in just minutes, with only a screwdriver. DPDT telephone-type leaf switch operates both voice and relay circuits, or electronic switching with the 619 (Hi-Z) and 719.

For top quality, choose Model 619 dynamic with exclusive E-V Acoustalloy® diaphragm. Smooth, peak-free response from 70 to 10,000 cps at -56 dB output insures highest talk power and full modulation. Hi-Z or balanced Lo-Z.

Or choose the economical Model 719 ceramic. Response is from 80 to 7,000 cps at -56 dB output.

Try one of these rugged new beauties today. You'll find that your rig never sounded — or looked — so good!

ELECTRO-VOICE, INC., Dept. 632E  
613 Cecil Street, Buchanan, Michigan 49107

**Electro-Voice®**

a **Gulton**  
COMPANY

\*We cover our bet with a lifetime guarantee. If any 619 or 719 ever fails, just send it to us. We'll repair it at nominal cost. But if there's even a hint that our workmanship or materials weren't up to par, the repair is on the house — even 30 years from now! Fair enough?  
Suggested Resale Net Prices

Circle 62 on reader service card

**FREE** catalog  
over  
**1000**  
unique tools,  
handy kits,  
precision  
instruments,  
technical  
supplies.

Our 20<sup>th</sup> year of service to the World's  
finest craftsmen and technicians.

**National Camera**  
2000 West Union Ave. Dept. G88  
Englewood, Colorado, 80110

Send a FREE copy of the nc Flasher

name

address

city

state

zip

**National Camera**  
2000 West Union Ave. Dept. G88  
Englewood, Colorado, 80110

Circle 63 on reader service card

## ELECTRONIC TECHNICIANS!

Raise your professional standing  
and prepare for promotion! Win  
your diploma in

### ENGINEERING MATHEMATICS

from the Indiana Home  
Study Institute

We are proud to announce two great  
new courses in Engineering Mathematics  
for the electronic industry.

These unusual courses are the result of  
many years of study and thought by the  
President of Indiana Home Study, who  
has personally lectured in the classroom  
to thousands of men, from all walks of  
life, on mathematics, and electrical and  
electronic engineering.

You will have to see the lessons to ap-  
preciate them!

NOW you can master engineering  
mathematics and actually enjoy doing it!  
WE ARE THIS SURE: you sign no  
contracts—you order your lessons on a  
money-back guarantee.

In plain language, if you aren't satis-  
fied you don't pay, and there are no  
strings attached.

Write today for more information and  
your outline of courses.

You have nothing to lose, and every-  
thing to gain!

### The INDIANA HOME STUDY INSTITUTE

Dept. RE-6, P.O. Box 1189, Panama City, Fla. 32401

Circle 64 on reader service card

switched to provide a mono 600-watt  
output into 8 ohms that can directly  
drive a 70.7-volt distribution system.

Features *Dynaguard*, an adjustable  
power limiter that permits full-power ca-  
pability for short-term transient wave  
forms but clamps the sustained output  
above the power level selected on a  
front panel control. Thermal cutout in-  
dicator, heavy-duty power switch and in-  
dividual load protection.—**Dynaco Inc.**,  
3060 Jefferson Street, Philadelphia, Pa.  
19121

Circle 40 on reader service card

**MONITOR RECEIVER**, *Duo-Vox* 2-chan-  
nel vhf FM unit has externally adjustable  
squelch control. Fully transistorized; uses  
mercury or rechargeable Ni-Cad battery;  
low battery drain; 146 to 160 MHz fre-



quency range; built-in antenna plus frac-  
tional microvolt sensitivity for extended  
range. 2-11/15 W x 5-1/2" D; 9-1/2  
oz.—**Unimetrics Inc.**, 23 West Mall, Plain-  
view, N.Y. 11803

Circle 41 on reader service card

**RECORD CLEANER**, *Groovemaster* as  
delicately balanced as a precision  
pickup arm is designed for professional  
as well as amateur use.

As the record spins, a velvet cylin-  
der rides gently over the surface, remov-



ing dust and dirt from recording grooves.  
A nylon brush for applying anti-static  
cleaning fluid to the velvet is also used  
to clean the cylinder. \$11.75.—**Robins In-  
dustries Corp.**, 75 Austin Blvd., Com-  
mack, N.Y. 11725.

Circle 42 on reader service card

**SPEAKER SYSTEM**, *SS-7100* incorpo-  
rates a new means of distortion reduc-  
tion called Ultra Linear Magnetic Circuit.  
It uses hollow pole-pieces that remain

magnetically saturated at all points of the wave form plus a shorting ring of non-magnetic copper whose effect is to neutralize the remaining pole-piece effects.

As a result, third-order harmonic distortion is reduced to as low as 1/5 that



of conventional speakers while higher harmonics (and the second harmonic at high frequencies) are reduced still further. 8" woofer and 1" dome tweeter; \$79.95.—**Sony Corporation of America**, 47-47 Van Dam Street, Long Island City, N.Y. 11101

Circle 43 on reader service card

**SPEAKER SYSTEM, AR-7** offers low distortion, extended and smooth frequency response and wide dispersion. New woofer whose magnetic circuit, voice coil and precisely controlled moving system mass yield optimal use of the acoustic suspension principle was designed specially for this size cabinet.

Both drivers have high temperature voice coils for additional power handling



capability. This system is suited for 4-channel installation.

Impedance is 8 ohms; crossover frequency is 2000 Hz. 8" acoustic suspension woofer, 1 1/2" wide dispersion tweeter. 9 3/4" x 15 3/4" x 6 1/4". \$60.00.—**Acoustic Research Inc.**, 24 Thorndike Street, Cambridge, Mass. 02141.

Circle 44 on reader service card

**DIGITAL MULTIMETER, model 245** a 4 1/2-digit portable unit. Has 21 ranges to



measure dc volts, ac volts, dc current, ac current and resistance with 0.005%

resolution.

Special circuit reduces zero offset, drift and time constant errors. Single LSI/MOS chip.

5 1/2" wide x 1 3/4" high x 3 1/2" deep; 1.3 lbs., \$295.00.—**Data Precision Corp.**, Audubon Road, Wakefield, Mass. 01880.

Circle 45 on reader service card

**GAS WELDING TORCH** is completely self-contained and produces a flame temperature of 5000° F. For welding, brazing or soldering small items made of copper, steel, stainless steel, brass, bronze, aluminum and zinc base alloy as well as rare metals.

Produces high-temperature flame using miniature cylinders of LP gas and Micronox. Needle valves control the flow



of the gases. Size and heat of flame can be adjusted.

Comes complete with torch, flame tips, torch tube, gaskets, gas supply and instructions; \$24.95. Deluxe set includes

## RCA Antenna System Accessories For A Brighter Profit Picture.

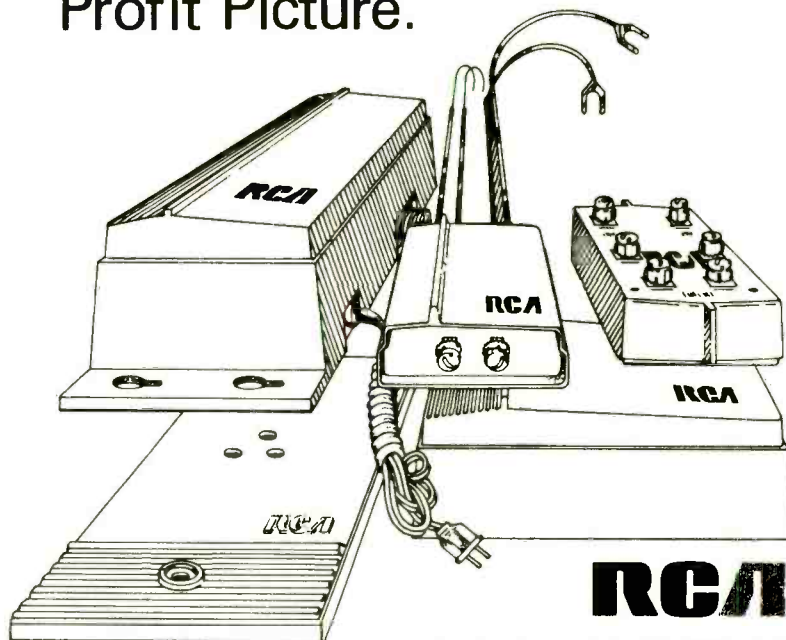

# RCA

Better reception for your customers, more sales for you. From band separators to distribution amplifiers, RCA makes them all. An entire line of easily installed, beautifully compact units, designed to meet rigid performance standards.

For trouble free performance, every device contains RCA solid state circuitry, housed in a contemporary-designed sturdy IMPAC® plastic casing. All amplifiers contain protection against lightning-in-

duced voltage surges. All passive devices are engineered for low insertion loss.

Individually packaged for product protection and consumer appeal, these RCA reception aids are a must for every professional dealer and technician.

For full information on RCA's fast moving profitable line of reception aids, contact your RCA Antenna System Distributor, or mail the coupon below. We'll send you information about our complete line of antenna system accessories.

RCA Parts and Accessories P.O. Box 100 Deptford, N.J. 08096 Dept. L-6

Please send me your RCA Antenna Systems Accessories Catalog.

Name \_\_\_\_\_

Firm \_\_\_\_\_ Phone \_\_\_\_\_

Address \_\_\_\_\_

City \_\_\_\_\_ State \_\_\_\_\_ Zip \_\_\_\_\_

Circle 65 on reader service card

# SPEAKER GUARD

PROTECTS SPEAKER  
AND AMPLIFIER

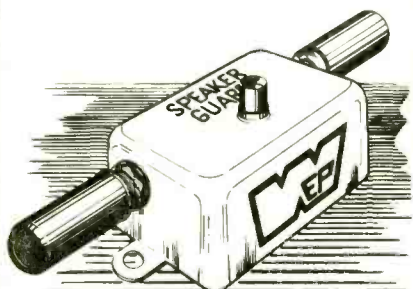

An overload in wattage of amplifier output activates circuit breaker and prevents damage. Reset circuit breaker and make sure you use correct values of Speaker Guard.

18 DIFFERENT VALUES

ASK FOR CAT. # 145C  
**WORKMAN**  
Subsidiary of IPI TECHNOLOGY INC.  
BOX 3928 SARASOTA FLA 33578

*Electronic*  
PRODUCTS, INC.

Circle 66 on reader service card

torch flame tips, bench brackets, flux brazing rods, spark lighter, spare gas cylinders, welding book and instructions; \$34.95.—**Microflame, Inc.**, 3724 Oregon Avenue South, Minneapolis, Minn. 55426.

Circle 46 on reader service card

**TACKY TRAY** has pressure sensitive surface that prevents any small parts from tipping, sliding, rolling or intermingling. Parts stay where put until released with



normal finger-tip grip. Particularly useful for assembly and repair operations, handling minute parts and components.

Consists of six 5½" x 10" peel-off

sheets stacked on sturdy plastic mat. When surface becomes soiled or loses its tack, a handy corner tab facilitates easy removal. Three adhesive tabs on bottom for anchoring to various surfaces.—**Bio-Serv Inc.**, Frenchtown, N.J.

Circle 47 on reader service card

**QUICK PICKS**, No. 9216 offer a quick and easy method of removing transistors or PC type vertical capacitors. Set of seven versatile tools in a convenient plastic carrying case fit more than 25 different outlines of transistors or can



capacitors. Nonmagnetic tools leave hands free to desolder leads and are color coded for size selection. Also make excellent heat sinks. \$9.95.—**GC Electronics**, 400 South Wyman Street, Rockford, Ill. 61101. **R-E**

Circle 48 on reader service card

## INTERNATIONAL Frequency meter FM-2400CH

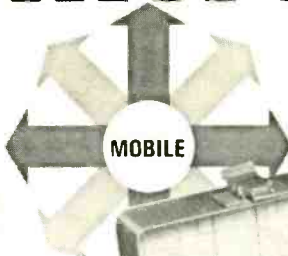

- Tests Predetermined Frequencies 25 to 1000 MHz
- Extended Range Covers 950 MHz Band
- Pin Diode Attenuator for Full Range Coverage as Signal Generator
- Measures FM Deviation

The **FM-2400CH** provides an accurate frequency standard for testing and adjustment of mobile transmitters and receivers at predetermined frequencies.

The **FM-2400CH** with its extended range covers 25 to 1000 MHz. The frequencies can be those of the radio frequency channels of operation and/or the intermediate frequencies of the receiver between 5 MHz and 40 MHz.

Frequency Stability:  $\pm .0005\%$  from  $+50^\circ$  to  $+104^\circ\text{F}$ .

Frequency stability with built-in thermometer and temperature corrected charts:  $\pm .00025\%$  from  $+25^\circ$  to  $+125^\circ$  (.000125% special 450 MHz crystals available).

Self-contained in small portable case. Complete solid state circuitry. Rechargeable batteries.

**WRITE FOR CATALOG!**



FM-2400CH (meter only)	\$595.00
RF crystals (with temperature correction)	24.00 ea.
RF crystals (less temperature correction)	18.00 ea.
IF crystals	catalog price



**CRYSTAL MFG. CO., INC.**  
10 NO. LEE • OKLA. CITY, OKLA. 73102

Circle 67 on reader service card



# new lit

All booklets, catalogs, charts, data sheets and other literature listed here with a Reader Service number are free. Use the Reader Service Card inside the back cover.

**4-CHANNEL SOUND BOOKLET** with 20 questions and 20 answers covers basic definitions and deals with converting stereo systems to 4-channel, matrix vs. discrete sound, rear-channel speaker and power requirements, quadraphonic tape formats, matrix compatibility and enhancement of stereo sound sources.—**BSR-Metrotec**, Blauvelt, N.Y. 10913.  
Circle 49 on reader service card

**ANTENNA CATALOG**, #AC-73. 8-page catalog includes a cross-referenced center fold-out that lists replacement rods for portable AM/FM radios and TV's, walkie-talkie's, indoor FM, uhf, automobiles and scanners. Illustrations of rods and assemblies plus an application chart included.—**Russell Industries, Inc.**, 96 Station Plaza, Lynbrook, N.Y. 11563.  
Circle 50 on reader service card

**SUPER INSTANT-WELD ADHESIVES**. 6-page booklet presents detailed information on four different types of the powerful, quick-setting, permanent bond alpha cyanoacrylate adhesives. 2-page chart of specifications includes setting time, appearance, viscosity, refractive index, and flash point, as well as application data as to best type for use on various materials and combination of materials.—**Oneida Electronic Mfg. Co. Inc.**, P.O. Box 558, Meadville, Pa. 16335.  
Circle 51 on reader service card

**TOOL KIT BROCHURE**. 16-page catalog describes six professional tool kits, each engineer-designed to do a particular job. Included are field engineer kit, electronic technician kit, compact detective kit, electronic lab kit, instrument repair kit, electronic technician roll-pouch kit. Tool kits from \$44.50 to \$555.00. A variety of cases sold separately are also described.—**Jensen Tools and Alloys**, 4117 North 44th Street, Phoenix, Ariz. 85018.  
Circle 52 on reader service card

**DRAFTING TEMPLATES**. 8-page catalog presents line of templates for printed circuit design and drafting. Fourteen templates described and illustrated.—**Tangent Template Inc.**, P.O. Box 20704, San Diego, Calif. 92120.  
Circle 53 on reader service card

**GRANTHAM SCHOOL OF ENGINEERING BULLETIN** describes a degree of Associate in Science in Engineering Technology and a degree of Bachelor of Science in Electronics Engineering. Bulletin includes general information about the program, educational services provided by the school, home-study student services, courses per semester, admission requirements, school policies and G.I. Bill benefits.—**Grantham School of Engineering**, 1505 North Western Ave., Hollywood, Calif. 90027.  
R-E

Circle 54 on reader service card



\*Controlled Quality Crystals for "ON CHANNEL" Communications

FOR  
**CITIZEN BAND**  
23 Channels and "Mars"  
**HAM OPERATORS**  
Commercial 2-Way

**Marine-Monitor**  
See your Distributor for Speedy "Zip Certificates"



**CRYSTEK**

formerly Texas Crystals  
Div. of Whitehall Electronics Corp.  
1000 Crystal Drive 4117 W Jefferson Blvd.  
Fort Myers, Florida 33901 Los Angeles, California 90016  
Circle 68 on reader service card

## ELECTRONIC CALCULATOR THE COMMODORE C-8

A Full Capacity,  
8 Digit Instrument that:  
× MULTIPLIES + ADDS  
÷ DIVIDES — SUBTRACTS

- Full 8-Digit Display
- Constant Factor Memory for Series Multiplication or Division
- Automatic Decimal Function which assures proper placement of the decimal point at all times.
- Large, Easy-to-see Readout
- True Credit Balance with Minus Indicator
- Algebraic Circuitry Logic
- Completely Solid-State—no mechanical parts to cause trouble
- Large, full-size console keyboard for easy, fast operation
- Instant Answers—calculating speed of 0.5 Milliseconds
- U.L. Approved—A/C power cord
- Does Chain Calculations
- Does Complex Mixed Calculations

### THE INSTANT SOLUTION TO—

- Tax Computations • Monthly billing problems
- Expense calculations • Estimating office budgets • Balancing checking accounts • Plus hundreds of applications at home
- Dispense with tedious pencil & paper computations forever.

Here's the Professional Solution to the numbers problem . . . in the office or at home. It's no trick to use This new Commodore Electronic Calculator can do everything an ordinary adding machine can do—plus Multiply, Divide, and Compute Compound Interest! It does it much quicker and quieter too, because it is completely solid-state without all the noisy, mechanical moving parts of the old-fashioned office machines. There's nothing to go wrong—nothing to jam up. If it's plugged in, it's working!

**WARRANTY** . . . Your Commodore C-8 calculator is of such high quality and precision workmanship that it is covered by a 6-month replacement warranty against manufacturer's defects.



Size: 2" x 9" x 6 1/2"

Now \$59.95!

Plus Postage

Please ship me \_\_\_\_\_ Commodore C-8 how many Electronic Calculators at \$59.95 (plus \$2.00 postage and insurance) each.

Illinois residents add 5% Sales Tax.

- Check or Money Order Enclosed  
 Please charge to my credit card  
American Express # \_\_\_\_\_  
Bank Americard # \_\_\_\_\_  
Master Charge # \_\_\_\_\_  
Master Charge Bank # \_\_\_\_\_  
Charge Card Expiration Date: \_\_\_\_\_

NAME \_\_\_\_\_  
ADDRESS \_\_\_\_\_  
CITY \_\_\_\_\_ STATE \_\_\_\_\_ ZIP CODE \_\_\_\_\_

RE-6/73K  
PUT CARD IN ENVELOPE AND MAIL TO:  
**CONTEMPORARY MARKETING, INC.**  
607A COUNTRY CLUB DR.  
BENSENVILLE, ILL. 60106

Catalog & Prices on Request

**FORDHAM** Radio Supply Company, Inc.



558 Morris Ave.  
Bronx, N.Y.  
Tel: (212) 585-0330

RCA

DISTRIBUTORS OF ELECTRONIC SUPPLIES

Circle 69 on reader service card

**The Most Advanced  
Design in Color  
Combo Antennas**



**THE  
ALL-CHANNEL  
C.V.U.**

In these antennas the best features of the log periodic and magnetically driven arrays with an exclusive corner reflector magnetic wave UHF section to make it a top performer. The unique feature of this system is the ability to discriminate between desired signal and unwanted noise. Sharp, vibrant life-like color plus FM stereo listening at its finest.

*Investigate now!*

**S & A ELECTRONICS**

Phone 419-693-0528

202 W. Florence St. Toledo, Ohio 43605

Circle 70 on reader service card

**THE ONE WORD  
FOR PERFORMANCE  
AND RELIABILITY IN  
ELECTRONIC IGNITION**

**JUDSON**

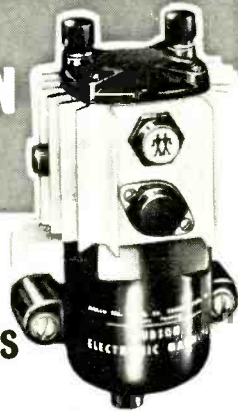

**YOU  
CAN HAVE  
TOMORROW'S  
IGNITION ON  
YOUR CAR TODAY**

Proven by over 100,000 in operation for over five years.

Don't accept "as good as" there are none.

Write Today for Literature

**JUDSON**  
RESEARCH AND MFG. CO.  
CONSHOHOCKEN, PA. 19428



Circle 71 on reader service card

**ELECTRIC HEATERS  
AND SAFETY DEVICES**

by **JACK DARR**  
SERVICE EDITOR

EVEN IN HOMES WITH CENTRAL HEATING, there are a lot of small portable electric heaters around. These are used for special purposes. For example, daughter likes the bathroom very warm, but the rest of the family doesn't want to swelter. These are very common in England; they call them "Electric Fires." Incidentally, these are the only electrical appliances which are almost 100% efficient. There is practically no loss at all. What we want is heat. So we connect a resistance element across the line, and it gets hot. Nothing is wasted.

Heating elements come in a large assortment of sizes and shapes—coiled wire, ribbon, sealed types, and so on. They're all exactly the same, except for the wattage. Just resistance wire, usually an alloy called Nichrome and variations; nickel and chromium. The wattage of a heating element depends on its resistance. The lower the resistance, the higher the current and the more heat.

As far as diagnosis of electrical faults is concerned, they're really pretty elementary. They're either good or open. (Or since they're electrical, they can be intermittent!) There are only a few things to go bad; line cord, switch or heating element. Easy to check out with an ohmmeter or a simple neon trouble lamp.

Most of the troubles will be in the things like broken line cords, open heating elements or dirty switches. Due to the high currents, a dirty switch contact or loose connection will cause trouble. They will arc, and this can cause heavy interference in nearby TV and radio sets. If they are allowed to arc for too long a time, the contact will burn open.

Loose connections to the ends of the heating elements cause a lot of problems. These are usually made with a long bolt. It goes through a hole in the metal frame, with ceramic insulators. On the top side, the end of the heating element is fastened between two flat washers, held by a nut. Below the insulators, the line cord is fastened in the same way, between

**Pix-Mate™**  
**the CRT tester**

**you can afford to take along**

**only ... \$34.95**

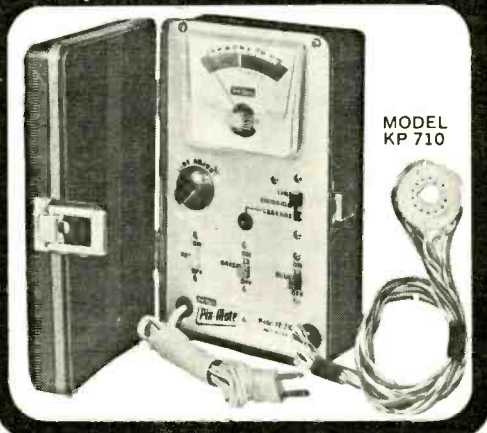

MODEL  
KP 710

A quality CRT tester with individual test for each gun.

- Compare guns for emission.
- Test for leakage and shorts.
- Legible 3 color scale.
- Compact, portable, rugged.
- Avoid recalls, check the CRT on every call.

WRITE US!

**TeleMatic**

**take along the time savers**

• PIX-MATE • CRY-S-MATE • GEN-MATE  
• SOUND-MATE • TRACE-MATE

**The Caddy-Mate Line.**

2245 PITKIN AVE., BROOKLYN, N. Y. 11207

Circle 72 on reader service card

# appliance clinic

two flat washers, held by two nuts. If either of these works loose, or wasn't properly tightened to start with, the connection will arc. This can actually weld the nuts to the threads, so that you can't move them, either to take them off or tighten them.

I ran into one of these not too long ago. I could get the line-cord connector off, but the other end had been arcing too long. The nut was firmly welded to the threads and the element was very loose. (The idea is to get the end of the element loose without breaking it.) In the end, I managed to unwind a couple of turns of the flat ribbon element, and get enough of it out of the cabinet to clamp the bolt in a vise. Then, I sawed the head of the bolt off. The space was so small that I had to use a special razorblade saw, with a very thin blade, (which is a part of an X-Acto-Knife set; in radio-TV and hobby stores).

The better grade of heaters have safety devices. Many have thermostats which can be adjusted for any amount of heat desired. Others have special switches, for HIGH, MEDIUM or LOW heats; these switch the heating elements into various combinations. For example, one that I know of has two 1-kW elements. For low heat, one element is turned on. For medium heat, both are connected in series across the 120-volt line. For high heat, both are connected in parallel.

Safety devices are also used. If one of these heaters was sitting on a carpeted or plastic covered floor, and tipped over face down, it could set the floor on fire. So, a device called a "tip-switch" is used. Most of these are pretty simple. On one make, it's just a little rod sticking through the bottom of the case. The top of the rod holds a spring switch closed, as long as the case is upright. If it falls over the spring loaded rod moves down and the switch opens.

This can cause problems while you're working on one if you don't know they use a tip-switch. You may replace an element, and then try to get it to heat up while lying on its back on the bench. If it won't work, check to see if it has a tip-switch.

Replacement heating elements can be purchased at any electrical supply store or hardware store. Be sure to

check the wattage rating of the original, and get one exactly like it. This rating should be on the rating plate on the back of the case, near the point where the line-cord goes in. If necessary, you can use a different type of element; a flat ribbon in place of a coiled wire, or vice versa. Just be sure that you mount the element tightly on the ceramic insulators.

When replacing line cords, check the wattage rating. You must use a cord which has wire big enough to carry the current without getting hot itself. For the smaller types, No. 14 wire is good, but for the bigger ones you'd better use either No. 12 or No. 10 stranded wire. Older ones used to use the heater-cord type, which was asbestos insulated, with a heavy braided jacket. Newer models use a plastic insulated cord, like the zipcord on TV line-cords, but much bigger. The important thing is wire size. **R-E**

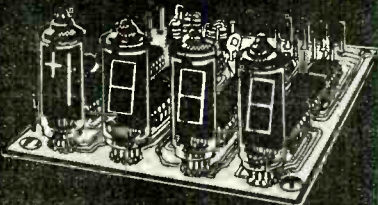
**Multipurpose Digital Panel Meter Kit**

- \* VOLTMETER
- \* COUNTER
- \* TIMER

**\$57<sup>50</sup>**

The State-of-the-Art in electronic kits. The DM-10 is a complete digital voltmeter in a miniature package. It has built-in provisions for conversion to resistance, current, frequency, and elapsed time meters. We supply a 20 page booklet with all these applications and more. Input/output connections TTL compatible.

We accept orders on MASTERCARD and BANKAMERICARD. Include all RAISED information from your card.

**epd ELECTRONICS**  
BOX 1014 Glenwood Springs, CO 81601

Circle 73 on reader service card

# SPRING SALE

## RAYTHEON

<input type="checkbox"/> 5-3HQ5 .....	\$6.20	<input type="checkbox"/> 5-6BA11 .....	\$5.35
<input type="checkbox"/> 5-6AW8 .....	\$4.90	<input type="checkbox"/> 5-6KT8 .....	\$5.90
<input type="checkbox"/> 5-6GU7 .....	\$4.65	<input type="checkbox"/> 5-6GH8 .....	\$3.45
<input type="checkbox"/> 5-6HA5 .....	\$4.20	<input type="checkbox"/> 5-12AU7 .....	\$3.30
<input type="checkbox"/> 5-6JC6 .....	\$4.90	<input type="checkbox"/> 5-8FQ7 .....	\$3.25

<input type="checkbox"/> Circuit Breakers 1.25 Amp. ....	10 for \$1.00
<input type="checkbox"/> 10 Asst'd Aligning Tools .....	\$1.98
<input type="checkbox"/> 100 Asst'd Mica Cond. ....	\$1.19
<input type="checkbox"/> 300 Asst'd 1 & 2 Watt Res. ....	\$4.95
<input type="checkbox"/> HV Anode Leads B/W Sets .....	10 for \$1.00
<input type="checkbox"/> RF Cables Tinned Ends .....	6 for \$.89
<input type="checkbox"/> DELAY LINES .....	2 for \$1.19
<input type="checkbox"/> Knife Switches DPDT .....	4 for \$1.00
<input type="checkbox"/> Spaghetti Asst'd .....	.75 Pcs. \$.59

## DIODES SEMI CONDUCTORS

<input type="checkbox"/> HEP 170 2.5 Amp. ....	25 for \$4.95
<input type="checkbox"/> 1000 PIV .....	4 for \$2.00
<input type="checkbox"/> 6500 PIV Focus Rect. ....	5 for \$3.00
<input type="checkbox"/> 13.5 KV Focus Rect. ....	3 for \$2.49
<input type="checkbox"/> 18.5 KV Focus Rect. ....	5 for \$2.00
<input type="checkbox"/> Sel. Boost Rect. ....	25 for \$2.00
<input type="checkbox"/> Crystal Diodes 1N34A .....	

## CONDENSERS—(CANS)

<input type="checkbox"/> 300 Mfd.—200 Volts .....	4 for \$2.00
<input type="checkbox"/> 500 Mfd.—200 Volts .....	3 for \$2.00
<input type="checkbox"/> 160-100-60 Mfd.—350 V. ....	6 for \$2.49
<input type="checkbox"/> 500 Mfd.—50 Volts .....	3 for \$1.49
<input type="checkbox"/> 1500 Mfd.—50 Volts .....	3 for \$1.98
<input type="checkbox"/> 25 Assorted Cans .....	\$4.95

## CONDENSERS (AXIAL LEADS)

<input type="checkbox"/> 100 Mfd.—150 Volts .....	12 for \$1.98
<input type="checkbox"/> 50 Mfd.—25 Volts .....	5 for \$1.00
<input type="checkbox"/> 16 Mfd.—450 Volts .....	4 for \$1.19
<input type="checkbox"/> 500 Mfd.—75 Volts .....	3 for \$1.49
<input type="checkbox"/> 1000 Mfd.—50 Volts .....	6 for \$2.49
<input type="checkbox"/> .01 Mfd.—1KV (Spark Gap) .....	20 for \$2.00
<input type="checkbox"/> 25 Asst'd Disc Cond. ....	\$1.39
<input type="checkbox"/> 25 Asst'd Cond Axial .....	\$4.95

## SPEAKERS

<input type="checkbox"/> 3" Round .....	\$ .49	<input type="checkbox"/> 6" Round .....	\$1.39
<input type="checkbox"/> 3 1/2" Sq. ....	\$ .69	<input type="checkbox"/> 5X7 .....	\$1.99
<input type="checkbox"/> 4" Sq. ....	\$ .79	<input type="checkbox"/> 6X9 .....	\$2.59
<input type="checkbox"/> 2X6 .....	\$ .99	<input type="checkbox"/> 4X10 .....	\$2.79
<input type="checkbox"/> 4X6 .....	\$ .99		

MINIMUM ORDER \$15.00

SEND FOR FREE CATALOG

TUBES UP TO 80% OFF

SEND CHECK OR

MONEY ORDER

TV TECH SPECIALS

P.O. BOX 603

Kings Park, L.I.,

New York 11754

Circle 74 on reader service card

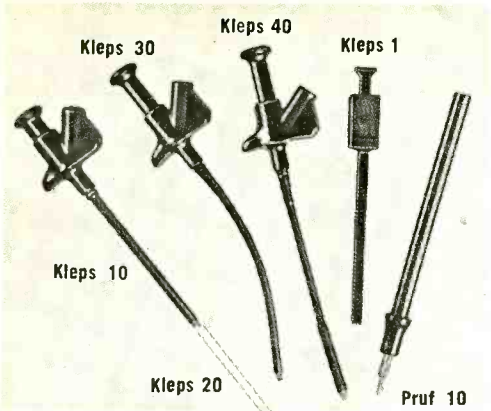

## Clever Kleps

Test probes designed by your needs—Push to seize, push to release (all Kleps spring loaded).

**Kleps 10.** Boathook clamp grips wires, lugs, terminals. Accepts banana plug or bare wire lead. 4¾" long. \$1.19

**Kleps 20.** Same, but 7" long. \$1.39

**Kleps 30.** Completely flexible. Forked-tongue gripper. Accepts banana plug or bare lead. 6" long. \$1.47

**Kleps 40.** Completely flexible. 3-segment automatic collet firmly grips wire ends, PC-board terminals, connector pins. Accepts banana plug or plain wire. 6¼" long. \$2.39

**Kleps 1.** Economy Kleps for light line work (not lab quality). Meshing claws. 4½" long. \$ .99

**Prof 10.** Versatile test prod. Solder connection. Molded phenolic. Doubles as scribing tool. "Bunch" pin fits banana jack. Phone tip. 5½" long. \$ .79

All in red or black - specify. (Add 50¢ postage and handling). Write for complete catalog of - test probes, plugs, sockets, connectors, earphones, headsets, miniature components.

Available through your local distributor, or write to:



**RYE INDUSTRIES INC.**  
127 Spencer Place, Mamaroneck, N.Y. 10543  
In Canada: Rye Industries (Canada) Ltd.

Circle 75 on reader service card

## AT LAST! PROFESSIONAL HOME PROTECTION EVERYONE CAN INSTALL AND AFFORD.

Model FC-100  
**\$69.95**  
WIRED



- Start your custom Burglar/Hold-up/Fire Alarm System with the FC-100. Add on Sensors, Alarms and Accessories to suit your own needs.
- "Do-it-Yourself" Installers Handbook included. No technical knowledge needed — No soldering.
- 100% Professional in Design, Reliability, Performance.



**'Fail Safe'-SYSTEM BY EICO**

A New Concept in "Do-it-Yourself" Home Protection

### FREE 32 PAGE EICO CATALOG

For latest catalog on EICO Test Instruments, Stereo, EICOCRAFT Projects, Environmental Lighting, Burglar/Fire Alarm Systems, and name of nearest EICO Distributor, check Reader Service Card or send 25¢ for First Class mail service.

EICO, 283 Malta Street, Brooklyn, N.Y. 11207



Circle 76 on reader service card

# next month

JULY 1973

- **Build A Modulated IC Function Generator**  
This unit delivers six different waveforms—sine, triangle, square, sawtooth, ramp and pulse with both AM and FM modulation over a frequency range of 1 Hz to 1.5 MHz. It's built around two Exar IC's.
  - **How To Test Hi-Fi Amplifiers**  
Equipment setups and procedures for measuring power output, distortion, power bandwidth, sensitivity, damping factor, signal-to-noise-ratio and frequency response of any hi-fi amplifier.
  - **Inside A Modern Calculator Kit**  
See what it's like to build the MITS 1440 desk calculator. You'll also get a look at the electronics that make it work.
  - **Amplifier Strapping**  
Leonard Feldman, R-E's new Contributing High-Fidelity Editor, shows what happens when a 4-channel amplifier is switched to 2-channel playback. It sounds simple, but is actually quite complex.
- PLUS**  
Step-By-Step Troubleshooting  
Lou Garner's State-Of-Solid-State  
Boolean Algebra Made Easy  
Jack Darr's Service Clinic  
R-E's Transistor Substitution Guide

# books

**MONOCHROME GENERAL ELECTRIC TV SERVICE MANUAL (TAB Book No. 558), MONOCHROME MOTOROLA TV SERVICE MANUAL (TAB Book No. 594),** by Harvey F. Swearer. **GENERAL ELECTRIC COLOR TV SERVICE MANUAL, Volume 2 (TAB Book No. 609),** by Stan Prentiss. TAB Books, Blue Ridge Summit, PA 17214. 8½ x 11 in. 160 pps, 196 pps and 212 pps, respectively. \$7.95 (each title) in vinyl leatherette cover, \$4.95 paperbound.

These are three of the latest additions to a series of TV service manuals that need no introduction to Radio-Electronics readers. Each manual is a comprehensive compilation of pertinent service information on the latest TV receiver models of a particular make. Included are detailed analysis of circuit functions and operation, along with all necessary schematics, photographs, waveforms, alignment tables and troubleshooting information to enable the technician to troubleshoot and service the subject receivers. The theoretical presentation, alone, is well worth the cost of the manual.—RFS

**THE SEMICONDUCTOR DATA LIBRARY, 1st Edition.** By Technical Information Center, Motorola, Inc., P.O. Box 20924, Phoenix, Ariz. 85306. 3-volume set, 7 x 9¼ in., more than 3200 pp. Leatherette covers. \$6.50 for basic set, \$10.00 for set and updating service covering 18 months and consisting of two supplements to Volume II and three quarterly brochures and two completely revised editions of The Reference Volume.

The Semiconductor Library presents Motorola discrete semiconductors in three volumes, organized as follows:

**Volume I**—Complete data sheets for Motorola devices bearing EIA numbers to 1N4999 and 2N4999. **Volume II**—Complete data on EIA numbers 1N5000 and 2N5000 and higher as well as 3N . . . types and those bearing special Motorola type numbers. **Volume III** will be updated by two supplements during its life.

**Reference Volume**—A compendium of semiconductor devices and IC information prepared to enable the reader to locate and select devices for almost any application or circuit. Separate indexes cover EIA-registered devices, non-registered Motorola types, microcircuit components, groupings of devices by categories and applications and Military specifications. Dimensional outlines and packaging and hardware information are supplied. This volume will be completely updated twice a year; with supplementary publications quarterly.

**NORTH AMERICAN RADIO-TV STATION GUIDE, 8th Edition,** by Vane A. Jones. Howard W. Sams Co., 4300 W. 62nd St., Indianapolis, Ind. 46268. 5½ x 8½ in., 160 pp. Soft cover \$3.95 (\$4.95 in Canada).

White's Radio Log it isn't, but it is the nearest thing to it. This new and up-to-date guide contains listings for all radio and TV stations in the U.S., Canada, Mexico and The West Indies.

The over 5500 AM stations, over 3000 FM stations and nearly 1200 TV stations in operation, scheduled to start soon or temporarily off the air are listed three ways—by call letters, frequency or channel and geographical location. Other pertinent information includes network affiliation; power (day and night), height of antennas, and whether or not an FM station broadcasts in stereo. A must for the broadcast and TV DX'er and tourist in the countries covered.—RFS

**MECL SYSTEM DESIGN HANDBOOK.** Compiled by Wm. R. Blood, Jr., et al, Computer Applications Engineering Dept., Motorola, Inc., P.O. Box 20924, Phoenix, Ariz. 85036. 7 x 9¼ in. 214 pp. Soft cover, \$2.00.

The Handbook presents complete up-to-date information on MECL devices. (MECL is a Motorola trademark used to identify its emitter-coupled logic devices.) It gives the designer the information needed to establish design rules for his own high-performance systems. Included are rules and guidelines for working with the MECL II, MECL III and new low-power MECL 10,000 series logic devices and for interfacing the various other logic systems with MECL.

**UNDERSTANDING OSCILLATORS** by Irving M. Gottlieb. Howard W. Sams & Co., Indianapolis, Ind. 46268. 8 5/16 x 5 3/16 in. 160 pp. Soft cover, \$4.50.

Here is the book on fundamentals of oscillators you have been looking for—how they work, their personalities, their strong and weak points, and how they are used in practical applications. A number of circuits, with their various active devices, will be seen to derive their operations in a more or less similar manner. Emphasis in the text has been directed toward the application of semiconductors to oscillators, even though the tube circuit retains its place as the basic oscillator throughout the exposition.—MCL

R-E

# MOVE AHEAD from Technician to ENGINEER

## Advance beyond the technician level Become an electronics engineer

Your technical experience can be a valuable asset in advancing your electronics career to the *engineering* level. By adding engineering training and a college degree to your experience, you can *move up* to greater opportunities.

After three years of reduced demand, electronics engineering is now beginning to BOOM! It is predicted that there will be twice as many engineering jobs available by 1976 as there will be graduates to fill them.

Grantham School of Engineering is a college-level institution, specializing in teaching electronics, computer science, and supporting subjects, mainly

### BY CORRESPONDENCE

You may earn your A.S.E.T. degree by correspondence, and then earn your B.S.E.E. degree thru additional training in residence.



## Grantham School of Engineering

1505 N. Western Ave.

Hollywood, Calif. 90027

Mail the coupon below for our free Bulletin

### Grantham School of Engineering

RE-673

1505 N. Western Ave., Hollywood, Calif. 90027

Please mail me your free Bulletin, which explains how the Grantham educational program can prepare me for my Degree in Electronics Engineering.

Name \_\_\_\_\_

Address \_\_\_\_\_

City \_\_\_\_\_ State \_\_\_\_\_ Zip \_\_\_\_\_

I have been in electronics for \_\_\_\_\_ years.

Circle 77 on reader service card

JUNE 1973 • RADIO-ELECTRONICS 93

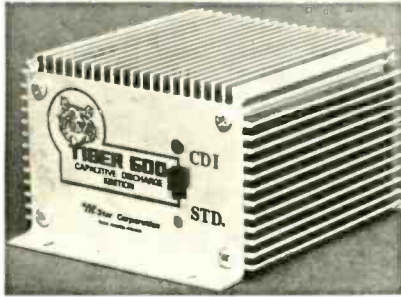

## 12 REASONS YOUR CAR NEEDS A TIGER 500

Instant starting in any weather - Eliminates tune-ups - Increases gas mileage - Increases horsepower 15% - Improves acceleration & performance - Spark plugs and points last up to 70,000 miles - Reduces engine maintenance expense - Amplifies spark plug voltage to 45,000 volts - Maintains spark plug voltage to 10,000 RPM - Reduces exhaust emissions - Dual ignition switch - Unconditional guarantee for original owner - Installs in 10 minutes on any car with 12 volt negative ground - No rewiring - Most powerful, efficient and reliable Solid State Ignition made.

SATISFACTION GUARANTEED  
or money back.

Assembled ..... \$49.95  
Post Paid In U.S.A.

Send check or money order with order to:

**Tri-Star Corporation**

Dept. R, P. O. Box 1946  
Grand Junction, Colorado 81501  
DEALER INQUIRIES INVITED

Circle 78 on reader service card

## hearing through the teeth

Not so long ago, Dr. Earl Collard of the University of California was playing with a tuning fork. Accidentally placing it against one of his teeth just after it had ceased sounding, he was surprised to hear a clear, easily audible tone. The tuning fork was still vibrating, and the sound—not loud enough to be heard by ear—came through “loud and clear” by tooth conduction.

Professor Collard decided that the new principle—hearing through the teeth—might become “the basis of an entirely new method of communication,” and named it *Audionetics*.

The idea is not quite as new as Dr. Collard thinks. Hugo Gernsback patented, in December 1924, a device for hearing through the teeth. It consisted of a vibrating electromagnet with two rubber bit pieces to be held between the teeth of the user. It was intended to be connected to the output of a radio, or to be used with a microphone and amplifier, as an aid to the partially deaf. Gernsback called it the *Osophone* (*os*-bone, *phono*-voice).

Incidentally, this was the first bone-conduction hearing aid. Later, in 1934, Gernsback worked out a similar device, to be applied to the forehead.

But the original Gernsback de-

vices both got their signals from an audio amplifier and both depended on large and rather clumsy devices to get the sound to the listener's bone channels. Dr. Collard has added a new idea. His transducer is a tiny radio receiver, placed *inside* the listener's mouth. It may be mounted in bridge-work, in a gap left by a missing tooth,



or even inserted as a filling in a tooth itself. A tiny transceiver (or more correctly, translator) carried in a pocket or suspended in clothing would pick up radio signals from a given source (a wireless microphone for example) and retransmit them to the tooth receiver. It in turn would send them through the bones of the jaw and into the inner ear. **R-E**

## Spots trouble fast-tells where it is



WR-515A Master Chro-Bar/  
Signalyst is the most advanced  
color-bar generator ever  
developed by RCA

Consider these features:

- Output at RF, IF, and Video for all patterns.
- RCA's exclusive "Superpulse" pattern for simplified gray-scale tracking adjustment, testing for picture smear, and trouble-shooting by signal tracing and signal injection.
- RCA's exclusive color-bar marker identifies the third, sixth, and ninth color bars . . . aids in AFPC alignment and setting the tint control range.
- Pushbuttons provide color bars, dots, lines, crosshatch, and blank raster patterns with provision for selecting three or ten horizontal and/or vertical lines with middle of pattern electrically centered.

- 75-ohm or 300-ohm variable level RF, IF, and Video output with positive or negative video sync. polarity.
  - IC circuitry throughout.
- The price? Only \$189.00!\*

For more information on the WR-515A, see your RCA Distributor or write RCA Electronic Instruments Headquarters, Harrison, N.J. 07029.

\*Optional Distributor Resale Price

**RCA** Electronic  
Instruments

Circle 79 on reader service card

# SIZZLING VALUES

FREE \$1 BUY WITH EVERY 10 YOU ORDER Only applies to "S1" Buys FREE GIFT WITH EVERY ORDER

## SHANNON MYLAR RECORDING TAPE

2 1/2" - 225' .. \$ .17	7" - 2400' ..... \$1.79
3" - 225' .. .19	7" - 3600' ..... 2.95
3" - 300' .. .27	CASSETTE C-60 ..... .59
3 1/4" - 600' .. .58	CASSETTE C-90 ..... 1.00
5" - 600' .. .62	CASSETTE C-120 (TDK) 1.97
5" - 900' .. .80	2 1/2" TAPE REEL .... .05
5" - 1200' .. .97	3" TAPE REEL .... .06
5" - 1800' .. 1.49	3 1/4" TAPE REEL .... .07
7" - 1200' .. .77	5" TAPE REEL .... .14
7" - 1800' .. 1.12	7" TAPE REEL .... .15

CANADIANS: Ordering is easy - we do the paperwork - try a small order

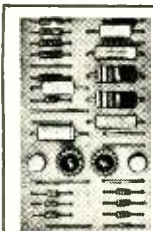

**IBM COMPUTER SECTIONS**  
8 assorted Units we sell for \$1 are loaded with over 150 valuable parts.  
Incl. - Transistors, Condensers, Resistors, Heat Sinks, Diodes, Etc.  
**8 for \$1**  
**100 for \$10**

## WESTINGHOUSE ALL TRANSISTOR HOME/OFFICE MESSAGE CENTER

Leaves messages for other for replay... Built in speaker/microphone for talk-into convenience... Records up to 3 minutes of messages... Illuminated signal shows when a message is waiting. Control adjusts playback volume without affecting recording volume... Capstan Drive:  
**BRAND NEW SOLD AS IS \$7.95**

## RCA 110° FLYBACK TRANSFORMER

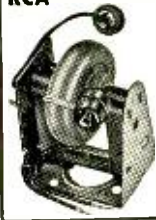

We scooped the Market Latest type - standard for all 110° TV's  
RCA's design of large Coil produces 18KV assuring adequate width Incl Schematic Diagram application for any TV  
List price \$13.90  
Your price .. \$3  
10% off in lots of 3

- 110° TV DEFLECTION YOKE for all types TV's incl schematic \$3.95
- "COMBINATION SPECIAL" RCA 110° FLYBACK plus 110° DEFLECTION YOKE \$5.95
- 80° FLYBACK TRANSFORMER for all types TV's incl schematic \$2.95
- 90° TV DEFLECTION YOKE for all types TV's incl schematic \$2.95
- 70° FLYBACK TRANSFORMER for all type TV's incl schematic \$2
- 70° TV DEFLECTION YOKE for all type TV's incl schematic \$2
- SHARP 110° FLYBACK & YOKE COMBINATION #8FT-592 Good for most portable TV \$5.00
- 90° COLOR YOKE For all Rectangu- lar 19 to 25" color CRT's \$10.95
- RCA COLOR FLYBACK Part #113882 (Stancor # H0-601C) \$12.95
- UTAH "CELESTA" 3-WAY CO-AX SPEAKERS 8"-10 oz. Mag.-30 Watta. \$16.95
- UTAH "CELESTA" 3-WAY CO-AX SPEAKERS 12"-20 oz. Mag.-45 Watta. \$24.95
- UHF TUNER-TRANSISTOR TYPE Used in all TV sets \$3.95
- STANDARD TUNER-TRANSISTOR GUIDED GRID 4 Channel closed circuit \$1
- PHILCO TV TUNERS Model-76-13983-3 (6GJ7-3H5) \$4.95
- MAGNAVOX TV TUNER 340187-3 (6C08-6C05 tubes) \$7.95
- GE-STANDARD COIL TV TUNER Model EU-56X1 (6H95-6GJ7) Model-ET 86X304-(6L28-6HA5) \$7.95
- TV TUNERS VHF/UHF all new standard makes, including Tubes \$7.95

- 150 - ASST. 8/32 SCREWS and 150- 8/32 HEX NUTS \$1
- 150 - ASST. 2/56 SCREWS and 150- 2/56 HEX NUTS \$1
- 150 - ASST. 4/40 SCREWS and 150- 4/40 HEX NUTS \$1
- 150 - ASST. 5/40 SCREWS and 150- 5/40 HEX NUTS \$1
- 500 - ASSORTED RIVETS most useful selected sizes \$1
- 300 ASSORTED WASHERS most useful selected sizes \$1
- 100 - ASST. RUBBER BUMPERS for cabinet bottoms - other uses \$1
- 100-ASSORTED RUBBER GROMMETS best sizes \$1
- SIMPSON 2 1/2" ROUND PANEL METERS Model 125 (0-10 DC Milliammeters \$3.95
- 12" UNIVERSAL SPEAKER Top Quality Large Magnet \$4.89
- 10" PHILCO SPEAKER Top Quality Large Magnet \$2.99
- 8" UNIVERSAL SPEAKER - Large Magnet-Special Buy \$2.99
- 5" UNIVERSAL TWEETER 1 Oz. Magnet \$1.29
- UNIVERSAL 4" PM SPEAKER Top Quality \$1
- 2 1/2" x 4" SPEAKER Special Buy 10 for \$6 \$69 C Ea.
- 4" X 6" "QUAM" 16 OHM SPEAKER Large magnet. Special BUY (10 for \$17.99 \$15.99)
- RONETTE STEREO CARTRIDGE latest dual sapphire flipover type \$2
- STEREO HEADPHONES Hi-Fi Quality \$5.95
- Complete with Stereo plug \$5.95
- COLOR POWER TRANSFORMER - Good for most sets 26R150 List Price-\$36.75 \$6
- 4-50" HANKS HOOK-UP WIRE assorted colors \$1
- 100'-SPOOL SPEAKER WIRE 2 cond. mini slip, clear, 101 uses \$1.50
- 8" ASST. RADIO & TV TUBES Every Tube good number \$1
- 5 - AUDIO OUTPUT TRANSFORM Sub-min for Trans Radios \$1
- 5 - I.F. COIL TRANSFORMERS 456-kc for Transistor Radios \$1
- 8" UNIVERSAL SPEAKER Top quality \$2.29
- Special Buy Ea. \$5 for 10
- ALL AMERICAN TUBE KIT (12A V6-12BE-12B A6-35W4-60C6) \$2.99
- 70" COLOR TUBE \$3.95
- 90" COLOR TUBE \$4.95
- 100-ASSORTED DIODE CRYSTALS 1N34, 1N48, 1N60, 1N64, etc \$1
- 6 - TOP BRAND SILICON RECTIFIERS 1 amp. 1000 PIV \$1
- 5 - PNP TRANSISTOR general purpose, TO-5 case \$1
- 5 - NPN TRANSISTORS general purpose, TO-5 case \$1
- 50 - ASSORTED TRANSISTORS big factory scoop-sold as-is \$1
- TV TWIN LEAD-IN 300 ohm 500' - \$7 100's \$1.50 50' \$1
- 12-MINIATURE ELECTROLYTIC CONDENSERS For Transistor & miniature work \$1
- CLARICON AM FM TUNER Solid state, walnut cabinet \$59.95
- WEN SOLDER GUNS Model 225K.....\$8.50 Model 288.....\$7.50 Model 25D.....\$9.95 Model 100K.....\$5.95
- 8 ELEMENT COLOR OUTDOOR AN- TENNA Big shot Jr. List \$11.95 \$5.95
- ARISTO WIRELESS INTERCOM 6- TRANSISTOR 6H-1000 Solid state, plug in AC, each unit a "MASTER" \$14.95
- ARISTO WIRELESS INTERCOM Walnut Cabinet, with buzzer call, AC op-eration \$22.50

## MARKET SCOOP COLUMN

- KLEPS "CLEVER" TEST PRODS "Third-hand" test prods, reach into out of way places - Insulated - cannot slip - accommodates bare wire or banana plug-no soldering.
- PRUF 10 - VERSATILE TEST PROBE \$1.19
- KLEPS 10 - BOATHOOK CLAMP 4 1/4" long \$1.39
- KLEPS 20 - BOATHOOK CLAMP 7" long \$1.47
- KLEPS 30 - FLEXIBLE-FORKED TONGUE 6" long \$2.39
- KLEPS 40 - FLEXIBLE-PC BOARD TERMINAL 6 1/4" long \$1
- KLEPS 1-ECONOMY KLEPS-FOR LIGHT WORK .99
- ASTATIC PICKUP MODEL 700-89T Contains 89T ceramic cartridge LIST PRICE \$17.00 \$2.95
- 20 - DIPPED MYLAR CAPACITORS .01-1 600V \$1
- 20 - DIPPED MYLAR CAPACITORS .033-1 600V \$1
- 20 - DIPPED MYLAR CAPACITORS .0033-1 1000 V \$1
- 20 DIPPED MYLAR CAPACITORS .047-400 V \$1
- 15 - MOLDED TUBULAR CAPACITORS .008-400 V \$1
- 20 - DIPPED MYLAR CONDENSERS .033-400V \$1
- 10 - SPRAGUE "ORANGE DROP" CAPACITORS 0056-2000 VOLT \$2.95
- 1 - 20 FT. COILED GUITAR CABLE With plugs \$2.49
- 1 - CASSETTE TYPE DYNAMIC MICRO-PHNE with universal plugs-200 Ohms. \$2.89
- 2 - COLORBURST QUARTZ-CRYSTAL For Most Color TV sets 3579.545 KC \$1
- 4-ELECTROLYTIC CONDENSERS 75/30mfd-150V \$2.29
- 6" x 1 1/2" INVERTED CONE" SPEAKER Top quality Thinline \$3.95
- 1-8" x 9" HEAVY DUTY 10 OZ. SPEAKER Ceramic Type .8 Ohm \$3.95
- 5 ASSTD. GLOBAL VARISTOR Popular replacements for most COLOR TV \$1
- 10 - SETS PHONO PLUGS & PIN JACKS RCA type \$1
- 8-PRINTED CIRCUIT IF TRANSFORMERS 4-Lug, 456 KC \$1
- STEREO TONE ARMS Most popular type-turn over cartridge \$2
- CO-AX CABLE RG59U grey or black 250'-\$9 100'-\$8.50 50'- \$7 \$2
- 4 - TV ALIGNMENT TOOLS most useful assortment #1 \$1.49
- 4 - TV ALIGNMENT TOOLS For Color TV #2 \$1.79
- 8 - TV COLOR ALIGNMENT TOOLS Most popular type \$1
- 5 - 9 VOLT MOTORS Excellent for hobbyist \$1
- 200' #24 SOLID PUSH BACK WIRE Yellow or Black excellent buy \$1.98
- UNIVERSAL TV ANTENNA Back of set mounting, 5 section rods \$1
- 2 - ELECTROLYTIC CONDENSERS 200/304 mfd - 350V \$1
- 8-TRACK TAPE PLAYBACK DECK Compact design fits anywhere \$27.50
- 3-ELECTROLYTIC CONDENSERS 100 mfd-100 V, 50 mfd-75 V \$1
- 2-ELECTROLYTIC CONDENSERS C.D. 500 mfd-200 volts \$1
- 2-ELECTROLYTIC CONDENSERS UNECAP #1 200/1000 Mfd. .50 Volt \$1
- 2-SPRAGUE ELEC. CONDENSERS 30/30V4 Mfd. -475 V \$1
- COLOR CONVERGENCE ASSEMBLY Uni-versal type-good for most sets \$2.49
- COLOR-TV RECTIFIER - Used in most color sets-6500 kv 3 for \$1.95
- 10 - STANDARD TRANSISTORS NPN PNP 2N404, 2N414, etc \$1
- UTAH 8" - HEAVY DUTY 10 OZ. SPEAKER Ceramic Type - 8 Ohm \$3.95
- ENCLOSURE WITH 8" SPEAKER Excellent value, regularly \$14.95 \$5.95

- 8 - MINIATURE ELECTROLYTIC CAPACITORS 5MFD-150 V \$1
- SHURE M44 SERIES DIAMOND NEEDLE exact Replacement \$4.69
- \$20 - SHURE M7D DIAMOND NEEDLE exact replacement \$3
- MATCHED PAIRS TRANSISTORS NPN & PNP (2N4252-2N2904) (2N2222-2N2907) Each set \$1
- KNOB SPECIAL**
- 100 - ASSORTED RADIO KNOBS All standard types \$20 value \$1
- 50 - TV KNOBS - POPULAR TYPES Mostly Selector & Fine Tuning \$1
- 20 - VERTICAL LINEARITY KNOBS Long Shank . . . Front mount . . . assortment \$1
- 20 - VERTICAL LINEARITY KNOBS . . . Side mount . . . Standard sizes \$1
- 25-KNURLED SHAFT KNOBS Hard to get . . . Best selection \$1
- 25 - CLOCK & RADIO KNOBS most popular types \$1
- ANY 6 KITS FOR \$5
- TRANSISTOR RADIO *asst type* good, bad, broken, as-is, potluck \$1.50
- TAPE RECORDER-assorted types good, bad, broken, as-is, potluck \$4
- 300 - ASST. 1/2 W RESISTORS Top Brand, Short Leads, Excellent Selection \$1
- 100 - ASST 1/2 WATT RESISTORS stand, choice ohmages, some in 5% \$1
- 100-ASST 1/2 WATT RESISTORS stand, choice ohmages, some in 5% \$1
- 70 - ASST 1 WATT RESISTORS stand, choice ohmages, some in 5% \$1
- 15 - ASST 1/2 WATT RESISTORS stand, choice ohmages, some in 5% \$1
- 50 - PRECISION RESISTORS asst. list-price \$50 less 98% \$1
- 20 - ASSORTED WIREWOUND RESISTORS, 5, 10, 20 watt \$1
- 10-ASSORTED SLIDE SWITCHES SPST, SPDT, DPDT, etc. SOCKETS Wired leads, for all color TV's \$1
- 3 - RCA 110° CRT SOCKETS Wired leads, for all TV'S \$1
- 25 - SYLVANIA HEAT SINKS For Transistors \$1
- 20 - ASSORTED TV COILS I.F., VIDEO, sound, ratio, etc \$1
- 50 - ASSORTED PEAKING COILS All popular sizes \$1
- 8SR - UA25 STEREO CHANGER most popular replacement \$17.50
- BASE & COVER FOR BSR CHANGER walnut finish, \$7.75
- DELUXE STEEL CABINET 16 drawers, for parts & hardware \$6.95
- SONOTONE CARTRIDGE NO 3T-S \$5
- 32' - TEST PROD WIRE DELUXE QUALITY, red & black \$1
- SOLID STATE UHF CONVERTER 30 Channels 14-83, easy to install \$17.95
- VARCSD STEREO CARTRIDGE-CN-72 With mounting bracket, flipover needle \$2.95
- 20 - PILOT LIGHT SOCKETS bayonet type, wired \$1
- 100' - FINEST NYLON DIAL CORB best size, .028 gauge \$1
- ELECTROSTATIC TWEETER SPEAKER for FM, HI-FI, etc \$1
- 15 - MINIATURE 456KC IF TRANSFORMERS PC 1/4" X 1/4" - good value \$1
- BURGLAR DOOR ALARM WITH CHAIN sets off loud alarm . . . easy to install \$3.49
- 1 - ELECTROLYTIC CONDENSERS 200 mfd - 200V \$1
- 1 - ELECTROLYTIC CONDENSERS 1500 mfd - 35V \$1
- 1 - 5" SPEAKER with output trans former \$1.39
- WELLS GARDNER TV TUNER 25A1283 (6LJ8 - 6 HA 5 tubes) \$7.95
- MERCURY TUBE TESTER MODEL 990A Compact, latest model \$39.95
- MIDLAND STEREO AMPLIFIER Model 28-002, 12 Watt, solid state \$36.50
- MIDLAND STEREO AMPLIFIER Model 26-003, 25 Watt, Solid State \$55.00
- STEREO CAR SPEAKER SET Deluxe Ser-vice Mount \$6.50
- RCA 2 SPEAKER AM-FM CHASSIS Deluxe front panel, good for wall mount \$20.00

## SARKES TARZIAN TUNER 41mc



Latest Compact Model good for all 41 mc TV's.  
**BRAND NEW**

Best TUNER "SARKES TARZIAN" ever made—last word for stability, definition & smoothness of operation. An opportunity—to improve and bring your TV Receiver up-to-date.  
**\$7.95**  
COMPLETE with Tubes

- ALL NEW TV TUNER Standard makes-less tubes \$1
- WESTINGHOUSE FM TUNER (12DT8 Tube) \$2.99
- WESTINGHOUSE FM TUNER #476-V, 015D01 Transistor \$3.99
- 300 - ASSORTED HEX NUTS 2/56, 4/40, 5/40, 6/32, 8/32 \$1
- 250 - ASST. SOLDERING LUGS best types and sizes \$1
- 250 - ASST. WOOD SCREWS finest popular selection \$1
- 250 - ASST. SELF TAPPING SCREWS #6, #8, etc. \$1
- 150 - ASST. 8/32 SCREWS and 150 6/32 HEX NUTS \$1

## TEST EQUIPMENT SPECIAL DISCOUNT PRICES

**BK EICO Leader**  
SENCORE

IMMEDIATE DELIVERY . . . Scientific light packing for safe delivery at minimum cost.  
HANDY WAY TO ORDER . . . Send check or money order, add extra for shipping. Lists of new offers will be returned in your order.

Please specify refund on shipping overpayment desired:  CHECK  POSTAGE STAMPS  MERCHANDISE (our choice) with advantage to customer

**BROOKS RADIO & TV CORP., 487 Columbus Ave., New York, N. Y. 10024** 212-874 5600 TELEPHONE

Circle 80 on reader service card

# NEW

## from endeco



### The Pencil Soldering Iron with Operating Light, 2 Heats and On/Off Switch



**\$10.95**  
NET

Model 540S  
Soldering Iron  
Length 8 1/2"  
Weight 2 oz.

- Light shows when it's on
- 2 heats—20w and 40w—for any job
- Ironclad tips for longer life
- Cool, unbreakable polycarbonate handle
- Burn-resistant neoprene cord
- Converts to a desoldering iron with low cost attachment

### The Pencil Desoldering Iron with Operating Light, and On/Idle/Off Switch



**\$15.95**  
NET

Model 510  
Desoldering Iron | Length 8 1/2"  
Weight 3 1/2 oz.

- Light shows when it's on
- Operates at 40w; idles at 20w for longer tip life
- 6 tip sizes available to handle any job
- Cool, unbreakable polycarbonate handle
- Burn-resistant neoprene cord
- Exclusive new bracket insures alignment, prevents damage

#### New kits also available!

- Soldering Kits • Desoldering Kits
  - Soldering/Desoldering Kits
- See your distributor or write ...



5127 EAST 65TH ST.  
INDIANAPOLIS,  
INDIANA 46220  
PHONE 317/251-1231

enterprise  
development  
corporation

Circle 81 on reader service card

## SPEED TROUBLESHOOTING

(continued from page 49)

then localize to isolate the little block. It will not take long to find the one defective component, even among thousands.

The component isolation, once a defective stage has been found, is not usually quite as difficult as finding the defective stage was in a complex piece of equipment. Even though a circuit may have one of a great many functions, it will have a certain number of characteristics that are common to all circuit functions.

Any stage (there will always be exceptions to prove the rule) will have at least one active component (a tube or transistor) and several passive components (resistors, capacitors, diodes, inductors, etc.) It has a steady state condition and an operating, or dynamic, condition.

Most defective components can be found while a circuit is operating in the steady-state mode. Voltmeter checks on the elements of the active device will usually provide enough information to pinpoint the problem. More often than not the active device is defective in a nonoperating stage. Capacitors, either shorted, leaky, or open, are next on the list of likely failures. Leaky or shorted capacitors will usually upset the circuit's steady-state (dc) operation, but open capacitors will usually have to be found with signals applied.

When measurements are made in either tube or transistor circuitry, the proper test equipment is a must. The loading effect of a piece of test equipment not only introduces measurement error, but may upset circuit bias values enough to cause a stage to cease to operate. That does not help when you are trying to troubleshoot. Inputs to stages are usually much more susceptible to this type of effect than outputs, but know what your test equipment does to a circuit before deciding that the circuit is defective.

Fig. 3 shows the simple tube and transistor circuits which form the basis for a great many functioning blocks in any equipment. The charts beside each circuit show the component most likely to be defective for a given set of readings. Remember that the chart is not ironclad and that there are always variables in a circuit that may not be readily apparent.

Now that you are an expert at logical troubleshooting, and can isolate the defective stage in almost anything, we have a quiz (Fig. 4) for you.

The concluding article next month will have the answers to this month's quiz and a three-part test to enable you to sharpen your troubleshooting skill—down to the component. R-E

SPECIAL OF THE MONTH MEMORIES				
I	1101	256 Bit RAM MOS	\$2.45	Ea.
E	8223	Field Programmable Rom	\$5.95	Ea.
U	7400	7401 7402 7403 7404 7405	\$ .20	Ea.
	7408	7410 7420 7430 7440 7460	.20	
	74L00	.40 74L71	.50	Ea. 7491 \$1.05 Ea.
	74L02	.40 74L72	.50	7492 .85
	74L04	.40 74L73	.75	7495 .85
	74L20	.40 74L74	.75	74123 .99
	74L30	.40 7474	.30	74154 1.75
	7413	.95 7475	.69	74160 1.65
	7441	1.10 7476	.45	74161 1.65
	7442	1.10 7483	1.20	74165 1.65
	7443	1.10 7485	1.20	74181 4.50
	7446	1.40 7486	.45	74192 1.65
	7447	.95 7489	3.25	74193 1.65
	7448	1.25 7490	.69	

#### LINEAR SPECIALS

LM300	Positive Volt Reg.	Ea. \$ .95
LM301	Hi Performance Amp	Ea. .45
LM302	Voltage Follower	Ea. .95
LM308	Micro Power Op. Amp.	Ea. 1.50
LM309H (T05)	5 Volt 200Ma V Reg	.95
LM309K (T03)	5 Volt 1 Amp Reg	Ea. 1.95
LM311 (T05)	Comparator	Ea. 1.50
LM320 (T03)	-5.2V Neg. Reg.	Ea. 3.95
LM320 (T03)	-15V Neg. Reg.	Ea. 3.95
LM380 (Dip)	2 Watt Audio Amp.	Ea. 1.45
NE565	Phase Lock Loop	Ea. 2.95
NE566	Function Generator	Ea. 2.95
NE567	Tone Decoder	Ea. 2.95
707	Op Amp. \$ .35 Ea. or 10 for	3.00
723	Volt Reg. .95 Ea. or 5 for	4.00
741	Freq. Comp. .45 Ea. or 10 for	4.00
747	Dual 741 .95 Ea. or 5 for	4.00

#### EXTRA SPECIAL

5001 LSI Calculator Chip with complete info Each \$7.95

#### LED SPECIALS

Man III	Type Readouts	Ea. 2.95
Man IV	Type 2/10 character	Ea. 3.25
MV50	Type .29 height	Ea. or 4/ 1.00
MV5040	Type large Visable Red	.40 Ea. or 3/ 1.00

Min. Order \$4.00 Prepaid in U.S.  
Orders filled within 3 days after receipt  
Note: add .50 per spec sheet for item priced at less than \$1.00 each.

### INTERNATIONAL ELECTRONICS UNLIMITED

P.O. Box 2238  
Walnut Creek, Calif. 94595

Circle 82 on reader service card

## Digital Multimeter



YOUR digital multimeter is HERE! The functions you need most — at the right price — with no sacrifice in quality.

- \* Autopolarity
- \* 100% Overranging
- \* Large 0.55" Digits
- \* Dual Slope Conversion
- \* LSI & CMOS Circuitry

**\$127**

#### Model 3000 Specifications

Voltage (4 ranges):  
DC 1 mv to 1 Kv  
AC 1 mv to 1 Kv  
50 Hz to 20 KHz  
Resistance (6 ranges):  
1 Ω to 10 meg  
Accuracy:  
0.5% ± 1 digit except  
1.5% AC and 10 meg Ω  
ranges.

115/230 VAC 50/60 Hz

We accept orders on MASTERCARD and BANKAMERICARD. Include all RAISED information on your card.

LINEAR DIGITAL SYSTEMS corp.  
P.O. BOX 954 GLENWOOD SPRINGS, COLORADO 81601  
303-945-6122

Circle 83 on reader service card



# equipment report

## RCA 5MS440 Mini-State TV Antenna System

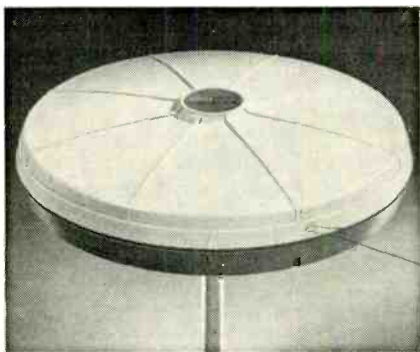

Circle 97 on reader service card

AT FIRST GLANCE YOU MAY THINK that you're seeing a flying saucer hovering over the roof tops, but it's really a new amplified miniature outdoor TV antenna. The 21-inch diameter weatherproof plastic case encloses a vhf travelling-wave antenna and its low-noise electronic solid-state amplifier, a multi-element uhf antenna and a compact, yet efficient rotator.

Having other small antennas before (see **Radio-Electronics**, January 1971, page 26) we set this one up at a test site some 20 miles from the TV transmitters in a densely-populated suburb of New York City. We put the antenna on the roof of a two-story house, connected it to a convenient color set and checked the reception. All local channels—2, 4, 5, 7, 9, 11, 13, 31, and 47—appeared on the screen sharp and clear. There was no discernible snow and ghosts could be eliminated by using the rotator.

As a result of our tests we conclude that this antenna works. While it is a more expensive replacement than a conventional roof antenna, it is the best alternative in locations where you are unable to use or mount a conventional antenna.

Let's look inside the case. As you can see from the photograph the vhf antenna is formed around a foamed plastic form. The ends of the antenna are terminated with a 360-ohm resistor. This antenna delivers a broad forward lobe and a sharply curtailed reception

pattern from the rear. As a result it is possible to effectively eliminate ghost sources that a dipole cannot tune out.

Connected to the vhf antenna is a

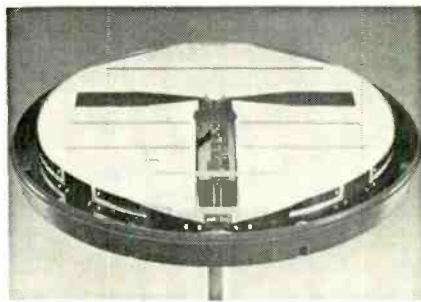

transistor preamplifier with built-in interference filters. The preamp is used only for the vhf antenna. It is powered through the antenna lead-in.

Atop the same plastic form you can see the multistage uhf antenna.

The entire vhf/uhf antenna array is mounted on a circular platform that can be rotated through a full 360°. The entire assembly, antenna and rotator, is housed inside a weatherproof plastic case that is a only 21 inches in diameter, 7 inches high and weighs less than 6 pounds.

Possible antenna mounting locations for the Mini-State antenna are numberless. They include alongside a chimney, on the side of a house, outside an apartment window, under the eaves, in the attic, or in a closet.

The antenna system comes with a separate power supply and uhf/vhf transformer band separator connected behind the set.

A hand-held remote control with 8 feet of connecting cable plugs into the power supply provides remote control of the rotator. An 18-foot optional extension is available.

The antenna comes with a set of snap-on legs for closet or attic mounting and a special clamp is included for installation on a standard mast.

To sum up, the Mini-State is an outdoor antenna that can also be effectively used indoors. It is designed for use where a conventional rooftop antenna cannot be used and a top-of-the-set antenna does not deliver satisfactory performance. **R-E**

## Reduce Car Maintenance Increase Engine Performance.

Put a Mark Ten Capacitive  
Discharge Ignition (CDI)  
System On Your Car.

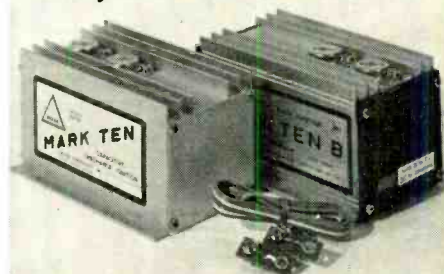

Even Detroit finally recognizes that electronic ignition systems dramatically increase engine performance. Chrysler is now putting them on their new models. The Mark Ten CDI, the original electronic ignition system, has been giving increased performance with lower maintenance to hundreds of thousands of satisfied customers for over eight years. Install a Mark Ten CDI on your car, boat or truck and eliminate 3 out of 4 tune-ups. Increase gasoline mileage up to 20%. Enjoy improved engine performance. Or put a Mark Ten B on your car. It was especially designed for engines with smog control devices. By reducing combustion contaminants, the Mark Ten B restores power losses caused by these devices. Equipped with a convenient switch for instant return to standard ignition, the Mark Ten B is applicable to ANY 12 volt negative ground engine. Both systems install in 10 minutes with no rewiring. Order a Mark Ten or Mark Ten B CDI today.

Mark Ten (Assembled) \$44.95 ppd.

Mark Ten (DeltaKit) \$29.95 ppd.

(Kit available in 12 volt only,  
positive or negative ground.)

Mark Ten B \$59.95 ppd.

(12 volt negative ground only)

Superior Products at Sensible Prices  
Mfg. in U.S.A.



Dept. RE  
**DELTA PRODUCTS, INC.**

P.O. Box 1147 / Grand Junction, Colo. 81501  
(303) 242-9000

Please send me free literature.

Enclosed is \$\_\_\_\_\_  Ship ppd.  Ship C.O.D.

Please send:

\_\_\_ Mark Ten B @ \$59.95 ppd.

\_\_\_ Standard Mark Ten (Assembled)  
@ \$44.95 ppd.

\_\_\_ 6 Volt: Neg. Ground Only

\_\_\_ 12 Volt: Specify

\_\_\_ Positive Ground \_\_\_ Negative Ground

\_\_\_ Standard Mark Ten (DeltaKit®) @

\$29.95 ppd.

(12 Volt Positive Or Negative Ground Only)

Car Year \_\_\_\_\_ Make \_\_\_\_\_

Name \_\_\_\_\_

Address \_\_\_\_\_

City / State \_\_\_\_\_ Zip \_\_\_\_\_

Circle 84 on reader service card

# RANGE 73

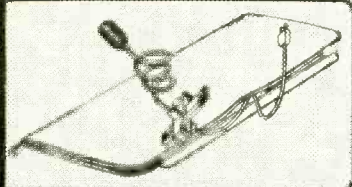

Optional "Portfollo style" carrier. Besides carrying Range 73 parts or tools, uniquely unfolds flat to four times its own size (from 6"x16" to 24"x16") and converts into a pad protector for TV cabinet top when on service calls. — Net \$4.95

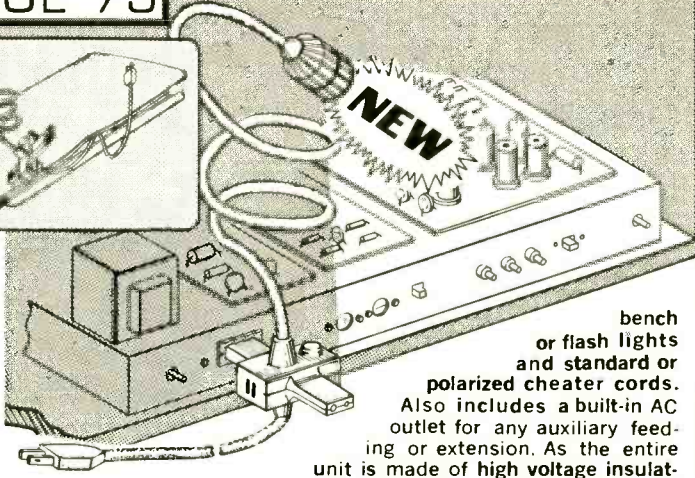

A useful unit for field or bench servicing. Includes a powerful and flexible spotlight mounted on a rigid Poly Sources Body, with Standard and polarized interlocks. When plugged into a TV or any other chassis it provides AC power to them and automatically supports itself, allowing illumination to any part of the chassis being repaired. It eliminates

bench or flash lights and standard or polarized cheater cords. Also includes a built-in AC outlet for any auxiliary feeding or extension. As the entire unit is made of high voltage insulating materials, it allows close-ups of "hot" areas of a TV chassis. When not plugged into a chassis it can be used conveniently by placing in any position or twisted, looped, hung or inserted in almost any place by the special head, neck or body. Its compactness and safety designs allow seeing and inspecting among transistorized and IC components, or even "X Raying" Solid State Printed Circuit Boards. Price — \$9.95 Net

Spotlight ext. to 21 in. • Head dia. 1.4 in. • Bulb: 115V (SP)  
• Power cord: 7 ft. • Weight: 7 oz. • Color: black.

Please mail check or money order "RANGE 73" — Net \$9.95. Optional carrier Net \$4.95. (Add \$1.00 for shipping) (Calif. resident 5% tax)  
OR: Mail Only \$5.95 with order, balance plus shipping on C.O.D.

Made in USA under National and International PATENT RIGHTS EXCLUSIVELY FOR:

**MICHELIN INTERNATIONAL**  
P.O. BOX 6743, Los Angeles, California 90022

Circle 85 on reader service card

# try this

## MAKE YOUR OWN COILED CABLE

You can make your own coiled wire. Simply run the wires through some shrinkable tubing, along with .010-.015 inch spring-steel wire. Wrap it on a wooden dowel of the diameter

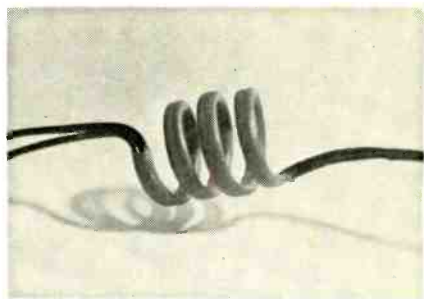

desired and place it over a source of heat such as a heat gun, bathroom heater, gas burner, etc. Tighten the wrap as the tubing shrinks. Allow the tubing to cool thoroughly before removing from the dowel.—A. E. Plavcan

## SOLDERING GUN DEMAGNETIZER

You've probably noticed the annoying habit your soldering gun has of picking up ferrous objects that you're attempting to solder. By increasing the 1/2 turn coil to 2 1/2 turns you can accentuate this effect and use it to demagnetize small tools. The gun should be slowly withdrawn while switched on, of course, as with a bulk

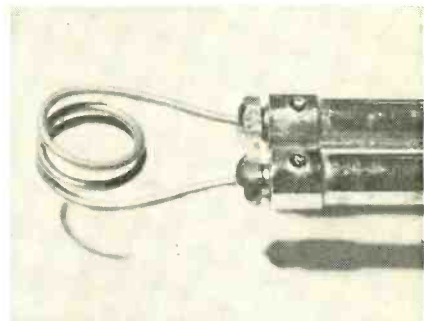

tape eraser.

Pick the heaviest solid copper wire you have to approximate the resistance of a regular tip.

On the other hand, if you want to magnetize, say a screwdriver, you'll have to play roulette with the power line. Switch the gun on and off with the screwdriver in the coil until you get acceptable polarity and strength.—R. G. Cooper

R-E

For  
faster  
service

USE  
ZIP  
CODE

on  
all  
mail

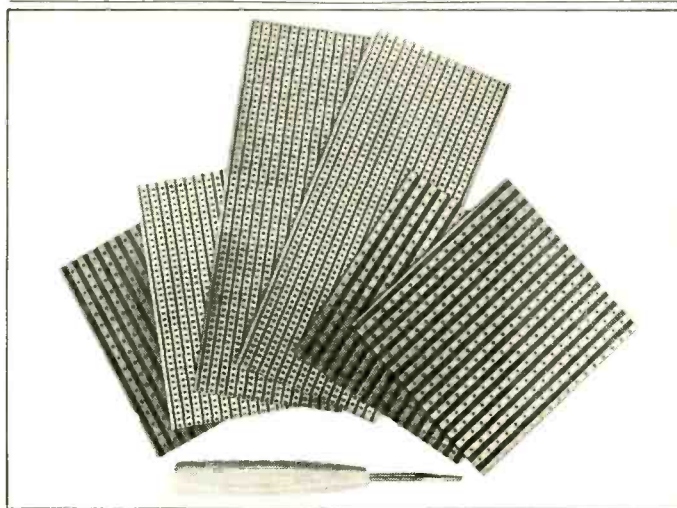

## THE VERO BK-6 KIT LETS YOU BUILD ANY CIRCUIT IN 3 STEPS

Here, in kit form is the fastest, simplest method of circuit building. Veroboard eliminates the need for etching, wires or terminals — you can now build any circuit in 3 easy steps. The BK-6 Veroboard kit contains six assorted veroboards, a spot face cutter and instruction sheet. Try it and you'll never want to go back to the old method again.

\$5<sup>95</sup>

SEND CHECK OR MONEY ORDER  
N.Y. RESIDENTS ADD SALES TAX



**VERO ELECTRONICS, INC.**  
171 BRIDGE ROAD, HAUPPAUGE, N.Y. 11787

Circle 86 on reader service card

# circuits

## BRIDGED-T TRAP

How many times has reception of a weak TV station been ruined by spill-over from a strong adjacent-channel station? Here in New York City, many people try to get channel 3 in Connecticut for blacked-out games. After installing one (or more) channel-3 Yagis, they discover that channel 3 is useless because of the poor adjacent-channel rejection of their TV set.

The textbook solution to this is a  $\lambda/4$  stub cut to trap out the offending carrier (adjacent sound and video do the most damage). But in practice this offers less than 20 dB rejection—not enough for really strong interference. Good traps are available, but are expensive since they are designed for CATV head-ends.

An alternative is the bridged-T L-C filter. Easily homemade, it will provide 50+ dB rejection and a very narrow notch bandwidth. This version is designed for 75-

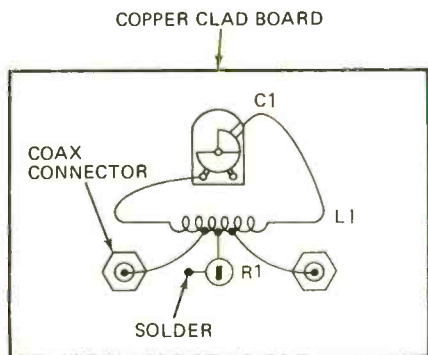
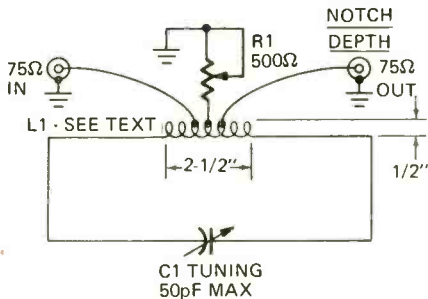

ohm coax, and will tune from 50 to 110 MHz. This includes the 6-meter ham band, channels 2-6 TV and the FM band. The trap should be built on a small piece of copper-clad board. Notice *both* capacitor terminals are *above* ground. An insulated rotor type should be used. The Hammarlund MAPC-50 or equal is ideal. The coil is 9 turns of No. 18 copper wire wound with an inside diameter of  $\frac{1}{2}$  inch. Turns are spaced to occupy  $2\frac{1}{2}$  inch. It is tapped in the exact center, one turn before, and one after. This is to match the coax into the trap properly. Chassis mounting F-type connectors are used for convenient connection into your antenna lead. To tune up, vary C1 to reduce the QRM. Peak the effect with the NOTCH DEPTH control, a 500-ohm miniature trimmer. Repeat these steps. For less than \$5.00 and an hour of work you can now enjoy clear reception. Good dx'ing!—*Jerry Pulice, WB2CPA* R-E

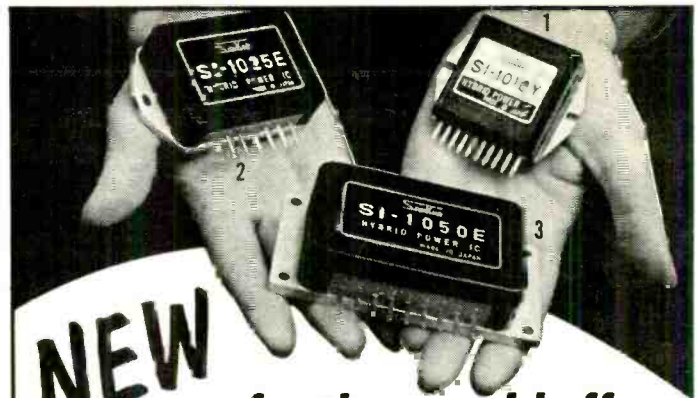

## NEW ...for the sound buff HYBRID POWER AMPLIFIERS

With the addition of a few off-the-shelf components, you can easily build your own quality amplifier for record player, tape deck, tuner, P.A. (musical instruments) or intercom system.

USED BY LEADING MANUFACTURERS • 2 YEAR WARRANTY

AVAILABLE IN 3 MODELS:		CHARACTERISTICS:
Power	RMS IHF	• Harmonic Distortion < .05%
1. SI-1010Y	10W 25W	• Bandwidth 20 Hz — 100K Hz
2. SI-1025E	25W 65W	• Flat response within 1/2ct3
3. SI-1050E	50W 120W	• Input sensitivity 500 mV

Contact your local electronic component distributor!

**AIRPAX**™ INTERNATIONAL DIVISION  
P.O. Box 8488  
Ft. Lauderdale, Fla. 33310

Circle 87 on reader service card

## EIGHT INSTRUMENTS IN ONE

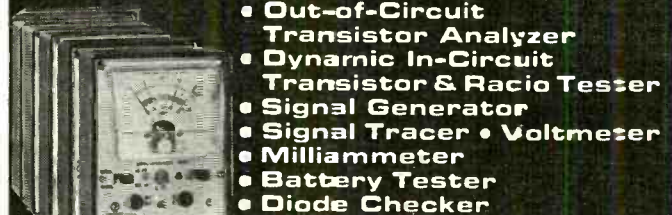

- Out-of-Circuit Transistor Analyzer
- Dynamic In-Circuit Transistor & Ratio Tester
- Signal Generator
- Signal Tracer • Voltmeter
- Milliammeter
- Battery Tester
- Diode Checker

### Transistor Analyzer Model 212

Factory Wired & Tested—\$23.50  
Easy-to-Assemble Kit—\$15.50

YOU DON'T NEED A BENCH FULL OF EQUIPMENT TO TEST TRANSISTOR RADIOS! All the facilities you need to check the transistors themselves — and the radios or other circuits in which they are used — have been ingeniously engineered into the compact, 6-inch high case of the Model 212. It's the transistor radio troubleshooter with all the features found only in more expensive units. Find defective transistors and circuit troubles speedily with a single, streamlined instrument instead of an elaborate hook-up.

#### Features:

Checks all transistor types — high or low power. Checks DC current gain (beta) to 200 in 3 ranges. Checks leakage. Universal test socket accepts different base configurations. Identifies unknown transistors as NPN or PNP.

Dynamic test for all transistors as signal amplifiers (oscillator check), in or out of circuit. Develops test signal for AF, IF, or RF circuits. Signal traces all circuits. Checks condition of diodes. Measures battery or other transistor-circuit power-supply voltages on 12-volt scale. No external power source needed. Measures circuit drain or other DC currents to 80 milliamperes. Supplied with three external leads for in-circuit testing and a pair of test leads for measuring voltage and current. Comes complete with instruction manual and transistor listing.

EMC, 625 Broadway, New York 12, N.Y.

Send me FREE catalog of the complete value-packed EMC line, and name of local distributor.

NAME \_\_\_\_\_ RE-6

ADDRESS \_\_\_\_\_

CITY \_\_\_\_\_ ZONE \_\_\_\_\_ STATE \_\_\_\_\_

## EMC

ELECTRONIC MEASUREMENTS CORP.  
625 Broadway, New York, N.Y. 10012

# market center

**MAN3M**  
 \* 0.127" HIGH LED 7-SEGMENT  
 \* DISPLAYS ALL NUMBERS AND NINE LETTERS  
 \* COMPACT SPACING - 5 PER INCH  
 \* BRIGHT RED 400FT-L AT 10 MA PER SEGMENT  
 EACH ..... \$3.00  
 TEN OR MORE FOR .. 2.50

**LED's**  
 MV-50 RED EMITTING 10-70MA @2V ..... \$0.39  
 MV-5020 RED LED ..... \$0.45  
 MV-108 VISIBLE RED 5-70MA @2V ..... \$0.45

**ACA 2010**  
 NUMITRON DIGITAL DISPLAY TUBE, INCANDESCENT FIVE VOLT SEVEN SEGMENT  
 \* .6" HIGH NUMERAL VISIBLE FROM 30 FEET  
 \* STANDARD NINE PIN BASE (SOLDERABLE)  
 \* LEFT HAND DECIMAL POINT  
 \$4.00 EACH

**CT5005**  
 A SINGLE MOS CHIP WITH ALL THE LOGIC NECESSARY FOR A - TWELVE DIGIT - FOUR FUNCTION CALCULATOR WITH AN EXTRA STORAGE REGISTER FOR CONSTANT OR MEMORY APPLICATION  
 \* 28 LEAD DIL PACKAGE  
 \* CAPABILITIES (+, -, x, /)  
 \* CHAIN CALCULATIONS  
 \* TRUE CREDIT BALANCE SIGN DISPLAY  
 \* AUTOMATIC KEYBOARD DEBOUNCE  
 \* SINGLE VOLTAGE SUPPLY IS POSSIBLE  
 COMPLETE WITH DATA ..... \$12.95  
 DATA ONLY ..... 1.00 (REFUNDABLE WITH PURCHASE OF CHIP)

**SINGLE CHIP 40 PIN**  
 \* ADD, SUBTRACT, MULTIPLY, AND DIVIDE  
 \* 12 DIGIT DISPLAY AND CALCULATE  
 \* CHAIN CALCULATIONS  
 \* TRUE CREDIT BALANCE SIGN OUTPUT  
 \* AUTOMATIC OVERFLOW INDICATION  
 \* FIXED DECIMAL POINT AT 0, 2, 3, OR 4  
 \* LEADING ZERO SUPPRESSION  
 DATA ONLY ..... 1.00 (REFUNDABLE WITH PURCHASE OF CHIP)  
 COMPLETE WITH DATA ..... \$ 9.95

**3 CHIP SET**  
 \* EIGHT DIGIT  
 \* FLOATING DECIMAL  
 \* LEFT HAND ENTRY  
 \* WILL +, -, x, /  
 \* OVERFLOW SIGNALS  
 COMPLETE WITH DATA ..... \$ 8.95  
 DATA ONLY ..... 1.00 (REFUNDABLE WITH PURCHASE OF CHIP)

**NATIONAL/MOS**  
 DYNAMIC SHIFT REGISTERS TO-5  
 MMS02 DUAL 50 BIT 1.25  
 MMS06 DUAL 100 BIT 1.75  
 MMS06b DUAL 100 BIT 1.50  
 MMS0L3 1024 BIT 2.25  
 MMS01b 512 DIL 1.50  
 STATIC SHIFT REGISTERS  
 MMS04 DUAL 16 BIT 1.50  
 MMS05 DUAL 32 BIT 1.75  
 MMS0 DUAL DIFFERENTIAL ANALOG SWITCH 2.50

ALL IC'S-NEW AND FULLY TESTED-LEADS PLATED WITH GOLD OR SOLDER. ORDERS FOR \$5.00 OR MORE ARE SHIPPED PREPAID. SMALLER ORDERS - ADD \$36. CALIFORNIA RESIDENTS ADD SALES TAX. IC'S SHIPPED WITHIN 24 HOURS  
**BABYLON ELECTRONICS** P.O. Box J CARMICHAEL, CA (916) 966-2111

**7400dip**

7400	.35
7400U TTL	.50
7401	.35
7401L	.50
7402	.35
7403	.35
7404	.35
7404H	.50
7405	.35
7405S	.50
74121	1.60
7413	1.15
7410	.25
7420	.35
74L20	.50
74M20	.50
74H22	.50
7430	.35
74L30	.50
7440	.35
74H40	.50
7441	1.60
7442	1.30
7446	1.75
7447	1.75
7448	1.15
7450	.35
7451	.35
74H51	.50
7453	.35
74H53	.50
7454	.35
74L54	.50
7460	.35
74L73	.30
7472	.50
74L72	.60
7473	.65
74L73	.90
7474	.65
74L74	.90
7476	.70
7480	.65
7483	1.30
7486	.80
7489	3.50
7490	1.50
7491	1.15
7492	1.15
7493	1.15
7495	1.25
74L95	2.00
74L07	.70
74L53	2.00
74L23	2.00
74193	1.50
74195	1.30

**CMOS**  
 CD4001 .75  
 CD4002 .75  
 CD4012 .75  
 CD4023 .75

**LINEARS**  
 LM100 1.00  
 LM309H 1.00  
 LM309K 2.00  
 NE5556 1.00  
 NE5558 1.00  
 747 1.00  
 709 .45  
 730 .50  
 711 .40  
 723 1.00

**LINEAR SPECIAL**  
 TEN 741 FULLY COMPENSATED OP AMPS WITH DATA SHEETS  
 8-PIN DIP ONLY  
 TEN FOR \$2.75 EACH .35

**T.I.**  
 H38 PHOTO DIODE \$1.50

**ZENER DIODES**  
 2N4651 3.4V  
 1N4735 6.2V  
 1N4740 10.0V  
 EACH .50

**SEND FOR FREE FLYER!!**

## INVENTIONS & PATENTS

**CASH-ROYALTIES** for patented, unpatented inventions. **GLOBAL MARKETING SERVICE**, 2420-AF 77th, Oakland, Calif. 94605

## WANTED

**QUICK cash** . . . for electronic equipment, components, unused tubes. Send list now! **BARRY**, 512 Broadway, New York, N.Y. 10012, 212 Walker 5-7000

## ELECTRONICS ENGINEERING & INSTRUCTION

**SHORTCUTS** to success! Highly effective, profitable short courses. (75 choices). Study at home. Diploma awarded. Our 27th year. Free literature. **CIEE-E**, Box 10634, Jackson, Miss. 39209

**LOGIC newsletter**, design and construction, sample copy \$1.00. **LOGIC NEWSLETTER**, Box 252, Waldwick, N.J. 07463

**TV TUNER repairs**-Complete course details, 12 repair tricks. Many plans. Two lessons, all for \$1. Refundable. **FRANK BOECK**, Box 3236 (Enterprise), Redding, Calif. 96001

## REBUILD YOUR OWN PICTURE TUBES?

With Lakeside Industries precision equipment, you can rebuild any picture tube!  
 For complete details, send name, address, zip code to:  
**LAKESIDE INDUSTRIES**  
 3520 W. Fullerton Ave.  
 Chicago, Ill. 60647  
 Phone: 312-342-3399



## AN/GRR-5 RECEIVER

1.5 to 18 MHz in 4 Bands. AM, CW and MCW, continuous tuning & 10 pre-set frequency, 200 KHZ crystal calibrator, 4" P.M. speaker, 12 tubes, with power supply for 115 V. 50/60 cyc., 8, 12, or 24 V. DC—Also dry cells 90 & 1.5 VDC. Size, 13 1/2 x 8 1/2 x 12 1/2". Shpg. Wt., 75 lbs. USED, repairable...\$49.50  
 CHECKED, repairable...\$59.50  
 Power Plug ..... \$2.00  
 Manual ..... \$7.50

**R-392 RECEIVER**—500 KHZ to 32 MHz. 32 Bands. 25 Tubes, 24/28 VDC. Size: 11 1/2 x 14 x 11"; 70 lbs. USED, repairable: \$295 CHECKED \$350. Manual: \$8.50  
 All prices F.O.B., Lima, Ohio - Dept. RE  
**SEND FOR OUR BIG NEW CATALOG!**

**FAIR RADIO SALES**  
 1016 E. EUREKA • Box 1105 • LIMA, OHIO • 45802

**AVIATION electronics technician**—Prepare for exciting career in new field of "Avionics". Train at nation's largest aeronautical school. Indicate if eligible for G. I. Benefits. **SPARTAN AIRSCHOOL**, International Airport, MNW, Tulsa, Okla. 74151

**FREE brochure**. FCC license. Key tests-answers. **ACADEMY OF COMMUNICATIONS TECHNOLOGY**. RE-673, Box 389, Roswell, N.M. 88201

## FOR SALE

**DIGITAL electronics!** Complete schematics, parts lists, theories—Discrete Component Digital Clock, \$3.00—Sound Sensitive Switch, \$1.50. Increase technical competence, hobby skills—Complete course in Digital Electronics is highly effective, \$10.00. Free literature. **DY-NASIGN**, Box 60R2, Wayland, Mass. 01778

**B & K**, Sencore test equipment, discount prices. Free catalog and price sheet. **FORDHAM RADIO**, 558 Morris Avenue, Bronx, N.Y. 10451

**LOGIC Probe** with LED display \$20.00 post-paid U.S. Order from **UTI** POB 252 Waldwick, N.J. 07463

**SEMICONDUCTOR** and parts catalog. **J. & J. ELECTRONICS**, Box 1437, Winnipeg, Manitoba, Canada

## BUILD A "SPACE-AGE" TV CAMERA!

ONLY KNOWN SOLID-STATE CAMERA IN KIT FORM!  
 Also available factory assembled  
 \* Ideal for experimentation, industry, education, etc.  
 \* High quality performance backed by over seven years of job and field testing  
 \* Fully Guaranteed  
 \* Completely self-contained  
 \* Connects to any TV set without modification  
 \* Easy-to-follow assembly manual  
 \* Model XT-1A, Series D complete with vidicon \$149.00 P.P. anywhere in USA & Canada (less vidicon tube \$116.95pp). Many other kits, parts and plans also available.  
 PHONE or WRITE for CATALOG.. DIAL 402-987-3771  
**BOX 453-RE ATV Research DAKOTA CITY, NEBR. 68731**

## HIGHLY PROFITABLE ONE-MAN ELECTRONIC FACTORY

Investment unnecessary, knowledge not required, sales handled by professionals. Ideal home business. Write today for facts! Postcard will do. **Barta-DRD**, Box 248, Walnut Creek, CA 94597.

## F.C.C. EXAM MANUAL

PASS FCC EXAMS! Memorize, study—"1973 Tests-Answers" for FCC First and Second class Radiotelephone licenses. Newly revised multiple-choice questions and diagrams cover all areas tested in FCC exams—plus—"Self-Study Ability Test." \$9.95 postpaid.

**COMMAND PRODUCTIONS** P.O. BOX 26348 - E RADIO ENGINEERING DIVISION • SAN FRANCISCO, CALIF. 94126

# Opto Electronics Sale

LIGHT EMITTING DIODE GaAs INDICATORS

- 1-MV2\*, TO-18, Dome, green, visible 1.19
  - 1-MV4\*, stud, high power, red, 2-watts 3.95
  - 1-MV4H\*, stud, high power, hi-dome, red, 2-watts 3.95
  - 2-MV10\*, TO-18, clear, diffused dome, red 1.00
  - 2-MV50\*, axial leads, micro-mini dome, clear, red 1.00
  - 2-MV5022\*, jumbo red dome, TO-18, visible 1.19
  - 2-MV5020\*, jumbo clear dome, TO-18, visible, red 1.19
  - 2-MV5040\*, 4-LED red array, with 5-lead pak 1.49
  - 2-MV5080\*, TO-18, micro-mini, clear dome, red 1.00
  - 1-MV5222\*, jumbo dome, green, panel snap-in 1.98
  - 1-MV522\*, jumbo dome, GaAsP, panel snap-in 1.98
  - 1-MV9000\*, cartridge panel lamp, sealed, red, clear lens 1.49
  - 1-ME-1\*, infra-red, parabolic lens, pin type 1.19
  - 2-ME-4\*, infra-red, "invisible", TO-18, diff. dome 1.19
  - 2-ME60\*, infra-red, "invisible", axial, micro-mini 1.00
  - 5-LED HOBBY SPECIAL, asst. types, axial, TO-18, etc. 1.00
  - 1-LED MAN-4\*, hobby special, readout, 14-pin 1.49
  - 1-LED MAN-3\*, hobby special, readout, "the claw" 1.19
- \* Monsanto LED equivalents.

## LED MITY DIGIT 'DCM'S'

Will outperform any other DCM on the market today, not gaseous, not incandescent, but a device that will READ almost for life. MAN-4, Monsanto equal.



**Digital Counting Modules by Scientific Devices**  
**9.99**  
 INCLUDES P.C. EDGE CONNECTOR — FREE  
 Kit includes: 3 x 2" printed ckt board, with fingers tool Side-mounting MAN-4 socket, resistors, 7448, 7475, 7490, booklet

## OPTO COUPLER PHOTO DARLINGTON RELAY

\$1.98

MCA-30, 1500 volt isolation. 6-pin mini dip. Replaces all types of relays, etc. 100% of opto applications. Infra-red emitter optically coupled to photo darlington amplifier.

## RCA NUMITRON 7-SEGMENT TUBES

\$1.98

DR2000. Character height 0.8" x .235". 5V @ 24 mils per seg. Fit standard 9-pin tube socket. 0-to-9 numerals. **\$3.99**

## RCA DR2110 NUMITRON TUBES

\$3.99

7-Segment, 10-pins, fits TO5 socket. Character size: 0.40" x .230". 5V @ 24 mils per seg. With left decimal. 0-to-9 **\$3.99**

## LED READOUTS

Only \$3.95

0-9 plus letters  
 Snaps in 14-pin DIP socket. 2.5x3x5 characters. 16WV, 5V, 20-mils per seg. characters. 143/16 Famous MAN-1 type.  Sockets .80 ea.

## MAN-2\* ALPHA NUMERIC

\$12.95

5x7 dot matrix (35 LEDs). 0 to 9 and A to Z. Displays 64 characters ASCII code. Requires 2513 character generator. Each diode 3V @ 40 mils. Snaps in 14-pin dip socket.

## MAN-5\* GREEN

\$8.88

0-9 Numerals, 9 letters, left decimal. Snaps in 14-pin dip socket. Size equal to MAN-1. Compatible with ICs. 3V @ 40 mils per seg. 7-segment.

## MAN-8\* YELLOW

\$12.50

0-9 Numerals, 0 letters, left dec. pin. Snaps in 14-pin dip socket. Size equal to MAN-1. Compatible with TTL ICs. 5V @ 40 mils. 7-segment.

## 6-DIGIT MAN-3A MUX'D PC BOARD

\$2.95

Clock DCMs, VTVM, DVM, calculators, multiplexed.  6 MAN-3's for above board, \$9.50.

## 8 TRANSISTOR AMPLIFIER CHASSIS

Only \$3.95

Same as above, except no AM radio section. Completely wired! With built-in preamp-mike, phono and tape inputs. Color-coded wires with diagram and hookup. Works off 9VDC transistor battery. Excellent fidelity. Shpg. wt. 1-lb.

## AC-DC CHARGER-CONVERTER — Only \$1.98

- Converts above 11-and-6-transistor chassis from 9VDC to 110VAC. Easy to hook in. Use as "NICAD" battery charger too (with instructions). Size: 2"x1 1/4"x1 1/4". 1-lb.
- 5-IN. "HI-FI" PM SPEAKER — Only \$1.98
- 5-ounce ceramic, cylindrical magnet. Twin voice coil. 4 and 8 ohms.
- 50-16,000 cycles. Shpg. wt. 3 lbs.

# AM-FM-Stereo-Mux SOUND CONTROL CENTER

ALL 3 PIECES

Only

**29.95**  
HYBRID

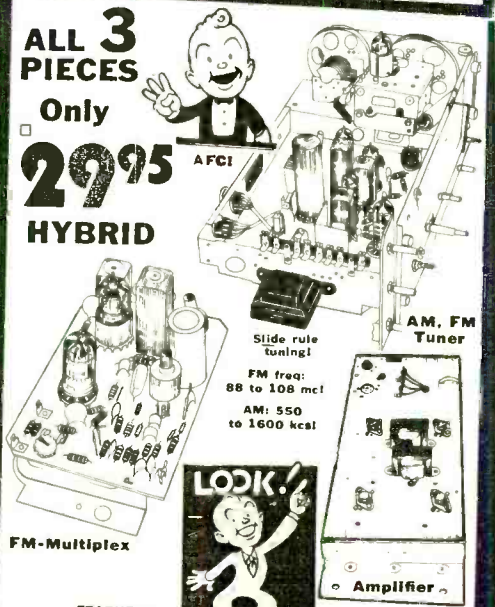

- FEATURES**
- AM, FM, FM-Multiplex stereo phono inputs!
  - Separate Tuner! Amplifier! and Multiplex!
  - FM Tuner has automatic frequency control
  - Hybrid tube, transistor printed circuitry!
  - Separate volume and power controls!
  - Separate bass and treble controls!
  - Remote speaker controls!
  - Connects easily to record changer!
  - Mike, tape, phono inputs!
  - Push-pull power output solid state!

Shpg. wt. for 3-pc. Sound Control Center — 10 lbs.

This is a Poly Pak exclusive. Bought for the economy-minded hi-fies. This unique audio system was designed for \$300 consoles. 35 watts of stereo music power. 3 separate units, each unit professionally designed by U.S.A. engineers. AM-FM tuner, Multiplex, push-pull TO-66 power transistors mounted on chassis. Outputs connect to any good speaker system. Voice coils of 8 to 16 ohms. Unique switch on panel connects external stereo speakers to other parts of rooms, home or office. Concentric volume controls for perfect stereo balance. Has built-in preamplifier, built-in AM antenna. 13"x6"x8"

**TUNER — 13" x 6" x 8"**  
 Tuner uses 17C9 for FM r-f amplifier and converter, 12BA6 for 1st FM i-f amp and AM i-f amp, 12BA6 for 2nd FM i-f amp and AM detector, 12BE6 AM converter, 12AX7 multi-preamp. Separate speaker arrangements for hi-fi and TV. Built-in AFC. Comes complete with 8-pg. 8 1/2"x11" factory booklet, check-full of diagrams, printed circuit layouts of all parts, etc. All parts are easily identified. Power consumption 115 VAC 60 cy. Complete with all interconnecting cables. Wide frequency response. Includes printed front panel template. WHERE CAN YOU GET SO MUCH AM! FM! STEREO! FOR SO LITTLE MONEY?

**MULTIPLY — 4" x 6" x 3"**  
 Multiplex uses 12AT7 amp-doubler, 12AX7 38 kc output amp, with availability of "STEREO STATION INDICATING" lamp.

**POWER AMPLIFIER CHASSIS — 12" x 6" x 2"**  
 All solid state devices, using a pair of driver transistors to push-pull TO-66 "Sound Control Center" power.

## Potter & Brumfield KAP RELAYS

- Your choice 3 for \$7.50 **\$2.98**
- 115 VAC 3PDT \$2.98
  - 12 VDC 3PDT 2.98
- Excellent for "HAM" use as antenna switching, latching, transmit, receive, etc., and 100% of commercial or industrial uses. Includes plastic dust-cover with diagram and hookup info. 11-pin plug-in base. Contacts movable gold flashed silver, stationary overlay, with silver cadmium oxide movables. All contacts 10 amp 3PDT. Coil data: 115VAC 2250 ohms, 17.5 ma, 12 VDC 21 mils 188 ohms. Size: 2 1/4" x 1 5/16". Wt. 4 ozs. Center pin missing. Comar Mix. type equal too.

STUD 'TRIACS'	
PRV	25 amp
50	\$ .65
100	\$ .85
200	\$ 1.25
300	\$ 1.45
400	\$ 1.85
500	\$ 2.25
600	\$ 2.65

LOWEST PRICES EPOXY SILICON RECTIFIERS			
PIV	2Amp	2Amp	3Amp
	\$ .05	\$ .05	\$ .08
50	\$ .06	\$ .06	\$ .12
200	\$ .07	\$ .07	\$ .15
400	\$ .09	\$ .09	\$ .22
600	\$ .12	\$ .12	\$ .28
800	\$ .15	\$ .15	\$ .35
1000	\$ .18	\$ .18	\$ .49

\*microminiature

## NEW! 8-Digit MUX (Multiplex) BURROUGHS 8-DIGIT "UNIVERSAL" NEON READOUTS

PC Board Included! **Only \$19.95** WORTH \$50.00

- Designed for use with LSI, digital clocks, calculators, frequency counters, DVM's, & precision chronometers, tool
- Eight individual Burroughs B5750's Nixie tubes mounted on a universal 4 1/2"x1 1/2" MUX board with pin outs for digit drivers & segment.

Use all 8 readouts or any number of readouts from 1 to 8 SIMPLY, EASILY. Electrical characteristics: 170 VDC, 2 decimal points, 2 anode pins. We include schematics & instructions. • Characters 9/16" high

POWER TRANSFORMER FOR ABOVE 110 to 170 VAC with 6.3V tap on secondary for TTL's **Only \$1.95**

## LED 7-SEGMENT READOUTS

0-9 plus letters, for SN-74 IC. Snaps in 14-pin DIP socket. 3 x 5/8 x 5/8. 5V 10ma, with decimal point. Like MAN-1  Socket for above, 50c

## LED READOUTS

This display is excellent for small portable electronics, such as DVM's, calculators, etc. Equivalent to Monsanto MAN 3A. Operates from 5V, 20 milliamperes, with 47 ohm dropping resistor.

## LED COUNTING SYSTEM

Includes SN7490, decade counter, SN7475 latch, SN7411 BCD decoder driver, 0-to-9 Nixie tube, instructions.

## PHILCO 11 TRANSISTOR AM RADIO CHASSIS

- Use as:
- Mike amplifier
  - Phono amplifier
  - Tape amplifier
  - Covers 55 Kcs to 1500 Kcs Broadcast band
- Only \$5.95**

One of the most versatile AM Radio and multi-purpose amplifiers we have seen at Poly Pak's famous "Economy" price. Measures only 4 1/2" x 3" x 2 1/2" high. With tuning capacitor, IF circuit, loopstick, aut. volume control with switch, AC and phono-mike jacks. Separate switch for changing from AM radio to amplifier. Uses either 110V plug-in adapter (not with unit) and a 9-volt battery power. Exceptional sensitivity and power. Feeds into 16 ohm speaker. Complete with spec sheets, diagrams, and hookup ideas.

## ALLEN BRADLEY 'TRANSISTOR' POTS

Type F. Any 4 Screwwrivers adjust. **for \$1**

Ohms	7.5K
75	10.0K
200	20.0K
250	25.0K
500	50.0K
750	75.0K
1.0K	100K
2.0K	250K
2.5K	2 Meg
5.0K	5 Meg

## ALLEN BRADLEY'S 'MICRO-POTS'

Type B. 1 1/2" dia. x 1 1/2" high. Mounts 1 1/2" hole with shaft in or out. **2 for \$1**

Ohms	2.5K
75	5.0K
100	7.5K
250	10.0K
500	25.0K
750	50.0K
1.0K	100K
2.0K	250K
2.5K	5 Meg

## RADIATION SURVEY INSTRUMENT

**9.95**

Victoren 710B, measures Gamma radiation from 0.1-50 roentgens/hr. This surplus C-D meter is new, guaranteed and comes with a complete manual of instructions, theory of operation, circuitry, detailed parts list. The 20 ma meter is calibrated in roentgens per hour, indicating the presence of gamma radiation. Three multiplier scales (Victoreen 100,000 meg; 10,000 meg; 1,000 meg decade) matched within ±2% Wt. 3 lbs; size 5x4x8 1/2".

## EPOXY FULL WAVE SILICON BRIDGE RECTIFIERS

PIV 2 Amp 6 Amp

100	\$ .69	\$ .88
100	\$ .75	\$ .99
200	\$ .95	\$ 1.25
400	\$ 1.19	\$ 1.50
600	\$ 1.35	\$ 1.75
800	\$ 1.59	\$ 2.00
1000	\$ 1.79	\$ 2.25

Code: 2 amp TO-5 case  
 6 Amp 1/2 x 1/2 x 3/16 sq

156 CATALOG on Fiber Optics, 'ICs', Semi's. Parts **POLY PAKS** P.O. BOX 942R, LYNNFIELD, MASS. 01940

Terms: add postage **Rated: no. 30**  
 Phone Order: Wakefield, Mass. (617) 215-1829  
 Retail: 16-18 Del Carmine St., Wakefield, Mass. (off Water Street) C.O.D.'S MAY BE PHONED!

**MAGIC "SOUND TRIGGER" \$1.98**

Unique Scientific Device. "hand claps", sensitizes crystal mike amplifier, triggers SCR. Needs only 3 to 4 in dc. Use as burglar alarm, intrusion device. Use with photo cell, triggers SCR's, relays, LED's. Even fiber optic light pipe may be used. With hand booklet.



**COMPUTER KEYBOARD W/ENCODER \$35**

Another shipment just received. Alpha-numeric keyboard excellent condition. Once again we expect an early sellout. Price of \$35 includes prepaid shipment in the US and shipment made within 24 hours of receipt of order.

**GIANT B-7971 NIXIES (2)** with 2 sockets and driver board containing hi voltage transistors. Complete plug-in board as removed from operational equipment. Schematics included. Unbelievable but true . . . just \$2.50 for the complete package.

#725-10 \$2.50

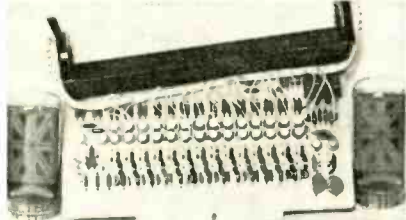

**15¢ IC BONANZA**

Brand new DTL dual inline (DIP) package, factory marked ceramic type. The price is too good to be true. Fully guaranteed and with specs.

930 Dual 4 input NAND gate similar to	7420
931 Clocked flip flop	74110
932 Dual 4 input Expand Buff	7440
933 Dual 4 Input expander	7460
936 Hex Inverter	7405
945 JK Flip Flop	74110
946 Quad 2 input gate	7400
962 Triple 3 input gate	7410

Please add postage for above.

**JOHN MESHNA JR.**  
PO Box 62, E. LYNN, MASS. 01904

Circle 93 on reader service card

**SYLVANIA** black light bulbs 4T5 \$3.00 or 4/\$10.00 ppd. S.A.S.E. for list of surplus and test equipment. **PENINSULAR ELECTRONICS**, 5625 Balfrey Drive, West Palm Beach, Fla. 33406

**MANUALS** for Govt. surplus radios, test sets, scopes. List 50¢. **BOOKS**, 7218 Roanne Drive, Washington, D.C. 20021

**GUARANTEED** metal detectors. Catalog. **DETECTOR**, Room 276-T, 102 W. Arrellaga, Santa Barbara, Calif. 93101

**BARGAINS:** Surplus electronics, free catalog. **ATLANTIS-RE**, Box 12654, Tucson, Ariz. 85711

**OLD** books relating to radio, electronics, photography, law, medicine, text books, novels, and early literature. (Send \$1.00 for list.) **MRS. REX STEPHENS**, 1401 Clay St., Henderson, Ky. 42420

**POLICE** receiver scrambler decoders—Free catalog. **KRYSTAL KITS**, 2202 S. E. 14, Bentonville, Ark. 72712

**CANADIAN'S** free catalog LED's, I.C.'s, transistors, SCR's, diodes, parts. **CORONET ELECTRONICS**, 720 Notre Dame St. W., Montreal, Canada

**BEAUTIFUL** catalog. Free! Professional Line of Guaranteed Metal Detectors. Find Coins, Jewelry, Relics. **FISHER**, Room 627-Q, Box 490, Belmont, Calif. 94002

**SUPREME** sixteen different Radio-Television Diagram manuals, \$40.00 value, only \$14.95 **SUPREME PUBLICATIONS**, 1760 Balsam, Highland Park, Ill. 60035

**FREE** catalog lists resistors, tubes, transistors, rectifiers, condensers, tools, tuners, etc. etc. **HYTRON HUDSON**, Dept. RE 2201 Bergentine Ave., Union City, N.J. 07087

**CANADIAN** surplus catalog \$1.00. **ETCO ELECTRONICS**, 464B McGill, Montreal, Canada

**EXPERIMENTERS** only use my used parts. Save money. Capacitors, resistors, transistors IC's. List 25¢. **TED HOLDER**, 502 Pacific Drive, Belton, Mo. 64012

**1973** hobby electronics directory. Parts, plans, kits surplus, and much more. \$1.50. **NEWCAL**, Box 323-C, El Segundo, Calif. 90245

**FREE** bargain catalog. Transistors, computer boards, diodes, thermocouples, parts. **CHANEY'S**, Box 15431, Lakewood, Colo 80215

**WIRE** wrapping tool \$1.00, DIP wrap panel \$5.00. **XYCON**, Box 9341, Phoenix, Ariz. 85020

## Technical Excellence in Electronics.

On our small, friendly campus the emphasis is on Living as well as Learning. Extra-curricular social activities, student clubs, a student operated radio station, student government, new dormitory and a full sports program help provide a world of your own in which to prepare for tomorrow. Associate Degree in Engineering Electronics. B.S. obtainable. G.I. approved.



**VALPARAISO TECHNICAL INSTITUTE**  
Dept. C, Yellowstone Trail, Valparaiso, Indiana 46383

### TUBES

**RADIO & TV** tubes 36¢ each. One year guaranteed. Plus many unusual electronic bargains. Free catalog. **CORNELL**, 4217-E University, San Diego, Calif. 92105

**SAVE** money on parts and transmitting-receiving tubes, foreign-domestic. Send 25¢ for Giant Catalog. Refunded first order. **UNITED RADIO COMPANY**, 56-R Ferry Street, Newark, N.J. 07105

**RECEIVING & industrial** tubes, transistors. All brands—biggest discounts. Technicians, hobbyists, experimenters—request free giant catalog and save! **ZALYTRON**, 469 Jericho Turnpike, Mineola, N.Y. 11501

### BUSINESS OPPORTUNITIES

**START** small, highly profitable electronic production in your basement. Investment, knowledge unnecessary. Postcard brings facts. **BARTA-REI**, Box 248, Walnut Creek, Calif. 94597

**C & J ENTERPRISES** presents opportunities to double your income on a part-time basis. **BONUSES: \$500-\$35000**, 441 Barchester, Westland, Mich. 48185

**TECHNICIANS** desperately needed, Employers Directory \$2. **CALEIS**, Box 514, Agnew, Calif. 95054

### PLANS & KITS

**DIGITAL** alarm clock kit, contains Mostek MK5017PAA MOS/LSI DIP, 4 Digivac .57 inch readouts, PC board, and instructions. Send \$29.95. **DIGI-TEL ELECTRONICS**, Box 6585, Toledo, Ohio 43612

**BUILD** your own telephone answering service. Detailed plans \$3.90 **TONASCOPE-C** 400 Third Ave., Satellite Beach, Fla. 32937

**CLASSIFIED COMMERCIAL RATE** (for firms or individuals offering commercial products or services). \$1.00 per word . . . minimum 10 words.

**NONCOMMERCIAL RATE** (for individuals who want to buy or sell personal items) 70¢ per word . . . no minimum.

**FIRST WORD** and **NAME** set in bold caps at no extra charge. Additional bold face at 10¢ per word. Payment must accompany all ads except those placed by accredited advertising agencies. 10% discount on 12 consecutive insertions, if paid in advance. Misleading or objectionable ads not accepted. Copy for August issue must reach us before June 1.

## CLASSIFIED ADVERTISING ORDER FORM

1	2	3	4	5
6	7	8	9	10
11	12	13	14	15
16	17	18	19	20
21	22	23	24	25
26	27	28	29	30
31	32	33	34	35

No. of Words { @ .70 Non-Commercial Rates } = \$  
 { @ \$1.00 Commercial Rate } = \$  
 No. of Words in bold face @ .10 = \$

Total Enclosed \$ \$

Insert \_\_\_\_\_ time(s)

Starting with \_\_\_\_\_ issue

Payment must accompany order unless placed through accredited advertising agency 28

NAME \_\_\_\_\_

ADDRESS \_\_\_\_\_

CITY \_\_\_\_\_ STATE \_\_\_\_\_ ZIP \_\_\_\_\_

SIGNATURE \_\_\_\_\_

MAIL TO: RADIO-ELECTRONICS, CLASSIFIED AD DEPT., 200 PARK AVE. SOUTH, NEW YORK, N.Y. 10003

**NEW PURCHASE! NEW LOW PRICE!**  
**"CALCULATOR CHIP" SALE!**

**12-DIGIT "CALCULATOR ON A CHIP" WAS \$12.95**

Similar to Mostek 5001. Outperforms Texas 4-digit TMS102. 40-pin DIP. Adds, multiplies, subtracts, and divides. Use with 7-segment readouts, Nixies, and LEDs. We include schematics, instructions to build calculator.  
 NOW **\$6.95**  
 □ CT5005 — Same as above with MEMORY — \$12.88



**NATIONAL EQUALS ON "DIGITAL CLOCK ON A CHIP"**

Any "Chip" **\$12.88**

Mfrs #	Description	Sale
5311	28-pin ceramic, any readout, 6-digits: A-B-D	\$12.88
5312	24-pin, ceramic, any readout, 4-digits: C-D	\$12.88
5313	28-pin, ceramic, any readout, 6-digits: A-B	\$12.88
5314	24-pin, plastic, LED and incandescent readouts, 6-digits: A-B	\$12.88

**\* Compare and Save!  
 \* Money Back Guarantee!  
 \* With Spec Sheet!**

**GENERAL TELEPHONE DATA ENTRY KEYBOARD**

Used in calculators, touch-tone, encoding, programming devices. 10 PUSH BUTTONS (0 to 9) & 2 uncommitted. All switches have 2 separate poles & 6 separate buses — totaling 6 buses & 24 poles. Any combination of which can be used! Size: 3x2 1/2 x 1 1/2. Easy for panel mtg. too. **\$8.88**

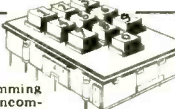

**LOWEST PRICES EVER!**  
**MOS REGISTERS**  
 NATIONAL SIGNETIC

MM500	MM5013	2502	2518
MM502	MM5016	2503	2519
MM505	MM5050	2504	2521
MM506	MM5070	2507	2522
MM506	MM5072	2509	2524
		2514	2527

• SPEC SHEETS! • BRAND NEW!

**WORLD FAMOUS SEMI-KON Dollar Stretchers**

- 5-MOS REGISTERS, 5018-17, mini dips, no-test \$1.
  - 5-MOS REGISTERS, 601-8, etc., TO-5, no-test \$1.
  - 1-2N3055 npn, 100W, 15A, TO-3, transistor \$1.
  - 1-ER900 TRIGGER DIODES for SCRs & Triacs \$1.
  - 2-FET 2N5457 N channel, 6000 ohms, TO-18 plastic \$1.
  - 10-1N914 fast switch diodes, silicon, 4 nanoseconds \$1.
  - 2-6 AMP TRIAC 200 PIV, TO-5 \$1.
  - 40-1TT MICRO MINI RECTIFIERS silicon porcelain to 1KV\* \$1.
  - 30-WORLD'S SMALLEST RECT. & zeners, 1W, assorted volts\* \$1.
  - 4-2N4268 NPN tube driver transistors 100V, npn \$1.
  - 2-PUTS, prox. uni-transistors, similar to GE-D13T \$1.
  - 2-2N2608 P-channel, 2500 uhmo, TO-18 \$1.
  - 2-2N3819, Texas, N channel, 6500 uhmo TO-18 \$1.
  - 3-2N2646 UNIJUNCTIONS, plastic transistors, Texas \$1.
  - 2-2N107, GE, most commonly used pnp, germanium \$1.
  - 50-SILICON, glass rectifiers, computer, axial leads \$1.
  - 50-GERMANIUM, glass rectifiers, 8kOhm, axial leads\* \$1.
  - 5-2N170, GE, RF, germanium, npn, transistors, TO-22 \$1.
  - 10-1-AMF, 1000 V, epoxy, submini, silicon rectifiers \$1.
  - 30-500MW ZENERS, axial, 4, 6, 9, 10, 12V rectifiers \$1.
  - 4-2N3055, HOBBY, 40W npn silicon transistors, TO-3 \$1.
  - 3-3-AMP RECTIFIERS, silicon, epoxy, assorted V. axial \$1.
  - 5-SN7441N, hobby, BCD-to-Nixie driver IC, DIP\* \$1.
  - 10-LINEAR AMPS, 709, 710, 711, 741, TO-5 \$1.
  - 10-709 LINEAR AMPS, 741's too, DIP'S\* \$1.
  - 5-HOBBY MEMORY CELLS, SN7481, up to 16-cell, DIP\* \$1.
  - 2-2N5296 35-WATT NPN PLASTIC TRANSISTORS, for NE-540 \$1.
  - 2-2N2109 40-WATT PNP PLASTIC TRANSISTORS, for NE-540 \$1.
  - 10-RCAs AMPS, TO-5 case \$1.
  - 5-723 VOLTAGE REGULATORS, TO-5 \$1.
  - 4-1000 HFE DARLINGTON Transistors, TO-18 case \$1.
  - 1-2N5036 HI-PWR plastic trans 100 vceo, 7 amp 85 watts \$1.
  - 4-2N5226 HOBE tube driver, plastic powers, PNP \$1.
  - 4-2N6109 HOBBY, 40 watts, plastic powers, PNP \$1.
  - 5-PLASTIC 35W powers, npn, silicon, hobby 2N6121 \$1.
  - 5-PLASTIC 35W powers, pnp, silicon, hobby 2N6124 \$1.
  - 2-MOS FETS, N channel, 10K ohms 3N128, TO-18, RCA \$1.
  - 2-MOS FETS, P channel, 10K ohms 3N129, TO-18, RCA \$1.
  - 2-MOS FETS, DUAL GATE, N chan. 3N140, TO-18, RCA \$1.
  - 4-RCA 2N3600 NPN, UHF transistors, tv-fm, TO-18, 1000mc \$1.
  - 4-PHASE LOCK LOOPS, hobby 665, 660, 661\* \$1.
  - 10-MINI DIPS phase lock loops, 709, 741, 301, 307, hobby\* \$1.
  - 2-VOLTAGE REGULATORS, to 50K, hobby, TO-3 \$1.
  - 1-DARLINGTON AMP, w/gain of 50,000 hfe, TO-18, plastic \$1.
  - 1-300V PLASTIC POWER TAB transistors, 6W \$1.
  - 5-TO-5 Case 536, 540, 566, 567, 741\* \$1.
- \*Untested, guaranteed satisfaction

- 1-PHOTO TRANSISTOR, with darlington amp filter, lens \$1
- 2-PHOTO TRANSISTORS, with darlington amp, 2N5777, GE \$1
- 4-PHOTO CELLS, Clairex, pancake, 38K TO-70 ohms \$1
- 2-SILICON SENSORS, TEXAS, H-88 Matchatich, visible \$1

- SUPER ECONOMY \$1 PARTS "DOLLAR STRETCHERS"**
- 30-POWER RESISTORS, 3-to-25m, square, vitreous, ass. vals. \$1.
  - 10-MICRO REED SWITCHES, 1" long, transistor work \$1.
  - 1-\$25. SURPRISE PAK, resistors, caps, transistors, etc. \$1.
  - 50-TERMINAL STRIPS, 1-to-8 screw & tie lugs \$1.
  - 30-SQUARE DISCS, 85mm, to 0.1mf, space-savers \$1.
  - 75-PRE-FORMED DISCS, condensers, printed circuit \$1.
  - 60-TUBE SOCKETS, receptacles, plugs, audio, etc. \$1.
  - 100-PRE-FORMED RESISTORS, 1/2 watt, printed circuit \$1.
  - 50-COILS & CHOKES, if, rf, ant. peaks, osc, parasitic \$1.
  - 60-PRECISION RESISTORS, 1/8, 1/2, 1 & 2w, 1% ass't. vals. \$1.
  - 60-TUBULAR CONDENSERS, to 50K, to 1kv, mixed too \$1.
  - 30-POLYSTYRENE CONDS. finest caps made, ass't. values \$1.
  - 10-PANEL SWITCHES, 110VAC, micro, rotary, thermal, slide \$1.
  - 10-VOLUME CONTROLS, to 1 meg, duala too, some w/switch \$1.
  - 40-MICRO MINI RESISTORS, 1/4w, 100 ohm to 1 meg, 5% \$1.
  - 40-MICRO MINI-MINI CONDENSERS, to .05mf ceram! \$1.
  - 5-IBM COMPUTER BOARDS, trans, caps, res, coils, etc. \$1.
  - 10-ELECTROLYTIC COND'S, PP's, & tubular, 2 & 3 sect. too \$1.
  - 6-TRIMMER POTS, 100, 500, 2K, 5K, 10K, 25K, 1/4w, snap-in \$1.
  - 4-MICRO POTS w/knob, snap-in, 1/5w, 25k, 50k, 100k, 1 meg \$1.
  - 30-YELLOW-CLARIFIED PLASTIC ASSORTED VALUES & SIZES \$1.
  - 10-POWER TRANSISTOR SOCKETS, for TO-3, ass't. types \$1.
  - 64-PLASTIC TRANSISTORS TO-18, printed circuit \$1.

**Lowest Prices Largest Selection TTL IC's**

Brand New • "DIP" Packages Order by type number! Spec sheets on request "ONLY" Buy 3 or more, 10% discount

Type	Sale	Type	Sale	Type	Sale
SN7400	\$0.30	SN7438	.60	SN7481	1.50
SN7401	.30	SN7440	.30	SN7482	.95
SN7402	.30	SN7441	1.40	SN7483	1.50
SN7403	.30	SN7442	1.25	SN7485	1.41
SN7404	.35	SN7443	.35	SN7486	1.55
SN7405	.32	SN7444	1.35	SN7489	3.75
SN7406	.55	SN7445	1.35	SN7490	1.50
SN7407	.55	SN7446	1.65	SN7491	1.50
SN7408	.55	SN7447	1.65	SN7492	1.10
SN7409	.35	SN7448	1.50	SN7493	1.10
SN7410	.30	SN7450	.35	SN7495	1.10
SN7411	.35	SN7451	.35	SN7496	1.10
SN7413	.95	SN7453	.35	SN7497	1.50
SN7415	.55	SN7454	.50	SN74100	1.49
SN7416	.55	SN7460	.35	SN74104	.55
SN7417	.55	SN7464	.50	SN74105	.55
SN7420	.30	SN7465	.50	SN74107	.60
SN7421	.35	SN7470	.50	SN74108	1.25
SN7422	.35	SN7472	.50	SN74112	1.25
SN7426	.35	SN7474	.65	SN74113	1.25
SN7430	.30	SN7475	1.30	SN74114	1.25
SN7432	.30	SN7476	.75	SN74121	.70
SN7437	.60	SN7478	.95	SN74122	.75
		SN7480	.75	SN74123	1.20
				SN74140	.50
				SN74145	1.40
				SN74151	1.25
				SN74153	1.60
				SN74154	2.10
				SN74155	1.50
				SN74157	1.55
				SN74158	1.95
				SN74160	1.95
				SN74161	1.95
				SN74162	1.95
				SN74163	1.95
				SN74164	3.50
				SN74165	3.50
				SN74180	1.20
				SN74181	4.50
				SN74182	1.20
				SN74184	2.50
				SN74185	2.50
				SN74192	1.95
				SN74193	1.95
				SN74194	1.95
				SN74195	1.35
				SN74198	2.65
				SN74199	2.65
				SN74200	9.99

Designed by our Scientific Device engineers as the most advanced digital timing device in the consumer "time" field. One radio-and-TV station engineer tells us, "Not a change of a second in 3 months." It is so accurate we use it as our standard. KRONOS KR100 Series, in the new sleek all-purpose walnut-and-black modern design cabinet, enhances any office, home, den, etc. It becomes a "visible-action conversation piece" wherever it is placed. Has modern LSI National Clock Chip, and 8-page brochure chock-full with pictorials and easy-to-understand, step-by-step instructions. This kit is COMPLETELY SIMPLIFIED making do-it-yourself easy! Other features include 3 setting controls, 1 hour per second, 1 minute per second, and hold button. Easy-to-change from 12 to 24 hours, 4 to 6 digits, 50 to 60 Hz operation. Your choice of different type readout systems: □ MAN-3 Type LED, □ MAN-1 Type LED (the larger character size), □ 7-Segment Nixie Type Tubes. Kit includes genuine POLAROID filter. Buy 3 — Take 10%  
**WIRED ADD \$19.95**

**KRONOS \$47.**  
 With Cabinet  
**'TIME STANDARD' CHRONOMETER**

□ KR101 7-Segment MAN-3 Type LED, 6 Digits \$47.00  
 □ KR102 7-Segment MAN-1 Type LED, 6 Digits \$69.95  
 □ KR104 7-Segment Nixie Type Tubes \$47.00

Size of cabinet: 6" x 5 1/4" x 6" deep

**DIGITAL CLOCK "CLOSE OUT"** While They Last!

The lowest price digital clock kit (with cabinet) as far as we can see in U.S.A. Scientific Devices' engineering dept. took extra patience in designing to give you the finest digital clock kit using the latest techniques in an easy-to-understand booklet. The cabinet-making section gives it the "interior decorating" touch so that it may fit into any room at home, shop or office. The laminated tapered front cabinet, with gold-line front tapered legs for easy viewing. Large G.E. 7-segment fluorescent "blue-green" polaroid glow for the latest easy-viewing. FEATURES: 6 display tubes, completely etched and thru plated circuit board, all IC's include BIPOLAR outputs for use with timer options, may be wired for 12 or 24 hour display. Indicates HOURS, MINUTES, SECONDS. 116 VAC 60 cy. Gift packed. Wt. 3 lbs.

**\$39.95** **DIGITAL CLOCK KIT**  
 \* Smaller & more compact  
 \* 8" x 5 1/2" x 3" case

**SIGNETIC TTL IC'S** Buy Any 3 — Take 10% Off!

Type	Sale	Type	Sale
8200	1.40	8680	1.50
8210	1.25	8681	1.00
8223	7.25	8820	1.20
8230	1.50	8842	1.25
8250	1.00	8845	1.25
8520	1.50	8880	1.50

**NATIONAL 'OP' AMPS** BUY ANY 3 — TAKE 10%  
 Type Description Price  
 LM-300 Super 723 V. reg. \$1.49  
 LM-301 Hi-performance amp \$1.49  
 LM-302 Voltage follower 1.49  
 LM-304 Neg. V. reg. 1.49  
 LM-305 Pos. V. reg. 1.49  
 LM-307 Super 741 1.50  
 LM-308 Super gain op amp 1.50  
 LM-309H 5V 200 mil V. reg. 1.50  
 LM-309K 5V 1-amp V. reg.\* 2.25  
 LM-320 Comparator 1.50  
 LM-350 1/4-amp V.R.\* 2.95  
 LM-320 Minus 15V 1-amp V.R.\* 2.95  
 LM-370 Dual peripheral driver .59  
 LM-371 AGC squelch op amp 1.49  
 LM-373 R-F, I-F, op amp .69  
 LM-380 AF, FM, SSB, I-F strip 3.75  
 LM-380 2-watt audio amplifier 1.95

\*TO-3 case, \* others TO-5

**LINEAR Op Amps** **FACTORY MARKED** Buy Any 3 PAIRS — Take 10% Discount

Type	Description	Price
531	Hi slow rate op-amp (TO-5)	\$2.50
532	Micro power 741 (TO-5)	2.50
533	Micro power 709 (TO-5)	2.50
536	FET input op amp (TO-5)	3.95
537	Precision 741 (TO-5)	2.50
540	70W pwr driver amp (TO-5)	2.04
550	Precision 723 voltage reg. (DIP)	1.17
555	Timer 2 uSeconds to 1-hr (A)	1.00
556	5 Times faster than 741C	55.88
558	Dual 741 (mini DIP)	3.25
560	Phase lock loops (DIP)	3.25
561	Phase lock loops (OIP)	3.25
562	Phase lock loops (DIP)	3.25
565	Phase lock loops (A)	3.25
566	Function generator (A)	3.25
567	Tone generator (A)	3.25
595	Four quadrant multiplier	3.10
702C	Hi-grain, DC amp (TO-5)	.44
703C	RF-I-F, amp, 14 ckts (TO-5)	1.00
709C	Operational amp (A)	.44
709CV	Op amp (mini DIP)	.49
710C	Differential amp (A)	.44
711C	Dual diff. comp (A)	.44
723C	Voltage regulator (A)	.95
741C	Frequency compensator 709 (A)	1.00
741CV	Freq. comp 709 (Mini DIP)	.49
747C	Dual 741C (A)	1.25
748CV	Freq. adj. 741C (A)	.44
748CV	Freq. adj. 741C (mini DIP)	.49
709-709	Dual 709C (DIP)	1.00
739-739	Dual stereo preamp	1.98
741-741	Dual 741C (A)	1.00
7454D	Dual peripheral driver (DIP)	.69

(A) TO-5 or DIP dual in line pak

**GENERAL ELECTRIC \$2.95 3-WATT AUDIO AMP** 3 FOR \$6.00

Delivers 3 watts continuous, 10 watts peak. Will heat sink with a pair of complementary 3N14's. 9 to 30V supply. High sensitivity, 8 to 16 ohms. For mono and stereo phonos, tape, FM, AM, TV, servo.

**INTEGRATED CIRCUIT SOCKETS** Buy Any 3 — Take 10% Discount!

- 14-Pin, dual in line \$5.45
- 16-Pin, dual in line \$5.50
- TO-8, 8 or 10 pins .29

**WIRE-WRAP 79¢ ea**  
**INTEGRATED CIRCUIT SOCKETS** 3 for \$2.00

**"How's Your MEMORIES For 1973?"**

1101	256 BIT RAM MOS	\$3.50
1103	1024 Bit RAM MOS	5.50
2513	Character Gen. ROM	1.50
2516	Character Gen. ROM	12.50
7459	64 Bit RAM TTL	3.50
8223	Programmable ROM	7.95
MMS260	1024 BIT RAM	6.88

**35 WATT AUDIO AMPLIFIER BASIC** Only \$3.33 2 FOR STEREO

For Class AB use. Basic includes: Signetic 540 30 transistor high power driver TO-5 100W 1G with a pair of complementary 3N14's, 30 watt plastic transistors, i.e. 2N5296 npn and 2N6109 pnp. With schematics, printed circuit and parts board layouts.

**15¢ CATALOG on Fiber Optics, IC's, Semi's, Parts**

**POLY PAKS**  
 P.O. BOX 942R, LYNNFIELD, MASS. 01940

Terms: add postage. Rated: net 30. Phone Orders: Wakefield, Mass. (617) 245-3829. Retail: 16-18 Del Carmine St., Wakefield, Mass. (off Water Street) C.O.D.'S MAY BE PHONED

# ADVERTISING INDEX

**RADIO-ELECTRONICS** does not assume responsibility for any errors which may appear in the Index below.

READER SERVICE CARD NO. PAGE

87	Airpax Electronics	99
	Amperex	76
10	Arrow Fastener Co., Inc.	22
	Bell & Howell Schools	72-75
15	B & K, Division of Dynascan Corp.	34
80	Brooks Radio & TV Corp.	95
2	Castle TV Tuner Service, Inc.	2
17	Channel Master	69
20	Cleveland Institute of Electronics	62-65
	Contemporary Marketing, Inc.	89
	CREI, Division of the McGraw-Hill	
	Continuing Education Co.	28-31
6	Crown International	14
68	Crystek	89
23	Delta Electronics	80
84	Delta Products, Inc.	97
88	Edmund Scientific Co.	106
76	EICO, Electronics Instrument Co.	92
	EMC, Electronic Measurements Corp.	99
62	Electro-Voice, Inc.	86
73	EPD Electronics	91
81	Enterprise Development Corp.	96
12	E.S. Enterprises	26
69	Fordham Radio Supply Co.	89
77	Grantham School of Engineering	93
	GTE Sylvania Electronic Components	
	Heath Co.	24-25
1	ICS School of Electronics	1
64	Indiana Home Study Institute	86
67	International Crystal Mfg. Co.	88
82	International Electronics Unlimited	96
22	Jerrold Electronics	79
71	Judson Research & Mfg. Co.	90
5	LaSalle Extension University	13
9	Lee Electronic Labs	17
83	Linear Digital Systems Corp.	96
3	Mallory Distributor Products Co.	5
85	Michelin International	98
27	Midwest Hi-Fi	82
11	Micro-Instrumentation Telemetry Systems, Inc.	23
63	National Camera Co.	86
	National Radio Institute	8-11
	National Technical Schools	18-21
61	Perma-Power	85
26	PTS Electronics, Inc.	82
21	Radio Shack	77
24	Raytheon Co.	80
	RCA Electronic Components	
	Semi conductors	78
	Test Equipment	94
65	RCA Parts & Accessories	87
90	RCA Parts & Accessories	Cover IV
16	RCA Sales Corp.	68
75	Rye Industries, Inc.	92
70	S & A Electronics	90
25	Sams & Co., Howard W.	81
19	Sansui	71
18	Schober Organ	70
14	Shure Bros.	32-33
89	Southwest Technical Products	Cover III
4	Sprague	7
8	Tab Books	16
72	Telematic	90
78	Tri-Star Corp.	94
7	Tuner Service Corp.	15
74	TV Tech Aids	91
28	University Sound	83
86	Vero Electronics, Inc.	98
13	Winegard	27
66	Workman Electronic Products, Inc.	88
	<b>MARKET CENTER</b>	<b>100-105</b>
	ATV Research Corp.	100
91	Babylon Electronics	100
	Barta	100
	Command Productions	100
	Cornell Electronics	100
96	Digi-Key	105
	Fair Radio Sales	100
	Lakeside Industries	100
93	Meshna Electronics, John Jr.	102
92	Polypaks	101
94	Polypaks	103
95	Solid State Sales	104
	Yeats Appliance Dolly Sales Co.	104
	<b>SCHOOL DIRECTORY</b>	<b>102</b>
	Valparaiso Technical Institute	102

**YEATS dollies**

**Most Versatile Color Television Truck Developed!**

**YEATS PLATFORM DOLLY**

**FREE illustrated brochure**

**YEATS dollies**  
1324 W. FOND DU LAC AVE.  
MILWAUKEE, WIS. 53205

**YEATS Model No. 5 \$76.50**

**PARTS! CORNELL TUBES!**

Send For **FREE** **CORNELL'S** New Color Catalog

**33¢** per tube  
**36¢** per tube

ORDER FREE IF NOT SHIPPED IN 24 HOURS!

48 Pcs. New Items IN LOTS OF 100

**4215 E UNIVERSITY AVE. SAN DIEGO, CALIF. 92105**

**ELECTRONIC organ kits, keyboards and many components.** Independent and divider tone generators. All diode keying. I.C. circuitry. With our kits you can build any tone or size organ desired. 25¢ for catalog. **DEVTRONIX ORGAN PRODUCTS**, Dept. B, 5872 Amapola Dr., San Jose, Calif. 95129

**REGULATED variable DC voltage supply.** 1 Amp output adjustable from 2 to 18 Volts. Less than 30mv variation from no load to full load! Short circuit protected. Kit \$20.95 plus \$1 shipping. Assembled \$26.95 plus \$1 shipping. **Moneyback guarantee.** **L&F ELECTRONICS**, Box 2186, Riverview, Mich. 48192

**DESIGN services:** Need a circuit design? Send \$1.00 for complete schematic and details of amplifier to A/D converter. For quote on P.C. layouts, instrument design, or development, send \$1.00 and specifications for handling. **R. D. 1, Box 136-B, Apollo, Pa. 15613**

(continued on page 105)

<b>8000 series IC's</b>		<b>TRANSISTOR SPECIALS</b>	
8230—1.75	8271—1.95	2N965 PNP 6E TO-18 .15W 7V .1A 300MHZ 40Hte 5/\$1.00	
8233—1.75	8273—1.75	2N1605 NPN 6E TO-5 .15W 24V .1A 14MHZ 125 5/\$1.00	
8234—1.75	8275— .90	2N2360 PNP 6E TO-33 .06W 20V .05A 980 32 \$1.50	
8241—1.75	8280—1.75	2N5324 PNP 6E TO-3 60W 250V 10A 20 35 \$1.50	
8242—1.00	8T13—1.75	2N1015D NPN SI TO-82 150W 200V 7.5A .025 10 \$1.45	
8250—1.95	8T14—1.75	2N2015 NPN SI TO-36 150W 50V 10A .012 26 \$9.00	
8252—1.95	8T22—1.75	2N3584 NPN SI TO-66 35W 250V 2A 10 100 \$1.50	
8262—1.95	8T24—1.75	2N3055 NPN SI TO-3 115W 100V 15A .01 50 \$1.00	
8267—1.75	8T26—1.75	2N3772 NPN SI TO-3 150W 60V 30A .2 30 \$1.25	
8269—1.00	8T80—1.10	2N5296 NPN SI TO-220 36W 40V 4A .8 60 \$5.60	
8270—1.95	8T90—1.10	2N6109 PNP SI TO-220 36W 40V 4A .8 60 \$5.60	
		2N4898 PNP SI TO-66 25W 40V 4A 4 46 \$6.50	
		MJ2251 NPN SI TO-66 10W 225V .5A 10 40 \$7.70	
		2N3638 PNP SI TO-5 .3W 25V .5A 10 67 5/\$1.00	

**PRINTED CIRCUIT BOARD**  
4 1/2"x6 1/2" double sided fiberglass board, 1/16" thick, un-etched \$1.60 ea. 5/\$2.50

**NIXIE TUBES**  
Similar to Raytheon 8754 tubes, with socket & data sheet \$2.25 3/\$6.00

2N3819 FET \$1.50  
TIS43 UJT \$1.50

**VERIPAX PC BOARD**  
This board is a 1/16" single sided paper epoxy board, 4 1/2"x6 1/2" (standard veripax), DRILLED and ETCHED which will hold up to 21 single 14 pin IC's or 8, 16 or LSI DIP IC's with busses for power supply connections. It is also etched for a 22 pin connector. \$4.50

**ER900 TRIGGER DIODES.** These bidirectional trigger diodes are one of the best and cheapest methods to trigger SCR's and triacs .4/\$1.00  
FLV 100 Visible LED .65  
ME-4 IR LED .65  
MRD 14B photo darlington .65  
MV 5026 Vis. LED .65  
MT-2 PHOTO TRAS. .90  
MCT-2 OPTO-ISOL. \$1.49  
MCD-2 OPTO-ISOL. \$1.49  
3/4" reed switch 6/\$1.00  
1N4886 25-40W Power varactor \$4.95

**TRIACS**

PRV	1A	10A	15A	20A*
100	.40	.70	1.00	1.20
200	.70	1.10	1.50	1.60
300	.90	1.35	1.90	2.00
400	1.10	1.60	2.30	2.40
500	1.50	2.00	2.70	2.80

\*Press fit  
Terms: FOB Cambridge, Mass.  
Send check or Money Order. Include Postage. Average Wt. per package 1/4 lb. No. C.O.D.'s. Minimum Order \$3.00

5V 1 Amp regulated power supplies. These units are similar to Analog Devices encapsulated SE 905 power supplies. \$34.95

**MAN-3 LED READOUT \$2.95**

**MAN-4 LED 5 Volt READOUTS \$4.50 3/\$12.00**

8223 field prog. ROM \$8.00  
1101 256 bit RAM \$4.00  
8225 64 bit read-write RAM \$4.95

**Full Wave Bridges**

PRV	2A	6A
200	.95	1.25
400	1.15	1.50
600	1.35	1.75

**DECADE COUNTER KIT**  
CONSISTING OF:  
1—NIXIE TUBE and SOCKET  
1—7490 1—7475 1—7441  
Special priced at \$5.95

**TTL IC SERIES**

7400— .30	7476— .60
7401— .30	7480— .65
7402— .30	7481—1.25
7403— .30	7483—1.25
7404— .35	7486— .60
7405— .35	7490—1.30
7410— .30	7492—1.00
7411— .35	7494—1.20
7420— .30	7495— .90
7430— .30	74107— .90
7440— .30	74123—1.30
7441—1.50	74141—1.35
7442—1.50	74154—1.95
7446—1.50	74161—1.79
7447—1.50	74192—1.75
7448—1.50	74193—1.75
7450— .30	74194—2.35
7460— .30	8570—1.90
7472— .40	8590—1.90
7473—1.00	9309—1.95
7474— .50	9312—1.95
7475—1.00	9322—1.95

14 Pin DIP sockets .50  
16 Pin DIP sockets .60

**PRECISION TRIM POTS**  
500ohm, 10K, 20K, 25K  
50K \$1.75 3/\$2.00

**Silicon Power Rectifiers**

PRV	1A	3A	12A	50A
100	.06	.11	.24	.90
200	.07	.14	.35	1.25
400	.09	.20	.50	1.50
600	.11	.25	.70	1.80
800	.15	.30	.90	2.30
1000	.20	.35	1.10	2.75

**LINEAR CIRCUITS**

PA234 1W audio ampl.	\$1.25
PA264—5 Watt regulator	\$1.25
LM309K 5V 1A regulator	\$2.25
531 High slew oper amp	\$2.50
536 FET input oper amp	\$3.25
537 Precision 741	\$2.50
540 70W Power driver	\$2.04
555 2 us to 1 hour timer	\$1.19
560 phase lock loop	\$3.25
561 phase lock loop	\$3.25
565 phase lock loop	\$3.35
566 Function gen	\$3.25
567 Tone decoder	\$3.25
703 RF—IF amplifier	\$ .80
Dual 709	\$ .95
709C operational Amp	\$ .50
723 Regulator	\$ .75
741 operational Amp	\$ .50
747 Dual 741	\$1.25
TVR 2002 high power	
723	\$1.00
CA3065 FM/TV amp	\$1.35
5558 dual 741	\$ .88
LM 308 oper amp	\$2.95
5556 oper amp	\$ .75
101 oper amp	\$ .75
741 CV oper amp	\$ .55
320 —5V reg.	\$1.75
320 —15V reg.	\$1.75
424 Zero volt switch	\$1.25

**Silicon Control Rectifiers**

PRV	6A	10A	20A	70A
50	.25	.32		
100	.30	.45	1.00	3.50
200	.50	.75	1.25	6.50
300	.60	.90	1.50	
400	.70	1.10	1.75	9.50
500	.80	1.25	2.00	
600	.90	1.40	2.25	11.00

**OLID TATE SALES**

Post Office Box 74D Somerville, Mass. 02143 Tel. (617) 547-4005



# technotes

## SQUELCH ON MONITOR RECEIVER

Squelch in the Knight-Kit 220 and 221-A vhf FM monitor receivers is obtained by increasing the bias to cutoff on the first audio input stage. This lets the interstage coupling capacitor (between the first and second af amplifiers) float at the B-plus level and may make hum in the squelched audio worse than the unsquelched background noise.

I solved this problem by connecting a small neon lamp (1/25 watt, without resistor) from the plate of the

first af amplifier to ground. When the tube is biased to cutoff, the rising plate voltage fires the neon lamp, which then acts as a voltage regulator to prevent the voltage across the capacitor from soaring.

I had to replace the 12AX7 with a 12AT7—at a cost of a slight loss in gain—to bring the plate voltage down low enough on conduction to extinguish the lamp. Changes in plate load resistance and B-plus supply voltages in an effort to still use the 12AX7 gave inferior results.—*H. P. Neylon*

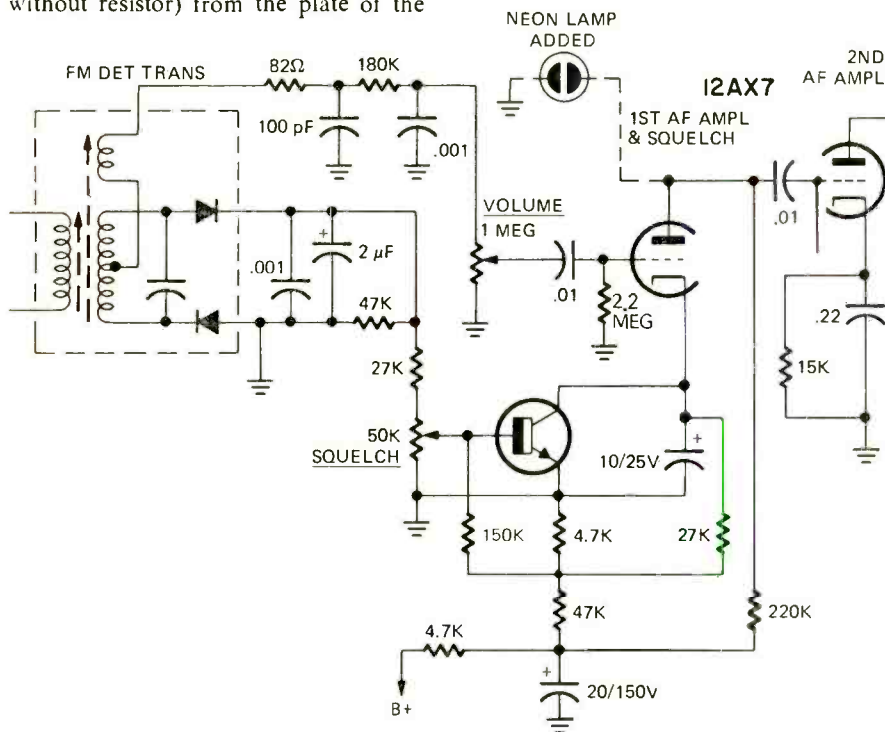

## BLUE DROOP

Blue droop is the inability to converge horizontal blue lines at the edges. In Magnavox color chassis this condition can be corrected by optimizing the value of R816 which is connected in series with the HORIZONTAL BLUE TILT control. In most chassis R816 will be a 10-ohm, 1-watt resistor. In some cases, however, the circuit tolerances are such that the optimum value of R816 for proper correction may be 22 or 33 ohms. If blue droop is noticed on any chassis, you may find that the best value of resistor R816 may be anywhere between 10 ohms and 33 ohms.—*Magnavox Service News Letter*

R-E

**CONVERT** any television to sensitive big-screen oscilloscope. Only minor changes required. No electronic experience necessary. Illustrated plans \$2.00. **RELCO**—A25, Box 10563, Houston, Tex. 77018

**FREE** catalog. Most unusual electronic kits available. Music accessories, Surf, Wind Synthesizers, Wind Chimes, many others. **PAIA ELECTRONICS**, Box B14359, Oklahoma City, Okla. 73114.

## TAPE & RECORDERS

**RENT** 4-track open reel tapes—all major labels—3,000 different—free brochure **STEREOPARTI**, 55 St. James Drive, Santa Rosa, Calif. 95401

# IC PRICES SLASHED

## FACTORY FIRSTS

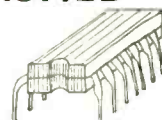

NATIONALLY KNOWN BRANDS SATISFACTION GUARANTEED

DIGITAL TTL			
7400N	32¢	7454N	32¢
7401N	32¢	7472N	39¢
7402N	32¢	7473N	48¢
7403N	32¢	7474N	48¢
7404N	35¢	7475N	72¢
7410N	32¢	7476N	53¢
7420N	32¢	7486N	53¢
7430N	32¢	7490N	72¢
7440N	32¢	7492N	72¢
7441N	\$1.50	7493N	72¢
7442N	\$1.20	7495N	\$1.20
7447N	\$1.15	74107N	54¢
7451N	32¢	74121N	56¢
7453N	32¢		

## LINEAR INTEGRATED CIRCUITS

709C MINIDIP	40¢	10/\$3.50	100/\$29
723C TO-5	90¢	10/\$8.25	100/\$78
741C MINIDIP	50¢	10/\$4.05	100/\$36
748C MINIDIP	55¢	10/\$4.50	100/\$40
558 MINIDIP	88¢	10/\$6.90	100/\$61
LM301 MINIDIP	45¢	10/\$3.70	100/\$31
LM309K TO-3	\$2.50	5/\$11.25	

The above full specification first line devices are also available with "relaxed specs", fully functional at discounts up to 50%. Mail reader service card for flyer.

## GENERAL PURPOSE SILICON TRANSISTORS

2N3638	PNP	20¢	10/\$1.65	100/\$15.00
2N3638A	PNP	22¢	10/\$1.80	100/\$16.50
2N3641	NPN	23¢	10/\$2.00	100/\$17.50
2N3643	NPN	23¢	10/\$2.00	100/\$17.50
2N5133	NPN	15¢	10/\$1.25	100/\$10.00
2N5134	NPN	15¢	10/\$1.25	100/\$10.00
2N5137	NPN	18¢	10/\$1.50	100/\$13.65
2N5138	PNP	15¢	10/\$1.25	100/\$10.00
2N5139	PNP	15¢	10/\$1.25	100/\$10.00
2N3055	NPN	\$1	10/\$9.50	100/\$86.25

## 1 AMP SILICON RECTIFIERS

1N4003	200PIV	12¢	100/\$6	1M/\$45
1N4005	600PIV	10¢	100/\$7	1M/\$55
1N4007	1000PIV	7¢	100/\$9	1M/\$75

## DTL INTEGRATED CIRCUITS DIP PACKAGE

930, 936, 945, 946 and 962 .....Specify number of each type .....20¢ 10/\$1.75 100/\$16.00

## SILICON SIGNAL DIODES

1N4148 (1N914 equiv.) 20/\$1 100/\$4 1M/\$30

## RTL INTEGRATED CIRCUITS TO-5 EPOXY PACKAGE

uL900, uL914 and uL923 .....Specify number of each type .....5/\$1.00 100/\$15.00

## MOLEX IC SOCKET PINS

100/\$1.00 200/\$1.80 300/\$2.60 500/\$4.20 700/\$5.80 1000/\$8.20 ea addn 1000/\$7.50

## READOUT TUBES

5 Volt 7 Segment Readout Tube \$3.75. Counting and Display Kit (Readout Tube +7490+7475+7447) \$5.75, 3 Kits for \$16.50

## 1/4 & 1/2 WATT 10% RESISTORS

1/4 W 5¢ 30/\$1.20, 100/\$3.00, 500/\$13.75 as low as 1.7¢ ea in quantity-see catalog  
1/2 W 4¢ 30/\$0.90, 100/\$2.50, 500/\$11.25 as low as 1¢ ea in quantity-see catalog

COD orders accepted for same day shipment. Call 218 681 6674.

Free Catalog—Large Quantity Discounts—Orders Less Than \$10.00 Add 25¢—Others Postpaid

**DIGI-KEY** PRICE PACESETTER FOR QUALITY IC'S  
BOX 126H THIEF RIVER FALLS, MN56701

# LIVE IN THE WORLD OF TOMORROW...TODAY!

## A BETTER LIFE STARTS HERE

### 3-CHANNEL COLOR ORGAN KIT

Easy to build low-cost kit needs no technical knowledge. Completed unit has 3 bands of audio frequencies to modulate 3 independent strings of colored lamps (i.e. "lows"-reds, "middles"-greens, "highs"-blues. Just connect hi-fi, radio, power lamp etc. & plug ea. lamp string into own channel (max. 300w ea.). Kit features 3 neon indicators, color intensity controls, controlled individ SCR circuits; isolation transformer; custom plastic housing; instr.



Stock No. 41,831EH .....\$15.75 Ppd.



### TERRIFIC BUY IN HE-NE LASERS

Low price on 0.5mW Laser (random mode); 0.9mm beam dia. (at 10M, -16mm) belies its quality. New cold aluminum cathode tube for more life stability (hi beam: 9000-hr tube life under normal cond.) Ready to plug in, turn on. Starts instantly. Safe, easy for holography, interferometry, alignment. Metal case, 2.8 x 3.8 x 10", 110v AC, 633nm wavelength,

small beam divergence.

Stock No. 79,020EH .....\$88.50 Ppd.

0.7mW (SINGLE TEM<sub>00</sub>MODE), 0.8mm BEAM DIA.

Stock No. 79,024EH .....\$99.50 Ppd.

### 130 EXPERIMENTS IN OPTICS . . .

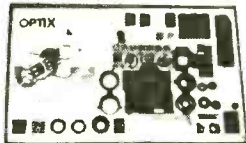

and photography! Optix® Experiments Kit is a complete optical & photography lab for 130 exciting experiments. Lets you recreate the periscope, telescope, microscope, kaleidoscope! . . . Build a 35mm reflex camera with interchangeable lens system! Make, develop photographic film! Enjoy the fun and fascination of having your own optics lab. Fully illustrated 112-pg. manual, 8½"x11", clearly explains usage of this stimulating kit's 114 precision engineered components.

Stock No. 71,646EH .....\$21.00 Ppd.

(And our FREE CATALOG is packed with exciting and unusual ecological & physical science items—plus 4,000 finds for fun, study or profit . . . for every member of the family.)

### NEW! ELECTRONIC DIGITAL COMPUTER KIT

Solve problems, play games, predict weather, even play miniature chess, with this actual working model of giant electronic brains. Amazing new fun way to learn all about computer programming . . . logic, decimal, binary systems, Laws of Sets. Even do your own programming after completing the simplified, 116-page instruction booklet. Circuits are easily changed, readout is from an illuminated control panel. Requires 2 "D" batteries (not incl.)

Stock No. 71,434EH . . .\$31.50 Ppd. (11 x 12½ x 4")



### 140 ELECTRICAL EXPERIMENTS! SEE FEATURE ARTICLE IN THIS ISSUE!

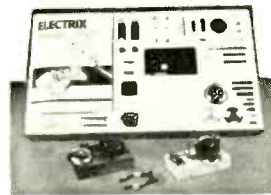

Explore the fun world of electricity, magnetism, telecommunications. Exciting new Electrix<sup>®</sup> Experiment Kit enables you to build a Morse code sender, receiving buzzer & printer; produce electricity with a real generator; assemble a working phone system; build an electric motor; 135 other projects. 11lus. 112-pg. 8½ x 11" manual explains easy use of kit's 135 precision parts. Safety approved. Everything you need except 4 "C" cells.

Stock No. 71,647EH . . . \$17.95 Ppd.

### FEATHERWEIGHT TREASURE FINDER

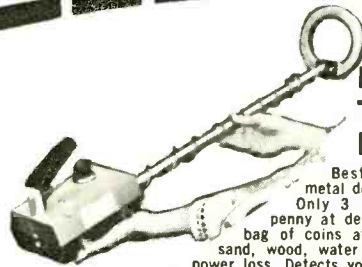

Best, easiest to use solid state metal detector at its price. U. S. made! Only 3 lbs. 6" search head detects penny at depth of 5", silver dollar at 8", bag of coins at 18". Easily works thru dirt, sand, wood, water (30" deep) and rock with no power loss. Detects your "find" sharply with "sound-off" loudspeaker. Comes ready to go. One tuner control; all transistor; adjust. stem; perfect balance. Includes 9v battery, FREE TREASURE GUIDE TO 101 Treasure Sites.

Stock No. 80-175EH .....\$39.95 Ppd.

10—Transistor Treasurer Finder

Stock No. 80,181EH .....\$71.00 Ppd.

### MAIL COUPON FOR GIANT FREE CATALOG!

164 PAGES • MORE THAN 4000 UNUSUAL BARGAINS!

Completely new Catalog. Packed with huge selection of telescopes, microscopes, binoculars, magnets, magnifiers, prisms, photo components, ecology and Unique Lighting items, parts, kits, accessories — many hard-to-get surplus bargains. 100's of charts, illustrations. For hobbyists, experimenters, schools, industry

**EDMUND SCIENTIFIC CO.**

300 Edscorp Building, Barrington, N. J. 08007

Please rush Free Giant Catalog "EH"

Name \_\_\_\_\_

Address \_\_\_\_\_

City \_\_\_\_\_

State \_\_\_\_\_ Zip \_\_\_\_\_

### COMPLETE & MAIL WITH CHECK OR M.O.

**EDMUND SCIENTIFIC CO.**

300 Edscorp Building, Barrington, N.J. 08007

How Many	Stock No.	Description	Price Each	Total

PLEASE SEND  GIANT FREE CATALOG "EH"

MERCHANDISE TOTAL \$

HANDLING CHARGE \$1.00\*

TOTAL \$

\*50¢ ON ORDERS OVER \$5.00

**30 DAY MONEY-BACK GUARANTEE**

YOU MUST BE SATISFIED OR RETURN ANY PURCHASE IN 30 DAYS FOR FULL REFUND

I enclose  check

money order for \$ \_\_\_\_\_

NAME \_\_\_\_\_

ADDRESS \_\_\_\_\_

CITY \_\_\_\_\_ STATE \_\_\_\_\_ ZIP \_\_\_\_\_

Circle 88 on reader service card

# SOUTHWEST TECHNICAL PRODUCTS CORPORATION

219 W. RHAPSODY

SAN ANTONIO, TEXAS 78216

PHONE: 512 DI 4-3140

May 1973

Dear Radio-Electronics Reader,

As promised last month, I am going to let you in on some of our secrets, and explain some of the neat features that you will find in our kits. This month I am going to talk about color organs. In case you don't know it Southwest Technical makes two of the most sophisticated color organs available anywhere. Color organs have gotten a bad name with many people due to the "Mickey Mouse" things that have been sold for color organs. I have seen so called color organs that consisted of a lamp, an SCR and a capacitor.

Southwest Technical Products has two color organs. Both have four channels and both will handle up to 800 Watt loads on each channel. The most unique of the Two is our Psychedelia II, the world's only digital color organ. This circuit actually measures the frequency of the music input to the color organ and then displays the result as a particular color of light. The rate at which measurements are taken is adjustable, so you can have slow changes from one color to another, or you can set it fast enough to get a strobe effect from the lamps. Since the color organ will never sync with the music exactly at the same point from one time to the next the display will be different each time even with the same music. This type color organ does not follow the music in quite the obvious way that the more common filter types do. The display seems more random due to the sampling process used. Input level may be anything from 50 Mw to 50 Watts with no effect on the circuit's operation. The input is transformer isolated so that the Psychedelia II may be safely driven from any speaker terminals. Watching this one go is a real trip. If you are a rock fan, you will probably really dig this kit.

For those who are more at home with Lawrence Welk than the Grand Funk, we have our Psychedelia III. This is a classical filter type color organ circuit that splits the incoming music into four frequency bands and then varies the intensity of the lamps in each channel in proportion to the level of the sound in that channel. Filtering is done with operational amplifier active filter systems. The input system has a compressor amplifier that allows a 40 dB variation in music input level before the color organ display is affected. No jumping up and down to adjust the color organ every time the record changes with this circuit. The lamps are controlled by our exclusive ramp integrator system. This power control system is able to change the power level up to sixty times a second. Thus you never get a lag in color organ response with Psychedelia III. The display lamps themselves are the only things that limit the reaction time of this system. Transformer isolated input for safety.

Both kits are built on 8¼ x 5½ fibreglass circuit boards. As in all of our kits the components are first class new material. You can have either in kit form for \$44.95, or assembled and tested for \$60.00. Your BankAmericard or Master Charge is welcome—just send number and expiration date. If you did not understand half of what you read about our color organs, please buy the assembled unit. Our kits are not designed for beginners. Your gray headed old mother could not put one together. If you don't understand schematics, read color codes and know how to solder please save us both lots of hassle and don't buy a kit from us.

If you would like a copy of our FREE new 1973 catalog listing these and many other unique and interesting kit projects, call, write, or circle our number on the bingo card in the back of the magazine. I will get one to you immediately. See you next month.

Daniel Meyer



SOUTHWEST TECHNICAL PRODUCTS CORPORATION

DEPT. RE-L

219 W. RHAPSODY, SAN ANTONIO, TEXAS 78218

Circle 89 on reader service card

# Announcing the RCA MINI-STATE Antenna System



**The profitable new  
achievement in antenna technology.**

The Mini-State is brand new from RCA. It's the first true miniaturized rotating antenna system on the market. *It works . . . and works well!*

This system is specifically made for your metropolitan and suburban customers who want the quality reception of an outdoor-type antenna, in a beautifully compact unit suitable for homes and apartments.

Measuring just 21" across and 7" high, the Mini-State is completely enclosed in an attractive sturdy plastic case that's weatherproof and resistant to dust and dirt. It weighs just 6 pounds and can be mounted almost anywhere: rooftop, chimney, window, attic and closet.

The RCA Mini-State's uni-directional pattern, VHF slotted ring and multi-element UHF design, combined with its completely integrated solid state circuitry, provides excellent reception on all channels, and helps avoid interference and ghosts.

Mini-State model 5MS440, with built-in rotator, allows your customers to zero-in for best reception on any chan-

nel. Exclusive direction indicator light on the hand held control unit tells them where the antenna is aimed.

The RCA Mini-State rotating antenna system includes: The antenna with built-in amplifier. Built-in rotator and hand held remote control unit. A 120 volt AC power supply. A VHF-UHF antenna matching transformer. An outdoor mast clamp. Legs which can be snapped into place for indoor use.

Although regular coaxial and rotator cable may be used, a unique combined coaxial and rotator cable is available in prefabricated lengths for quick, easy installation. (A fixed non-rotating model 5MS330 is also available.)

Yes, this new RCA Mini-State antenna system can mean maxi-profits for you. See your RCA Parts and Accessories distributor today, or contact RCA Parts and Accessories, P.O. Box 100, Deptford, N.J. 08096. Make sure you're in on the ground floor of this profitable new era in TV antenna systems.

**RCA**

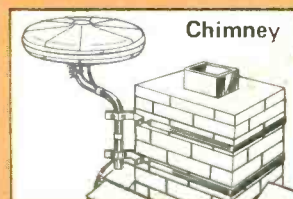
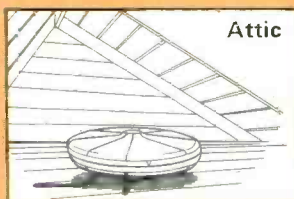
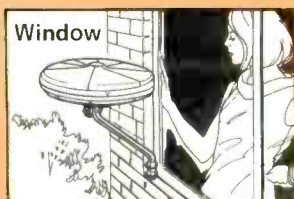

Circle 90 on reader service card